

# **PROJECT INFORMATION DOCUMENT**

Gateway Pacific Terminal

Whatcom County, Washington

## **Pacific International Terminals, Inc.**

1131 SW Klickitat Way

Seattle, Washington 98134

February 28, 2011

Available online at:

[https://secureaccess.wa.gov/ofm/iprmt24/site/alias\\_\\_1357/22894/review\\_documents.aspx](https://secureaccess.wa.gov/ofm/iprmt24/site/alias__1357/22894/review_documents.aspx)



## ACRONYMS AND ABBREVIATIONS

APE	Area of Potential Effect	NAAQS	National Ambient Air Quality Standard
AREMA	American Railway Engineering and Maintenance-of-Way Association	NEPA	National Environmental Policy Act
B&O	Business & Occupation	NHPA	National Historic Preservation Act
BACT	Best available control technology	NO	nitric oxide
bgs	Below ground surface	NO <sub>2</sub>	nitrogen dioxide
BMP	Best management practices	NO <sub>x</sub>	nitrogen oxides
BPA	Bonneville Power Administration	NOAA	National Oceanic and Atmospheric Administration
BTBA	Public Transportation Benefit Area	NPDES	National Pollutant Discharge Elimination System
CAA	Clean Air Act	NRHP	National Register of Historic Places
CEQ	Council on Environmental Quality	NWAA	Northwest Archaeological Associates
CFR	Code of Federal Regulations	NWCAA	Northwest Clean Air Agency
CH <sub>4</sub>	methane	OHWM	Ordinary high water mark
CIF	Cost, insurance, and freight	ORA	Governor's Office of Regulatory Assistance
CO	carbon monoxide	PEC	passive emission control
CO <sub>2</sub>	carbon dioxide	PEM	Palustrine emergent
CO <sub>2e</sub>	carbon dioxide equivalents	PFO	Palustrine forested
CWA	Clean Water Act	PHS	Priority Habitats and Species
DAHP	Department of Archaeology and Historic Preservation	PID	Project Information Document
dB	Decibel	PM	particulate matter
dB <sub>RMS</sub>	Decibel, root mean square	PM <sub>2.5</sub>	particulate matter or particles with diameters less than or equal to about 2.5 micrometers
DPM	diesel particulate matter	PM <sub>10</sub>	particulate matter or particles with diameters less than or equal to about 10 micrometers
DPS	Distinct population segment	ppm	parts per million
dwt	Dead weight tons	PSS	Palustrine scrub-shrub
Ecology	Washington State Department of Ecology	PUD	Public Utility District
EFH	Essential Fish Habitat	RACT	Reasonable Available Control Technology
EIS	Environmental Impact Statement	RCW	Revised Code of Washington
ESA	Endangered Species Act	RHA	Rivers and Harbors Act
ESU	Evolutionary significant unit	RIMS	Regional Input-Output Modeling System
GMD	Glaciomarine drift	RPW	Relatively permanent water
GPS	Global positioning system	SA	Settlement Agreement
HGM	Hydrogeomorphic	SAP	Sampling and Analysis Plan
HII	Heavy Impact Industrial	sec	Seconds
I-5	Interstate 5	SEPA	State Environmental Policy Act
ITE	Institute of Transportation Engineers	SHPO	State Historic Preservation Office
kg	Kilogram	SO <sub>2</sub>	sulfur dioxide
LII	light Impact Industrial	SOK	spawn-on-kelp
LOS	Level of Service	SPCC	Spill prevention, control, and countermeasures
m	meter	SR	State Route
MAP	Multi-agency permitting	SSDP	Shoreline Substantial Development Permit
MDP	Major Development Permit	Terminal	Gateway Pacific Terminal
MHHW	Mean higher high water		
MLLW	Mean lower low water		
MMPA	Marine Mammal Protection Act		
MOA	Memorandum of Agreement		
mph	Miles per hour		
MSA	Magnuson-Stevens Act		
Mtpa	Million metric tons per annum		
N <sub>2</sub> O	nitrous oxide		

TNW	Traditional navigable waterway
TWSC	Two-way stop-controlled
UGA	Urban growth area
USACE	U.S. Army Corps of Engineers
USC	United State Code
USDOT	U.S. Department of Transportation
USFWS	U.S. Fish and Wildlife Service
VAT	Value added taxes
V/C	Volume/capacity
VTA	Vessel Traffic Analysis
WCC	Whatcom County Code
WDFW	Washington Department of Fish and Wildlife
WDNR	Washington Department of Natural Resources
WEC	Washington Environmental Council
WISAARD	Washington Information System for Architectural & Archaeological Records Data
WSDOT	Washington State Department of Transportation
WSHR	Washington State Heritage Register
WTA	Whatcom Transportation Authority
µg	micrograms

## TABLE OF CONTENTS

CHAPTER 1	INTRODUCTION.....	1-1
1.1	PURPOSE OF THE PROJECT INFORMATION DOCUMENT .....	1-1
1.2	PROJECT OVERVIEW AND KEY FEATURES .....	1-5
1.3	PROJECT LOCATION .....	1-9
1.4	PROJECT DEVELOPER AND PROPERTY OWNERSHIP .....	1-10
1.5	CONTENTS OF THE PROJECT INFORMATION DOCUMENT .....	1-13
CHAPTER 2	PROJECT PERMITTING .....	2-1
2.1	PERMITS AND AUTHORIZATIONS .....	2-1
2.1.1	Whatcom County .....	2-1
2.1.2	Federal Permitting .....	2-4
2.1.3	State Approvals and Leases .....	2-5
2.1.4	Environmental Review Under NEPA and SEPA.....	2-5
2.1.5	Process to Coordinate Permitting among Agencies .....	2-6
2.2	TRIBAL CONSULTATION AND COORDINATION.....	2-6
CHAPTER 3	PURPOSE AND NEED .....	3-1
3.1	PURPOSE OF THE PROPOSED ACTION .....	3-1
3.2	PACIFIC INTERNATIONAL TERMINALS, INC.'S, STATEMENT OF NEED.....	3-1
3.2.1	The Need to Ship Bulk Commodities to and from International Markets.....	3-1
3.2.2	The Need for a Multimodal Deep-Water Bulk Marine Terminal in the Puget Sound Region.....	3-2
3.2.3	The Need for Community and Economic Development.....	3-3
3.2.4	The Need for an Appropriate Site .....	3-4
CHAPTER 4	THE PROPOSED ACTION .....	4-1
4.1	PROJECT OVERVIEW .....	4-1
4.2	PROPERTY OWNERSHIP .....	4-1
4.3	THE PROPOSED PROJECT .....	4-2
4.3.1	East Loop .....	4-3
4.3.2	West Loop .....	4-8
4.3.3	Shared Services Area .....	4-21
4.3.4	Wharf and Access Trestle.....	4-21
4.3.5	Rail Access.....	4-31
4.3.6	Stormwater Management Systems .....	4-32
4.3.7	Lighting.....	4-45
4.3.8	Utilities.....	4-45
4.4	PLANNED TERMINAL CONSTRUCTION STAGING .....	4-47
4.4.1	Stage 1 Terminal Construction .....	4-47
4.4.2	Stage 2 Terminal Construction .....	4-48
4.4.3	Operational Phasing .....	4-49
4.5	TERMINAL OPERATION .....	4-50
4.5.1	Employment.....	4-50
4.5.2	Commodities Likely to be Handled.....	4-51
4.5.3	Rail Operations Characteristics.....	4-51
4.5.4	Wharf Operational Characteristics .....	4-53
4.5.5	Dust Control Measures during Operations .....	4-53
4.5.6	Vessel Traffic.....	4-54

4.5.7	Emergency Response .....	4-61
4.5.8	Energy Conservation.....	4-62
4.6	CONSTRUCTION.....	4-62
4.6.1	Terminal Construction Logistics.....	4-63
4.6.2	Wharf and Trestle Construction Logistics .....	4-63
4.6.3	Custer Spur Rail Construction Logistics .....	4-64
4.6.4	Construction Practices .....	4-65
CHAPTER 5	ENVIRONMENTAL RESOURCES AND PROJECT EFFECTS.....	5-1
5.1	EARTH.....	5-2
5.1.1	Affected Environment .....	5-2
5.1.2	Potential Effects on Topography, Soils, and Geology .....	5-9
5.1.3	Proposed Design Features Intended to Reduce Impacts.....	5-11
5.2	UPLAND VEGETATION, WILDLIFE, AND HABITATS .....	5-13
5.2.1	Affected Environment .....	5-13
5.2.2	Potential Effects on Upland Vegetation, Wildlife, and Habitat .....	5-23
5.2.3	Proposed Design Features Intended to Reduce Impacts.....	5-29
5.3	MARINE RESOURCES .....	5-29
5.3.1	Affected Environment .....	5-29
5.3.2	Effects of Construction on Marine Resources.....	5-45
5.3.3	Effects of Operation on Marine Resources .....	5-47
5.3.4	Proposed Design Features Intended to Reduce Impacts.....	5-52
5.4	WETLANDS, STREAMS, AND OTHER DRAINAGES .....	5-58
5.4.1	Affected Environment .....	5-58
5.4.2	Potential Development Effects.....	5-70
5.4.3	Temporary Wetland and Stream Effects.....	5-74
5.4.4	Potential Operational Effects .....	5-75
5.4.5	Proposed Design Features Intended to Reduce Impacts.....	5-75
5.4.6	Proposed Compensation.....	5-81
5.5	ARCHAEOLOGICAL, CULTURAL, AND HISTORIC RESOURCES .....	5-83
5.5.1	Affected Environment .....	5-84
5.5.2	Potential Effects on Archeological, Cultural, and Historic Resources.....	5-90
5.5.3	Proposed Design Features Intended to Reduce Impacts.....	5-90
5.6	ROADWAY AND RAILROAD TRANSPORTATION .....	5-91
5.6.1	Affected Environment .....	5-91
5.6.2	Potential Effects .....	5-107
5.6.3	Proposed Design Features Intended to Reduce Impacts.....	5-129
5.7	AIR QUALITY .....	5-130
5.7.1	Regulatory Overview and Air Quality Guidelines .....	5-130
5.7.2	Affected Environment .....	5-131
5.7.3	Effects .....	5-137
5.8	LAND USE .....	5-141
5.8.1	Affected Environment .....	5-142
5.8.2	Potential Effects on Land Use .....	5-152
5.8.3	Proposed Design Features Intended to Reduce Impacts.....	5-152
5.9	SOCIOECONOMIC ENVIRONMENT .....	5-153
5.9.1	Affected Environment .....	5-153
5.9.2	Construction Effects .....	5-158
5.9.3	Operational Effects.....	5-160
5.9.4	Proposed Design Features Intended to Reduce Impacts.....	5-163

5.10 ENVIRONMENTAL JUSTICE .....5-164  
 5.10.1 Affected Environment .....5-164  
 5.10.2 Effects .....5-167  
 5.10.3 Proposed Design Features Intended to Reduce Impacts .....5-168  
 5.11 PARKS AND RECREATIONAL FACILITIES .....5-168  
 5.11.1 Affected Environment .....5-169  
 5.11.2 Potential Effects on Parks and Recreational Facilities .....5-170  
 5.11.3 Proposed Design Features Intended to Reduce Impacts .....5-170  
 5.12 PUBLIC SERVICES .....5-173  
 5.12.1 Affected Environment .....5-173  
 5.12.2 Potential Effects on Public Services.....5-174  
 5.12.3 Proposed Design Features Intended to Reduce Impacts to Public Services.....5-175  
 5.13 UTILITIES.....5-175  
 5.13.1 Affected Environment .....5-175  
 5.13.2 Potential Effects on Utilities .....5-176  
 5.13.3 Proposed Design Features Intended to Reduce Impacts .....5-177  
 5.14 RELATIONSHIP TO OTHER PLANS AND POLICIES.....5-177  
 5.14.1 Affected Environment .....5-177  
 5.14.2 Project Effects on Relationship to Plans and Policies .....5-185  
 5.14.3 Proposed Design Features Intended to Reduce Impacts .....5-185  
 5.15 OTHER RESOURCE AREAS TO BE ADDRESSED AT A LATER DATE .....5-185  
 5.15.1 Noise .....5-186  
 5.15.2 Energy .....5-186  
 5.15.3 Aesthetics.....5-186  
 5.15.4 Light and Glare .....5-187  
 5.15.5 Commercial and Recreational Navigation .....5-188  
 CHAPTER 6 REFERENCES..... 6-1

**TABLES**

Table 2-1 Anticipated Permits and Authorizations for the Gateway Pacific Terminal ..... 2-2  
 Table 2-2 Anticipated Permits and Authorizations for the Custer Spur Improvements ..... 2-5  
 Table 4-1 Summary of Land Ownership and Acreage in the Project Area ..... 4-2  
 Table 4-2 Commodity Handling Capacity by Terminal Development Phase and Location ..... 4-49  
 Table 4-3 Estimated Number of Terminal Employees by Shift for Each Operational Phase .... 4-50  
 Table 4-4 Likely Commodities to Be Handled at the Terminal and Their Properties ..... 4-52  
 Table 4-5 Trains per Day by Operation Phase ..... 4-53  
 Table 4-6 Vessels per Year by Vessel Class and Operations Phase..... 4-61  
 Table 5-1 Pending Studies and Reports ..... 5-1  
 Table 5-2 Mapped Soil Series in the Project Vicinity ..... 5-9  
 Table 5-3 Migratory Bird Species Identified in the Project Area ..... 5-19  
 Table 5-4 Non-Migratory Bird Species Identified During Field Investigations..... 5-20  
 Table 5-5 WDFW Priority Species that may occur in Whatcom County ..... 5-23  
 Table 5-6 Federally Listed Species that Could Occur Near the Strait of Georgia Identified by NOAA Fisheries Service..... 5-37  
 Table 5-7 Federally Listed Species that Could Occur Near the Strait of Georgia Identified by the USFWS ..... 5-37

Table 5-8	Marine State Priority Species that Could Occur at the Gateway Pacific Terminal Site .....	5-38
Table 5-9	Groundfish on the State Priority List that Could Occur near the Gateway Pacific Terminal Site.....	5-45
Table 5-10	Summary of Streams and Wetlands in the Project Vicinity that Drain into the Birch Bay Watershed .....	5-60
Table 5-11	Stream Characteristics in the Gateway Pacific Terminal Watershed .....	5-66
Table 5-12	Summary of Stream 1 Conditions by Reach .....	5-67
Table 5-13	Characteristics and Ratings of Wetlands on the Pacific International Terminals Property.....	5-69
Table 5-14	Impacts to Gateway Pacific Terminal Streams and Drainages .....	5-73
Table 5-15	Temporary Wetland Impacts .....	5-74
Table 5-16	Approximate Area of Compensatory Mitigation Required For Category III Wetland Impacts by Whatcom County .....	5-78
Table 5-17	Permanent Wetland Impacts and Proposed Mitigation.....	5-82
Table 5-18	Archaeological Sites in or near the APE <sup>1</sup> .....	5-88
Table 5-19	2010 PM Peak Hour Level of Service, Delay, and Volume/Capacity (V/C) Ratio....	5-101
Table 5-20	Collision Rate and Frequency – January 1, 2007 to December 31, 2010.....	5-102
Table 5-21	Level of Service Criteria for Two-Way Stop-Controlled Intersections .....	5-104
Table 5-22	2010 PM Peak Hour Level of Service and Delay Without and With Train Crossings	5-107
Table 5-23	2026 PM Peak Hour Level of Service with and without Project .....	5-125
Table 5-24	2026 PM Peak Hour Delay, and Volume/Capacity (V/C) Ratio with and without Project .....	5-126
Table 5-25	2026 PM Peak Hour Level of Service and Delay Without and With Project Volume with Train Crossings .....	5-127
Table 5-26	2026 PM Peak Hour Level of Service with and without Signalization Improvements	5-129
Table 5-27	Summary of Measured Ambient Pollutant Concentrations .....	5-132
Table 5-28	Pertinent Comprehensive Plan Goals and Policies .....	5-151
Table 5-29	General Population and Demographic Information, Whatcom County and State of Washington.....	5-154
Table 5-30	Employment by Industry, Whatcom County and the State of Washington, First Quarter 2010 (Preliminary).....	5-155
Table 5-31	Economic Characteristics for Whatcom County and the State of Washington.....	5-156
Table 5-32	2010 Combined State and Local Sales and Use Taxes, Locations within Whatcom County .....	5-157
Table 5-33	Terminal Construction by Stage.....	5-159
Table 5-34	Socioeconomic Characteristics of the Lummi and Nooksack Reservations.....	5-166

**FIGURES**

Figure 1-1	Vicinity Map .....	1-3
Figure 1-2	Proposed Project Layout.....	1-7
Figure 1-3	Adjacent Land Owners.....	1-11
Figure 4-1	East Loop .....	4-5
Figure 4-2	Example Conveyor Cross-Section .....	4-9
Figure 4-3	Example of Covered Conveyor .....	4-11
Figure 4-4	West Loop .....	4-13
Figure 4-5	Example Shed Dimensions.....	4-17



Figure 4-6	Example Storage Silos .....	4-19
Figure 4-7	Shared Services Area .....	4-23
Figure 4-8	Wharf and Access Trestle .....	4-25
Figure 4-9	Example Cross-Section of Access Trestle.....	4-27
Figure 4-10	Example Shiploader .....	4-29
Figure 4-11	Existing Rail Facilities and Proposed Custer Spur Improvements.....	4-33
Figure 4-12	Proposed Custer Spur Improvements .....	4-35
Figure 4-13	Proposed BNSF Typical Rail Section .....	4-37
Figure 4-14	Proposed Elliott Yard Improvements .....	4-39
Figure 4-15	Proposed Terminal Stormwater Facilities .....	4-41
Figure 4-16	Example Rail Car Unloading Shed .....	4-55
Figure 4-17	Schematic Drawing and Photograph of Example Passive Enclosure Dust System..	4-57
Figure 4-18	Schematic Drawing of Example Fogger System.....	4-59
Figure 5-1	USGS Topographic Map .....	5-3
Figure 5-2	Natural Resources Conservation Service Soils Map.....	5-7
Figure 5-3	Existing Vegetation Types .....	5-15
Figure 5-4	Vegetation Impacts: Proposed Action.....	5-25
Figure 5-5	Existing Conditions: Nearshore Communities.....	5-31
Figure 5-6	Cherry Point Herring Spawn Area .....	5-41
Figure 5-7	Macroalgae Enhancement Area .....	5-53
Figure 5-8	Photo of Abandoned Belt Conveyor to Be Removed .....	5-55
Figure 5-9	Watersheds within the Gateway Pacific Terminal Project Area.....	5-61
Figure 5-10	Existing Stream Network, Wetlands, and Hydrologic Flow.....	5-63
Figure 5-11	Summary of Direct Fill Impacts to Wetlands within the Gateway Pacific Terminal Project Area .....	5-71
Figure 5-12	Proposed Wetland Mitigation Areas .....	5-79
Figure 5-13	Intersection Geometry: Intersections #1 to #15 .....	5-93
Figure 5-14	Existing Volumes 2010 (PM) Peak Hour Turning Movement Volumes: Intersection #1 to #12.....	5-97
Figure 5-15	Existing Volumes 2010 (PM) Peak Hour Turning Movement Volumes: Intersection #13 to #15.....	5-99
Figure 5-16	At-Grade Rail Crossings.....	5-105
Figure 5-17	Future Volumes 2026 (PM) Peak Hour without Project: Intersection #1 to #12.....	5-109
Figure 5-18	Future Volumes 2026 (PM) Peak Hour without Project: Intersection #13 to #15....	5-111
Figure 5-19	Outbound Employee Trip Distribution.....	5-115
Figure 5-20	Future Volumes 2026 (PM) Peak Hour Project Related Volume: Intersection #1 to #12.....	5-117
Figure 5-21	Future Volumes 2026 (PM) Peak Hour Project Related Volume: intersection #13 to #15.....	5-119
Figure 5-22	Future Volumes 2026 (PM) Peak Hour Volume with Project: Intersection #1 to #125-121	
Figure 5-23	Future Volumes 2026 (PM) Peak Hour Volume with Project: Intersection #13 to #15.....	5-123
Figure 5-24	5-Year Wind Rose (BP Cherry Point) .....	5-136
Figure 5-25	Comprehensive Plan Map .....	5-145
Figure 5-26	Zoning Map .....	5-147
Figure 5-27	Shoreline Master Plan Designation Map.....	5-149
Figure 5-28	Map of Parklands in Vicinity .....	5-171
Figure 5-29	Cherry Point Aquatic Reserve Boundary .....	5-181



## **CHAPTER 1 INTRODUCTION**

Pacific International Terminals, Inc. (Pacific International Terminals), a subsidiary of SSA Marine, is proposing to develop the Gateway Pacific Terminal (the “Terminal”) at Cherry Point in Whatcom County, Washington (Figure 1-1). Designed for export and import of dry bulk commodities, the proposed Terminal would include a deep-draft wharf with access trestle, dry bulk materials handling and storage facilities, and rail transportation access. This Project Information Document describes the proposed project, the permits and approvals required to construct and operate the project, the environmental conditions of the project area, and the effects of the proposed project.

The proposed project would meet three principal needs, each of which provides a basis for the proposed project:

1. The need to ship bulk commodities to and from international markets to meet current and future market demand;
2. The need for a multimodal deep-water bulk marine terminal in the Puget Sound region; and
3. The need for community and economic development.

Activities associated with development of the proposed Terminal started in the late 1980s and have included completion of numerous environmental assessments and the issuance of land-use and shoreline permits by Whatcom County. The environmental permitting process for the Terminal is currently being coordinated through a collaborative, multi-agency permitting team (MAP Team) led and administered by the State of Washington Governor’s Office of Regulatory Assistance (ORA). The permitting process will include a further detailed environmental review of the proposed project under the National Environmental Policy Act (NEPA) and Washington State Environmental Policy Act (SEPA).

### **1.1 PURPOSE OF THE PROJECT INFORMATION DOCUMENT**

The purpose of this Project Information Document is to provide the public, the MAP Team, decision-makers, and other stakeholders, including affected Native American Tribes, with a detailed description of the proposed project, the potential environmental effects of the project, and measures incorporated into the proposed project to reduce such effects. It discusses the purpose of the project in the context of international trade and the need for the project to provide dry bulk terminal capacity in the Pacific Northwest. The Project Information Document provides a succinct compendium of project scope, construction, operation, and environmental information to support the various permitting reviews to be conducted by members of the MAP Team. Pacific International Terminals intends to incorporate the proposed design measures identified in this Project Information Document into its applications for

permits and other approvals. The contents of the Project Information Document may also serve as a useful resource in the completion of required environmental reviews by the MAP Team, including the Environmental Impact Statement (EIS) to be prepared pursuant to NEPA and SEPA.

The Project Information Document includes the most current information available; Pacific International Terminals is continuing to conduct additional engineering, design work, and environmental and other studies in support of the project. When the environmental studies are complete, amendments or addenda to this Project Information Document will be issued to supplement the information presented here.

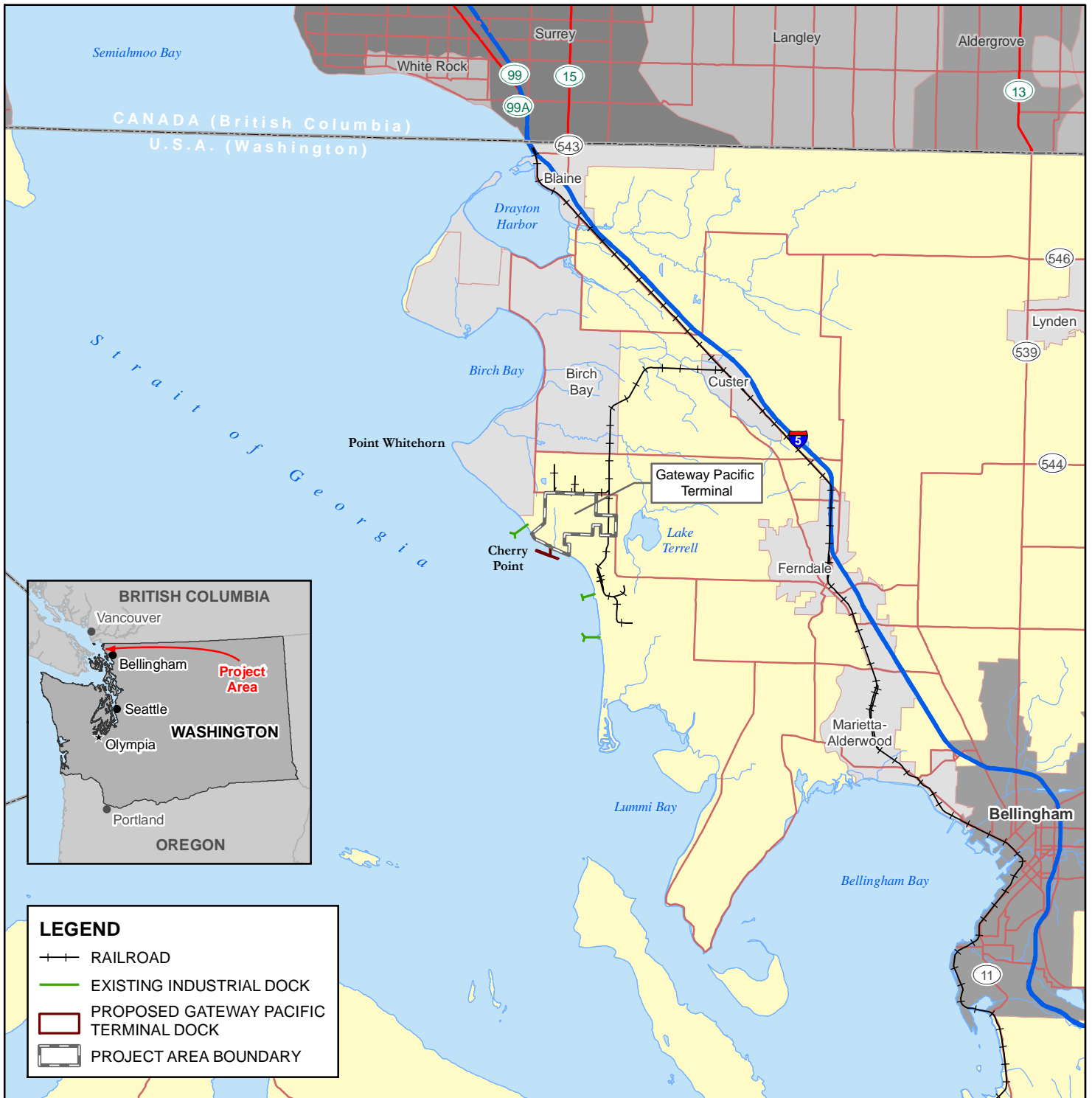

**LEGEND**

- +—+— RAILROAD
- EXISTING INDUSTRIAL DOCK
- ▭ PROPOSED GATEWAY PACIFIC TERMINAL DOCK
- ▭ PROJECT AREA BOUNDARY

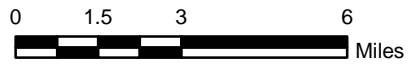

				CLIENT: <b>PACIFIC INTERNATIONAL TERMINALS, INC.</b>	
PROJECT: <b>PROPOSED GATEWAY PACIFIC TERMINAL</b>		DWN BY: SD	DATUM: NAD83	DATE: FEBRUARY 2011	
TITLE: <b>VICINITY MAP</b>		CHK'D BY: TQ	REV. NO.: 1	PROJECT NO.: 091515338C-18-01	
		PROJECTION: WA SP North, Ft.	SCALE: 1 inch=3 miles	FIGURE No.: <b>FIGURE 1-1</b>	



## 1.2 PROJECT OVERVIEW AND KEY FEATURES

Gateway Pacific Terminal would serve as a deep water, multimodal Terminal for the export and import of dry bulk commodities<sup>1</sup> between rail and oceangoing vessels. The proposed Terminal project area encompasses 1,200 acres. The proposed Terminal's infrastructure would be developed on approximately 350 acres within the total 1,200-acre project area (Figure 1-2). The project area is located in the Cherry Point Industrial Urban Growth Area (UGA), which is zoned for heavy-impact industrial land use. Under Whatcom County's Shoreline Management Program, the property is designated as part of the Cherry Point Management Area, where port and water-dependent industrial facilities are permitted. Whatcom County previously issued a Shoreline Substantial Development Permit and a Major Development Permit to Pacific International Terminals authorizing the construction and operation of the Terminal. Additional details about land use and zoning issues and the status of permitting for the project are presented in Sections 2.1 and 5.8.

The proposed \$665 million Terminal project responds to existing market needs and advances important federal, state, and local governmental objectives, including:

- Growth in global demand for dry bulk commodities;
- Whatcom County's interest in the further industrial development of the Cherry Point Industrial UGA; and,
- Continuing economic development initiatives undertaken by both the federal government and the State of Washington that seek to expand exports from Washington to rapidly developing foreign markets in Asia and elsewhere.

The Terminal would enhance the economy of Northwestern Washington by:

- Supporting approximately 21.7 million person hours of construction-related employment, which would generate approximately \$411 million in wages, approximately \$624 million in local purchases, and approximately \$70.8 million in state and local tax revenues during the construction period of the Terminal (Martin Associates 2011);
- Continued development of the Cherry Point Industrial UGA;

---

<sup>1</sup> Dry bulk commodities include forest, agricultural, or mining products that are particulate in nature; are minimally processed, if at all; and are not bagged or wrapped. Dry bulk commodities are mainly transported as shiploads or trainloads, and handled using large-capacity containers or storage pads and dedicated transfer machinery generally incorporating conveyor systems. Dry bulk commodities include, for example, grain, iron ore, salts, coal, and alumina. Bulk commodities are the "raw material" upon which many industrial processes depend.

- Sustaining approximately 1,230 jobs in the regional economy, including approximately 430 permanent, family-wage jobs at the Terminal and in the rail and shipping industry during operation of the Terminal;
- Generating approximately \$11 million in annual state and local tax revenues;
- Generating approximately \$17 million in local purchases by businesses that support the Terminal;
- Generating approximately \$126 million in regional economic activities through payrolls and purchase of goods and services; and
- Generating approximately \$1.4 billion in revenue for businesses providing handling, vessel, and other services to the Terminal.

The proposed Terminal would include the following key facilities:

- Wharf and Trestle – The proposed Terminal's wharf and trestle would be located in an area where deep water is close to shore allowing the Terminal to accept the largest and most economic dry bulk carriers currently in service. The wharf would include three deep-water berths suitable for calls by Panamax<sup>2</sup> and Capesized<sup>3</sup> bulk carriers. The ability to accommodate large vessels would minimize vessel traffic and maximize the efficiency of Terminal operations.
- Materials Handling and Storage – The Terminal's material handling and storage areas would consist of two areas: one for outside commodity storage and the other for covered and silo storage.<sup>4</sup> The storage areas would be serviced by two rail loops and other miscellaneous support facilities, including stormwater systems. Materials unloading, handling, and loading equipment would be installed that best protects the safety of employees and protects the environment during Terminal operations.

---

<sup>2</sup> Panamax vessels are the largest vessels that currently transit the Panama Canal and have capacities of 65,000 to 85,000 long tons dead weight (dwt).

<sup>3</sup> Capesize vessels are defined as a class of bulk carrier with beams (widths) greater than 105.6 feet that cannot transit the Panama Canal because they are too wide, and therefore must travel south around the Cape of Good Hope or Cape Horn. The majority of the present Capesize fleet has capacities between 160,000 and 180,000 dwt (US Maritime Administration 2009c).

<sup>4</sup> Certain dry commodities, such as grain and potash, are ruined with moisture and thus would need to be stored in a covered structure.



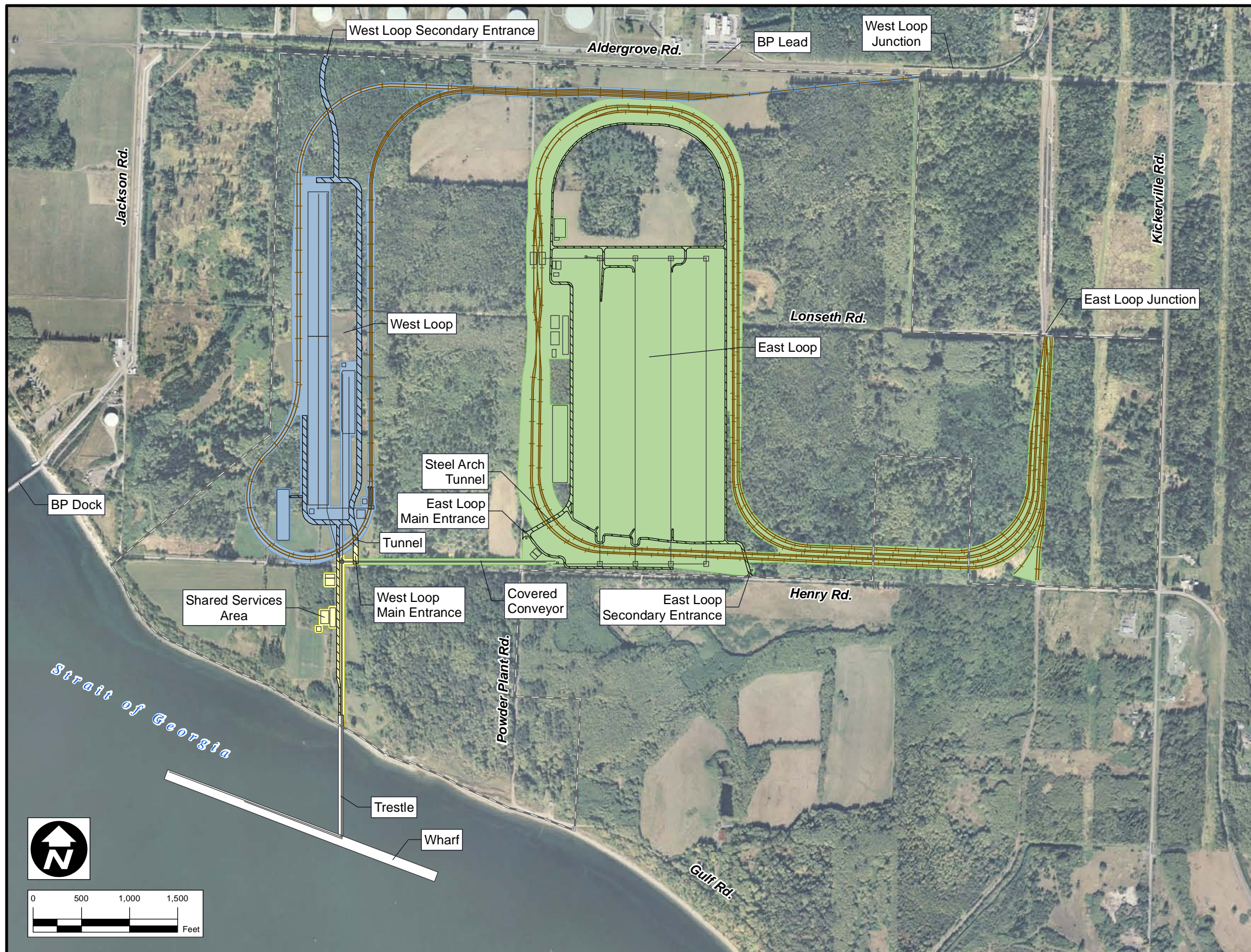

**LEGEND**

- NEW RAILWAY TRACK
- ROAD
- EAST LOOP
- WEST LOOP
- SHARED SERVICES AREA
- TRESTLE & WHARF
- PROJECT AREA BOUNDARY

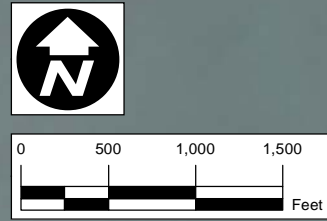

Source:  
Ausenco Sandwell, 154199-A100-42S01.dwg (Rev. J), 12/24/2010.



CLIENT:  
**PACIFIC INTERNATIONAL TERMINALS, INC.**

DWN BY: SD  
CHK'D BY: KD  
DATUM: NAD83  
PROJECTION: WA SP North, Ft.  
SCALE: 1 inch = 1,100 feet

PROJECT:  
**PROPOSED GATEWAY PACIFIC TERMINAL**

TITLE:  
**PROPOSED PROJECT LAYOUT**

DATE:  
FEBRUARY 2011

PROJECT NO.:  
091515338C-18-01

REV. NO.:  
1

FIGURE NO.:  
FIGURE 1-2



- Rail Connection –The project area is served by BNSF Railway Company's (BNSF Railway) Custer Spur Industrial rail line (Custer Spur), which connects to BNSF Railway's main line at Custer, Washington, approximately 6 miles from the project area (Figure 1-1). The Custer Spur provides the Terminal's access to the nationwide rail network.

The Terminal would be developed to have the capacity to export and import up to 54 million metric tons per annum (Mtpa) of dry bulk commodities. The type and quantity of dry bulk commodities that would be managed will likely change over time and would depend on international market conditions and customer demands. Products to be exported to the international market would include coal, grain products, potash, calcined petroleum coke, and other bulk commodities (Chapter 4). The main features of the proposed Terminal are shown on Figure 1-2. A more detailed description of the proposed Terminal is provided in Chapter 4.

Pacific International Terminals expects to construct the Terminal in two stages. The first stage is planned to commence in early 2013 after completion of necessary environmental reviews and issuance of required federal, state, and Whatcom County permits and authorizations. The second stage of construction would commence during the completion of Stage 1 and be completed in 2017. Additional materials handling equipment would be added in subsequent years in response to operational needs.

The Terminal layout and design have evolved from the project design previously permitted for the Gateway Pacific Terminal. The current design reflects changes in international dry bulk commodity demand and vessel size and incorporates changes based on requests from regulatory authorities and ongoing discussions with stakeholders. The proposed design and operational plan for the Terminal reflect a thorough consideration of potential environmental impacts and Tribal concerns. The resulting design includes proposed measures to mitigate these concerns. These proposed measures are included as committed design features of the proposed project. The plan also includes measures required to meet existing regulatory standards regarding environmental protection (Chapters 4 and 5). A summary of these measures is provided as Appendix A.

### **1.3 PROJECT LOCATION**

The project area is located at Cherry Point, a small promontory of land on the eastern shore of the Strait of Georgia on the west coast of Washington State. The project area is located approximately 18 miles northwest of the City of Bellingham, 5 miles west of Ferndale, and 17 miles south of the US-Canada border (Figure 1-1). Existing major industrial facilities in the Cherry Point Industrial UGA include the BP Cherry Point Refinery, the ConocoPhillips Ferndale Refinery, and the ALCOA-Intalco Works; industrial piers currently serve all three facilities.

Cherry Point has the following key advantages as a location for development of a dry bulk terminal:

- It has a natural deep-water, nearshore marine location that does not require dredging for development or maintenance of a deep-water wharf.
- Cherry Point's natural deep water enables the proposed wharf to accommodate up to 80-foot average draft vessels, including the largest oceangoing dry bulk cargo vessels known as Capesize and Panamax vessels.
- It is a naturally protected inland marine water.
- It has adequate available land zoned as Heavy Impact Industrial and a shoreline designation that supports water-dependent industrial use.
- It has current industrial water supply capacity and electrical infrastructure.
- It has easy access to Interstate 5 (I-5) via State Route (SR) 548 (approximately 6 miles).
- It has a ready connection to a Class 1 railroad (BNSF Railway).
- It has an adequate, mainly flat area for short-term storage, transfer, and handling of commodities.
- It has sufficient upland area to process a complete train approximately 8,500 feet long without interfering with mainline traffic.

#### **1.4 PROJECT DEVELOPER AND PROPERTY OWNERSHIP**

The Terminal would be built, owned, and operated by Pacific International Terminals, Inc., a wholly owned subsidiary of SSA Marine, Inc., a Carrix Company. Pacific International Terminals is the project applicant for development of the Terminal. BNSF Railway will be the project applicant for improvements to Custer Spur that would occur only if the Terminal is built.

The upland portions of the Terminal would be built on approximately 350 acres of a 1,200-acre assemblage of private property. The wharf and the major length of the trestle would be located on state-owned tidelands that would be leased from the Washington Department of Natural Resources (WDNR). Pacific International Terminals will petition Whatcom County for vacation of specific County-owned rights-of-way within the project area. Adjacent landowners include BP, WDNR, ALCOA, BNSF Railway, and one other private property owner (Figure 1–3).

PARCEL OWNER:	
1	ATLANTIC RICHFIELD CO.
2	BNSF RAILWAY CO.
3	BP WEST COAST PRODUCTS LLC
4	CAMPBELL LAND CORPORATION
5	DAVID & KATHLEEN WELLS
6	BAKER SEPTIC LLC (79%) & DAVID & KATHLEEN WELLS (21%)
7	GARRETT & LAWANDA LEMLEY
8	L. JAMES & LINDA KOLBO
9	LGJK LLC
10	MELVIN & JEANNE MARCOUX
11	WASHINGTON STATE DEPARTMENT OF NATURAL RESOURCES (STATE LANDS DIVISION)
12	CHERRY POINT INDUSTRIES LLC / CHERRY POINT INDUSTRIAL PARK
13	WASHINGTON STATE DEPARTMENT OF NATURAL RESOURCES TIDELAND

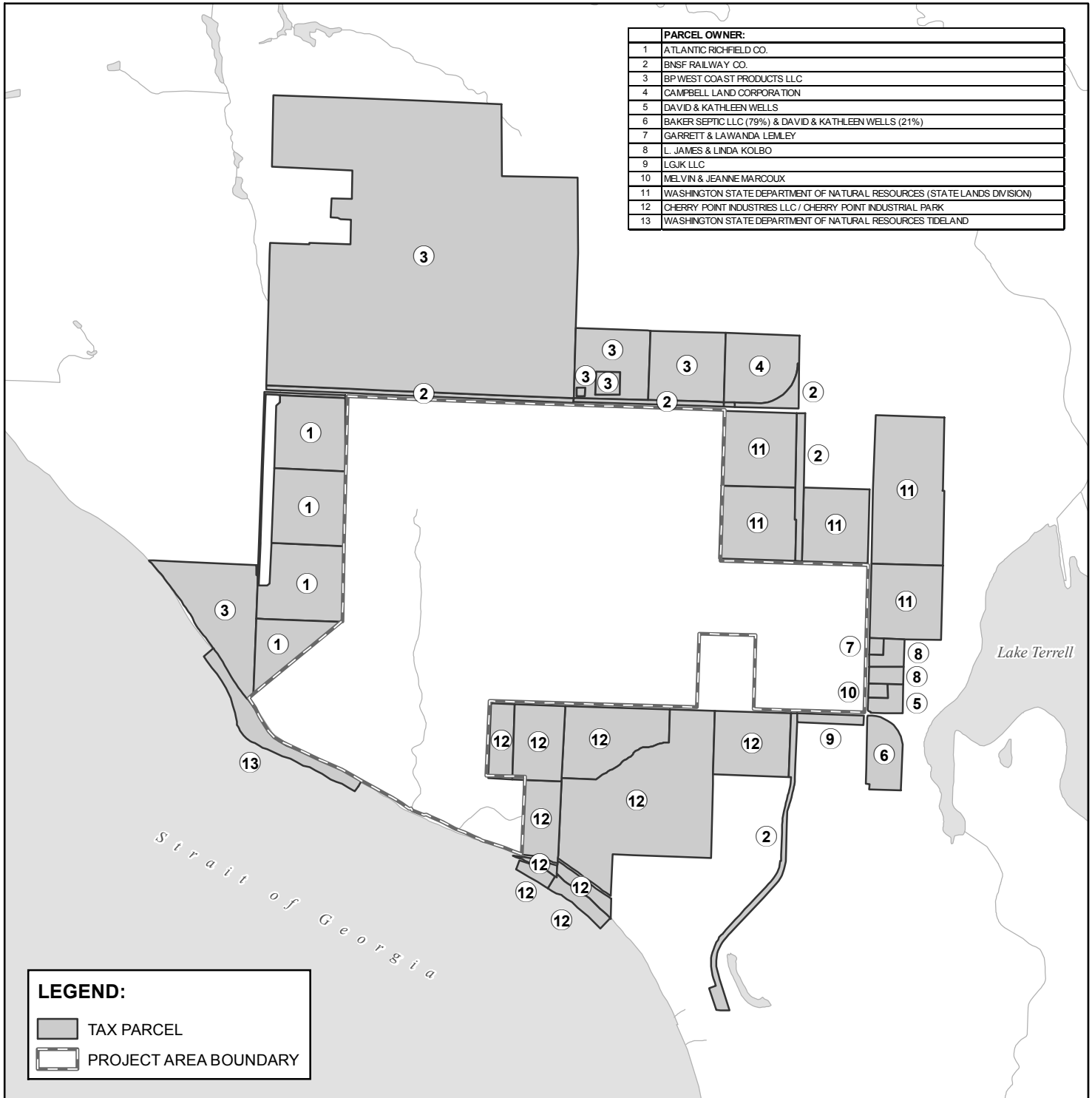

LEGEND:	
	TAX PARCEL
	PROJECT AREA BOUNDARY

Source:  
 Tax Parcel data obtained from Whatcom County Assessor's Office and is current as of 02/09/2011.  
 Tideland data obtained from Washington Department of Natural Resources on 11/03/2010: <http://fortress.wa.gov/dnr/app1/dataweb/dmmatrix.html>

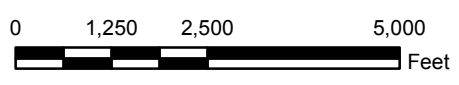

			CLIENT:				
			<b>PACIFIC INTERNATIONAL TERMINALS, INC.</b>				
PROJECT:	<b>PROPOSED GATEWAY PACIFIC TERMINAL</b>  <b>ADJACENT LAND OWNERS</b>	DWN BY:	SD	DATUM:	NAD83	DATE:	FEBRUARY 2011
TITLE:		CHK'D BY:	KD	REV. NO.:	1	PROJECT NO.:	091515338C-18-01
		PROJECTION:	WA SP North, Ft.	SCALE:	1 inch=2,500 feet	FIGURE No.:	FIGURE 1-3



## **1.5 CONTENTS OF THE PROJECT INFORMATION DOCUMENT**

Following this introduction, the Project Information Document contains the following additional information:

- Chapter 2, Project Permitting, lists and describes the permits and approvals to be obtained by Pacific International Terminals and BNSF Railway for development of the proposed Terminal and upgrades to the Custer Spur rail line.
- Chapter 3, Purpose and Need, describes the purpose and need for the project in reference to the world market for dry bulk commodities, the need for west coast facilities to export such commodities, the uniqueness of the Cherry Point location to serve such a need, and the need for local, state, and national economic development.
- Chapter 4, Project Description, provides a detailed description of the proposed project, including the wharf and trestle, materials handling and storage areas, rail loops, and upgrades to the Custer Spur. It includes a description of the construction sequence and proposed construction schedule.
- Chapter 5, Affected Environment / Environmental Consequences, describes the existing conditions of the project area, potential environmental impacts, and proposed design features intended to reduce any impacts.





## **CHAPTER 2 PROJECT PERMITTING**

Pacific International Terminals began initial permitting and environmental assessment for the Gateway Pacific Terminal in the late 1980s, and in 1997 received permits for what was then considered the first phase of the project. Since then, Pacific International Terminals has completed numerous additional studies and undertaken extensive collaboration with regulatory agencies, affected Native American Tribes, and other stakeholders. The studies and consultation have led to many project modifications and other changes intended to, among other considerations, mitigate impacts and address stakeholder concerns on earlier designs. This chapter summarizes the permits and authorizations that have been issued to date and outlines the remaining permits and approvals needed prior to construction of the project.

### **2.1 PERMITS AND AUTHORIZATIONS**

Numerous permits and authorizations will be required from various federal, state, and local agencies to construct and operate the Gateway Pacific Terminal and for improvements to the Custer Spur. This section provides an overview of the permits that have already been retained and those that will be required for the project, organized by the responsible agency or jurisdiction.

#### **2.1.1 Whatcom County**

Several permits will be required from Whatcom County, as shown on Table 2-1. This section describes Whatcom County permitting activities conducted to date and summarizes additional anticipated permitting activities.

##### **2.1.1.1 Whatcom County Permitting Activities from 1992 to Present**

In 1992, after the completion of environmental studies and reviews, Pacific International Terminals submitted a SEPA Environmental Checklist and applications for a Shoreline Substantial Development Permit and a Major Development Permit to Whatcom County. Whatcom County determined that the application was complete and vested the project under the then existing Whatcom County Code and Shoreline Management Plan. In late 1992, Whatcom County issued a *Notice of Determination of Significance* and a request for comments on the scope of a SEPA EIS. Whatcom County subsequently retained a team of consultants to develop the EIS in accordance with applicable requirements. The Draft and Final SEPA EIS documents were published in 1996 and 1997, respectively (Whatcom County 1996 and 1997).

**Table 2-1 Anticipated Permits and Authorizations for the Gateway Pacific Terminal**

<b>Permit/Authorization Name</b>	<b>Lead Agency</b>	<b>Regulated Activity</b>	<b>Regulated Terminal Project Component</b>
Clean Water Act, Section 404 and Rivers and Harbors Act Section 10 Permit	USACE	Discharge of dredge or fill material into navigable waters and construction in or over navigable waters	All components
National Historic Preservation Act, Section 106 Review	USACE	Review of any action with a federal nexus	All components
National Environmental Policy Act	USACE	Review of any action with a federal nexus	All components
Private Aids to Navigation	US Coast Guard	Installation of fixed structure or floating object within waters of the United States	Wharf, Trestle, & ship movements
Endangered Species Act, Section 7 Consultation	USFWS and NOAA Fisheries	Potential impacts to federally listed species and/or their designated critical habitats	All components
Marine Mammal Protection Act, Marine Mammals	NOAA Fisheries	Potential impacts to marine mammals, including whales.	Wharf, Trestle, & ship movements
Magnuson-Stevenson Act	NOAA Fisheries	Potential impacts to designated Essential Fish Habitat	Wharf & Trestle
Hydraulic Project Approval(s)	WDFW	Project uses, diverts, or changes flow or bed of waters of the state	All components
Aquatic Lease Agreement	WDNR	Long-term lease of state-owned aquatic lands	Wharf & Trestle on State Lands
Clean Water Act, Section 401 Water Quality Certification	Ecology	Discharges to waters of the US, including wetlands	All components
Coastal Zone Management Consistency Determination	Ecology	Qualifying activity within a coastal county	Wharf & Trestle
NPDES General Industrial Stormwater Permit	Ecology	Discharge of stormwater to surface waters	All components
NPDES General Stormwater Permit for Construction	Ecology	Construction activities that disturb 1 acre or more	Upland components
Clean Air Act – Order of Approval to Construct	Northwest Clean Air Agency	New or modified source of air pollution	All components
Building Permits	Whatcom County	Constructing any permanent structure	All components
Certificate of Occupancy	Whatcom County	Begin use of constructed building	All components
Major Project Permit	Whatcom County	Construction of the Terminal	All components
State Environmental Policy Act Threshold Determination	Whatcom County	Any non-exempt development activities	All components
Street Vacation	Whatcom County	Vacation of public rights-of-way	Whatcom County rights-of-way

### 2.1.1.2 Shoreline Substantial Development Suit and Settlement Agreement

In 1997, Whatcom County issued a Shoreline Substantial Development Permit (SSD permit – SHS92-0020) and a Major Development Permit (MD permit – MDP92-0003) to Pacific International Terminals

allowing construction and operation of the Terminal. The SSD permit was subsequently appealed<sup>1</sup> by the Washington State Department of Ecology (Ecology), the Washington Department of Fish and Wildlife (WDFW), and a coalition of five environmental groups represented by the Washington Environmental Council. The parties settled the appeal in 1999 with a formal Settlement Agreement. The execution of the Settlement Agreement<sup>2</sup> among all parties added a number of conditions to the 1997 SSD permit. These conditions are shown in Appendix A.

In 2009, Whatcom County administratively affirmed the effectiveness of the 1997 SSD permit and Settlement Agreement and determined that no additional review under the County's Shoreline Management Plan would be required for the project to be developed as it was permitted.

The 1997 SSD permit provides for construction and operation of the proposed wharf and its connecting trestle as shown in the 1996 Draft EIS (Whatcom County 1996; note: the upland portion of the project was outside the Shoreline Management Act jurisdiction). The current development plan proposes to use the permitted wharf and trestle configuration. The configuration is the same as the design included in the approved 1997 SSD permit, except where design features have been altered either to comply with, or as allowed by, the conditions of the Settlement Agreement.

The County's 2009 administrative decision also reaffirmed the 1997 MD permit, which permitted construction and operation of the western portion of the project. The current development plan proposes to retain the purpose, operational characteristics, and infrastructure included in the original design, but changes the layout. However, the proposed Terminal now includes a second materials handling and storage area and its infrastructure, which requires environmental review and permitting.

Pacific International Terminals has been working to implement the Settlement Agreement conditions since 1999. The parties are currently negotiating the resolution of final issues associated with remaining tasks to be performed under the Settlement Agreement by Pacific International Terminals prior to and during construction, and its future obligations during operation of the Terminal.

### **2.1.1.3 Additional Whatcom County Permitting Activity**

Because the upland portion of the Terminal design has changed from the previously permitted project, it is anticipated that a Major Project Permit (MPP) will be required. This process will require staff review, a public hearing before the Hearing Examiner, and, probably, a closed record hearing before the County Council. No changes to the Shoreline Substantial Development Permit for the wharf and

---

<sup>1</sup> Neither the SEPA Final EIS nor the 1997 Major Development Permit were appealed.

<sup>2</sup> Shoreline Hearings Board Appeals numbers 97-22 and 97-23, 1999; called 'the Settlement Agreement' in this document.

trestle are required. Once the MPP is granted, several additional County permits will be acquired, including building permits.

To issue the MPP and associated permits, the County will also be required to complete additional environmental review under SEPA. The County has been identified as the lead agency for compliance with SEPA and will coordinate preparation of an EIS as a co-lead agency with the US Army Corps of Engineers (USACE).

### **2.1.2 Federal Permitting**

Construction of project facilities that affect waters of the US, including wetlands, require an individual permit under Section 404 of the Clean Water Act, and a permit for construction in navigable waters under Section 10 of the Rivers and Harbors Act. The USACE was identified in 1992 as the lead federal agency for the Terminal project and has continued responsibility for NEPA compliance.

Pacific International Terminals filed an initial USACE permit application (USACE Application 91-2-00203-R) for these permits after execution of the 1999 Settlement Agreement. In 2006, at the request of USACE, and given the changing nature of the project and the passage of time, Pacific International Terminals officially withdrew its original application with the express understanding that a new application would be filed in its place, without prejudice, to appropriately address environmental documentation and compliance requirements. A Joint Aquatic Resources Permit Application (JARPA) was filed for the Terminal by Pacific International Terminals on February 28, 2011, with the USACE, other appropriate agencies, and the MAP Team.

BNSF's Custer Spur improvements are expected to impact jurisdictional wetlands and streams and will also require an individual Section 404 permit. The permit will also be required for expansion and upgrades to crossings of California Creek and Terrell Creek, including:

- Construction of bridge structures spanning the creeks' channels to support additional rail infrastructure; and
- Restoration of a portion of California Creek to realign it to a more natural right-angle crossing under the BNSF infrastructure.

The USACE has been identified as the lead federal agency and will be responsible for NEPA compliance for BNSF Railway's Custer Spur improvements as part of the Terminal project. This Project Information Document evaluates the effects of both Terminal development and the Custer Spur improvements to support future NEPA and SEPA processes concerning these actions.

Other permits and approvals applicable to BNSF Railway's actions are described in Table 2-2.

**Table 2–2 Anticipated Permits and Authorizations for the Custer Spur Improvements**

<b>Permit/Authorization Name</b>	<b>Issuing/Performing Agency</b>	<b>Regulated Activity</b>	<b>Regulated Rail Project Components</b>
Clean Water Act, Section 404	USACE	Discharge of dredge or fill material into navigable waters	All components
Clean Water Act, Section 401 Water Quality Certification	Ecology	Discharge to water, excavation in water, discharges to special aquatic sites	All components
NPDES General Stormwater Permit for Construction	Ecology	Construction activities that disrupt 1 acre or more	All components
National Historic Preservation Act, Section 106 Review	USACE	Review of any action with a federal nexus	All components
Coastal Zone Management Act Consistency	Ecology	Review of any action with a coastal resource nexus	All components
Endangered Species Act, Section 7 Consultation	USFWS and NOAA Fisheries	Potential impacts to federally listed species and/or their designated critical habitats	All components

### 2.1.3 State Approvals and Leases

At the time the Shoreline Substantial Development and Major Development Permit applications were submitted in 1992, Pacific International Terminals also submitted an application and initiated discussions with the Washington Department of Natural Resources (WDNR) to secure a commercial tidelands lease. The negotiation process was placed on hold in 2002 pending the release and approval of the *Cherry Point Environmental Aquatic Reserve Management Plan* (WDNR 2010). The final plan was released in November 2010.

Other state approvals, such as Hydraulic Project Approval and Section 401 Water Quality Certification, will be pursued for the Terminal once applications are filed and in coordination with the MAP Team.

For the Custer Spur improvements, BNSF Railway will pursue a Section 401 Water Quality Certification with Ecology.

### 2.1.4 Environmental Review Under NEPA and SEPA

The Major Project Permit (MPP) and other state and county permits and approvals will require environmental review under SEPA. Pacific International Terminals anticipates that an EIS will be prepared to provide this review. Through discussions with USACE, Pacific International Terminals understands that the USACE will prepare an EIS to evaluate the environmental impacts associated with the proposed Terminal and Custer Spur improvements and will retain an independent NEPA contractor to develop the EIS.

Because an EIS is anticipated under both SEPA and NEPA, it is expected that Whatcom County and the USACE will be co-leads and that a Joint NEPA/SEPA EIS will be prepared that complies with requirements under both sets of regulations. Both SEPA and NEPA require public notice, public participation, and an opportunity to review and comment on a Draft EIS. It is expected that these activities will be combined and conducted jointly between the USACE and Whatcom County.

### **2.1.5 Process to Coordinate Permitting among Agencies**

As shown in Tables 2-1 and 2-2, a number of agencies retain jurisdiction over various elements of the proposed project. After significant discussion with relevant federal, state, and local regulatory agencies and the Governor's Office of Regulatory Assistance (ORA), it was agreed that the permitting process for the Terminal would benefit from the coordination and collaboration offered by the legislatively authorized Multi-agency Permitting (MAP) Team process overseen and administered by ORA. With the agreement of all the parties involved, a MAP Team has been designated and organized to complete the permitting process for the Terminal project.

The purposes of the MAP Team are to:

- Address environmental regulatory and permit issues specific to the project.
- Provide early project review, including pre-application meetings.
- Provide interagency coordinated reviews.
- Provide regulatory and technical project comments according to a predictable schedule.
- Be a consistent review body for the project at all jurisdictional levels.

The MAP Team includes staff from Whatcom County, WDFW, WDNR, Ecology, USACE, the National Oceanic and Atmospheric Administration (NOAA), Northwest Clean Air Agency, local Tribes, and staff from the ORA. The MAP Team also includes technology staff providing internet-based document control and team-communication management tools.

Pacific International Terminals and BNSF anticipate securing the required permits through individual JARPA submittals respectively for the Terminal and Custer Spur improvements. BNSF Railway will directly coordinate its permitting efforts for the Custer Spur improvements with the appropriate agencies and in a manner consistent with current federal and state requirements and agreements.

## **2.2 TRIBAL CONSULTATION AND COORDINATION**

The USACE has been leading government-to-government consultation for the project, as directed by Section 106 of the National Historic Preservation Act (NHPA), since 2009. Project description letters

and vicinity maps have been sent to affected Native American Tribes, including the Lummi Nation and Nooksack Tribe. Tribal consultations on usual and accustomed fishing areas around Cherry Point, and cultural resources in the uplands, are ongoing and will continue as part of consultation under the NEPA and SEPA process.





## **CHAPTER 3 PURPOSE AND NEED**

Chapter 3 describes Pacific International Terminals' objective in developing the Gateway Pacific Terminal, including the purpose and the need for the proposed project.

### **3.1 PURPOSE OF THE PROPOSED ACTION**

The purpose of the proposed Gateway Pacific Terminal project is:

To develop and successfully operate a multimodal marine terminal, including a deep-draft wharf with access trestle and other associated upland facilities, for export and import of multiple dry bulk commodities ("multimodal deep-water bulk terminal") within the Cherry Point Industrial UGA to meet international and domestic demand. Development and operation of this Terminal further Pacific International Terminals, Inc.'s, business interests as an international, multimodal terminal developer and operator.

While achieving its purpose for Pacific International Terminals, the Gateway Pacific Terminal would further advance the economic development and environmental protection goals of the Whatcom County Comprehensive Plan's Cherry Point Industrial UGA and the Washington Department of Natural Resources designated Cherry Point Aquatic Reserve.

### **3.2 PACIFIC INTERNATIONAL TERMINALS, INC.'S, STATEMENT OF NEED**

The proposed project would meet three principal needs, each of which provides a basis for the proposed project:

1. The need to ship bulk cargo to and from Asia and other markets to meet current and future market demand;
2. The need for deepwater, bulk marine terminals in the Puget Sound region; and
3. The need for community and economic development in Whatcom County consistent with the Whatcom County Comprehensive Plan for the Cherry Point Industrial UGA.

To ensure a reasonable level of success, Pacific International Terminals needs to develop the project in a manner that responds to existing and future market demands and economic development opportunities, based on commercially efficient and effective design and operation of the Terminal, while taking appropriate measures to minimize adverse impacts on the environment.

#### **3.2.1 The Need to Ship Bulk Commodities to and from International Markets**

The Pacific Rim markets currently need a number of commodities that the US can export, including but not limited to coal, industrial minerals, aggregates, ores, wood products, and grains (see

Chapter 4 for a list of potential commodities that would be handled at the Terminal). The current and forecasted Pacific Rim demand for these commodities has been widely documented (International Monetary Fund 2010; Leow and Salamat 2010).

Forecasted growth in trade strains the capacity at US ports, particularly on the West Coast, which provides access to Pacific Rim countries. Asia represents the largest demand for commodities in the Pacific Rim region, especially China, India, Japan, and South Korea. This region includes the world's second and third largest economies in China and Japan (Barboza 2010). Estimates predict that Asia will account for 61 percent of the growth in global demand for commodities over the 15-year period from 2001 to 2015 (Griswold 2007; Park 2004). Gross domestic product for Asia as a whole was projected to grow by about 8 percent in 2010 and by at least 7 percent in 2011, with the economies of China, India, Japan, Taiwan, and South Korea leading the way (International Monetary Fund 2010). Economic growth and improvement in the quality of life and life expectancy in Asia and across the region have created large demands for a wide range of commodities, and the demand is predicted to remain high for the long term (Leow and Salamat 2010).

The Gateway Pacific Terminal will help meet the current and expected future demand for specific commodities and for handling increased shipping trade that requires a multimodal, deep-water marine terminal.

### **3.2.2 The Need for a Multimodal Deep-Water Bulk Marine Terminal in the Puget Sound Region**

Because of their physical nature (large quantities of voluminous, dry materials), dry bulk commodities are shipped in bulk rather than as containerized cargo. Bulk commodity cargo generally requires large ships with deep drafts. The use of large vessels allows bulk commodities to be transported more efficiently at lower cost per ton than smaller vessels would allow. The use of larger vessels also results in reduced traffic in ports and on constrained waterways.

The average size of vessels calling at US ports is growing steadily. As a result, by 2000 more than one quarter of the vessel calls to ports in the US were constrained by channel and port depths (USACE 2008). The US Maritime Administration has determined that the average size of vessels has increased as vessels have been replaced in recent years. In 2008, the average size of bulk carriers had increased 11 percent over the previous 5 years. This increase reflects the deployment of Capesize vessels into the international bulk carrier fleet. The large dimensions and deep drafts of these vessels mean that only large, deep-water terminals are capable of receiving these vessels (USACE 2008).

On the West Coast of North America, Prince Rupert, Vancouver, DeltaPort, Cherry Point, Seattle, Tacoma, and Los Angeles/Long Beach are the only locations where navigation channels with sufficiently deep drafts (greater than 50-foot depth) are available to accommodate these vessels (Ausenco Sandwell 2010a). Of those seven locations, three are located in the Pacific Northwest region of the United States. Two of these locations, Seattle and Tacoma, are already developed as ports. The Cherry Point Industrial UGA is a third location in the Pacific Northwest with the natural physical attributes to accommodate deep-draft vessels.

Over the past few decades, the demand for container terminals has also increased. As a result, most large ports in the Puget Sound region and along the West Coast with deep-water access are located in urban centers and have upgraded existing container terminals, or plan to develop new container terminals rather than deep-water bulk terminals.<sup>1</sup> Because container terminals occupy and are expected to continue to occupy ports with deep-water access and the substantial adjacent uplands suitable for marine terminals, the need for multimodal, deep-water bulk marine terminals is not being met in the Pacific Northwest region. No bulk marine terminal development projects are currently planned in the Puget Sound region. Moreover, ports on the Columbia River are limited by the 42-foot depth of the dredged navigation channel, and as a result can serve only smaller vessel sizes (light-loaded Panamax). Further, the Columbia River ports have been and will continue to be dependent upon continuous dredging to maintain terminal depths.

The proposed Gateway Pacific Terminal would help meet the need for deep-water bulk marine terminals that have the ability to effectively and efficiently transfer cargo between overland and waterborne modes of transport in the Puget Sound region.

### **3.2.3 The Need for Community and Economic Development**

Both the US Government and Washington State have adopted policies and commenced initiatives to expand interstate commerce and export trade. The proposed project would help to implement both the *President's National Export Initiative* (Office of the President 2010) and the Governor's 6-Point Export Plan (Office of the Governor 2010).

The objective of the President's initiative is to double American exports over the next 5 years, starting in 2010. A critical component of stimulating economic growth in the US is ensuring that businesses can actively participate in international markets by increasing their export of goods, services, and agricultural products. The State of Washington has likewise taken steps to increase the number of Washington state companies exporting goods and services and thereby help increase exports from

---

<sup>1</sup> See, for example, Port of Seattle's Harbor Development Strategy for Marine Cargo and Container Terminal Development Plan, and similar plans from other ports and harbors, including the Ports of Los Angeles, Long Beach, Oakland, and Tacoma.

the state by 30 percent by 2015 (Office of the Governor 2010). Washington State's 6-point export plan was designed to generate economic growth by expanding opportunities for exporters. The 6-point plan aims to enhance the state's ability to move goods efficiently by supporting investments in infrastructure.

The US Department of Transportation's (USDOT) Maritime Administration determined that marine terminals are an essential link between US and foreign commerce and between waterborne transport and overland modes of transport, which together deliver goods to businesses and consumers (USACE 2008). The USDOT Maritime Administration also determined that port development and growth through increased capacity, increased efficiency, and technological improvement are crucial to support the national economy (IHS Global Insight 2009).

At the local level, Whatcom County has reiterated the need for economic and community development. The most recent update to the Whatcom County Comprehensive Plan (Plan) calls for continued development of the Cherry Point Industrial UGA (Whatcom County 2010). The Comprehensive Plan is based on many years of studies, planning, and agreements among federal, Tribal, regional, state, and local governments and interested businesses, citizens, and the community. The Plan identifies the need for natural resource industries and the potential for the Cherry Point Industrial UGA to meet this need. The County's Shoreline Master Program designates the Terminal project area as part of the Cherry Point Management Area, and specifically allows port and water-dependent uses.

The Terminal is consistent with the goals of the WDNR's Cherry Point Aquatic Reserve designation for the area and with the Reserve's Management Plan (WDNR 2010), which specifically allows this proposed development.

This project furthers state and national policies regarding international trade and economic development. The project also helps meet the economic development and other needs identified in the Whatcom County Comprehensive Plan to continue to develop the Cherry Point Industrial UGA, specifically with a multimodal, deep-water bulk marine terminal.

### **3.2.4 The Need for an Appropriate Site**

The commercial success of the project requires a site that is strategically located to respond to existing and future market demands and economic opportunities. The site must also possess unique features and characteristics to ensure efficient and cost-effective Terminal operations. Specifically, to maximize annual throughput of commodities and to achieve the economies of scale necessary to ship low to medium value bulk commodities to international markets profitably, large trains and ships are required. A deep-draft wharf is necessary to accommodate the Panamax and Capesize vessels that

currently service the commodity fleet and allow these vessels to be safely loaded or unloaded (US Maritime Administration 2009a). Since operation of these large, oceangoing vessels is the most costly part of transporting bulk commodities, the time that each vessel spends at dock must be kept to a minimum. To achieve this operating efficiency, the Terminal must have sufficient land area, rail capacity, and ancillary infrastructure to marshal large quantities of bulk cargo quickly to or from a vessel. A large land area is needed to provide sufficient space to effectively unload and store cargo.

To meet these needs, Pacific International Terminals requires a property that:

- Is located on the West Coast of the US;
- Is of sufficient size to effectively accommodate the handling and storage of large quantities of dry bulk commodities;
- Is appropriately designated and zoned for use as a marine terminal;
- Can support a deep-water marine terminal and wharf;
- Has proximity and access to rail of sufficient length, configuration, and capacity to support the proposed use;
- Has proximity and access to major roads; and
- Has a sufficient supply of industrial water and energy.

The proposed Gateway Pacific Terminal project area meets all these criteria. The project area is strategically located and has been zoned, designated, and permitted for development as a marine terminal. The project location can accommodate the deep draft vessels required for the successful operation of the Terminal without any development or maintenance dredging.

The upland commodities handling and storage facilities are of sufficient capacity to stockpile, consistent with industry standards, on the order of 6 to 8 percent of annual throughput. The storage and handling facilities have also been designed to accommodate a complete high-capacity train within designated rail loops at the Terminal site.

To avoid interference with main line rail traffic, the Terminal is designed to accommodate trains up to 8,500 feet long within the project area. To promote efficient train handling, tracks are designed in a loop to maximize rail access and minimize area used. A rail loop of this size creates a large interior space well suited to material storage in stockpiles. The stockpile capacity required is proportional to annual throughput, since sufficient storage space must be available to efficiently handle cargo unloaded from trains and loaded into vessels. For the East Loop, the recommended percentage of annual throughput would be approximately 2.9 million metric tons, which is consistent with the

designed stockyard capacity for that area (approximately 2.75 million metric tons). Handling of different commodities requires that the commodities be segregated. Therefore, separate storage and handling areas within the facility are required and would be accommodated with the Terminal design. Finally, the project location provides ready access to key transportation arteries and industrial water and energy sources used by existing industries.

## **CHAPTER 4 THE PROPOSED ACTION**

This chapter presents a detailed description of the proposed action to construct and operate the Gateway Pacific Terminal. This project description is intended for consideration by agencies with jurisdiction during the environmental review and permitting process and to provide information to other stakeholders and interested parties.

### **4.1 PROJECT OVERVIEW**

The Gateway Pacific Terminal will be a multimodal, deep-water Terminal to provide storage and handling for the export and import of dry bulk commodities. The Terminal would be developed on approximately 350 acres within a total project area of 1,200 acres (Figure 1-2). The project area is zoned for Heavy Impact Industrial use and is located in Whatcom County's Cherry Point Industrial Urban Growth Area. The Terminal would be designed to minimize impacts to associated resources while meeting the purpose and need for the project.

Terminal construction would be completed in two development stages. Construction of Stage 1 is expected to commence in 2013 when all required federal, state, and local permits and authorizations have been obtained and environmental review under NEPA and SEPA has been completed. Pacific International Terminals currently anticipates that Stage 1 will be completed by 2015 and Stage 2 by 2017 (see Section 4.4).

The Terminal would be designed to handle up to 54 million metric tons per year of dry bulk commodities. Commodities would be transferred to and from the Terminal by rail on the BNSF Railway's Custer Spur. Modern material handling equipment would be installed and effective practices would be implemented to protect the safety of Terminal employees and protect the environment during Terminal operations.

The type and quantity of dry bulk commodities managed during the operating life of the Terminal would likely change over time depending upon customer and market demands. The Terminal's commodities storage and handling infrastructure would enable the Terminal to handle the export and import of a wide range of commodities, including grain products, coal, potash, calcined petroleum coke, and other bulk commodities. It is anticipated that the Terminal would initially manage export of calcined petroleum coke and potash from the west loop storage area and low-sulfur, low-ash coal and other coal products from the east loop storage area.

### **4.2 PROPERTY OWNERSHIP**

Approximately 1,109 acres of the approximately 1,200-acre project area is land owned by Pacific International Terminals. The project area also includes Whatcom County road rights-of-way, state-

owned tidelands, and a small parcel of land owned separately (Table 4-1; Figure 1-3). In addition, a number of utility easements cross the project area. Major portions of the trestle and wharf would be located on state lands leased from the Washington Department of Natural Resources.

**Table 4–1 Summary of Land Ownership and Acreage in the Project Area**

<b>Land Owner</b>	<b>Upland (acres)</b>	<b>Marine (acres)</b>	<b>Total (acres)</b>
Pacific International Terminals, Inc.	1,090.5	18.2	1,108.7
Whatcom County rights-of-way	19.9	0.0	19.9
Parcel 14	29.6	0.0	29.6
State lands managed by Department of Natural Resources	0.0	43.3	43.3
<b>Total</b>	<b>1,140.0</b>	<b>61.5</b>	<b>1,201.5</b>

BNSF Railway would provide rail service via the Custer Spur, the only existing rail line serving the Cherry Point industrial UGA. The Custer Spur branches west from the BNSF Railway’s Bellingham Subdivision main line at Custer, then travels west, then south approximately 6.2 miles. The width of the BNSF Railway’s existing right-of-way ranges from 70 feet to over 150 feet. BNSF Railway expects to acquire approximately 43 additional acres of contiguous rights-of-way adjacent to its currently owned rights-of-way. The additional rights-of-way would be used for rail improvements required to support the Terminal and for compensatory mitigation. The estimated area of acquisition is based on an average 40-foot linear embankment along the Custer Spur, additional width for an access road parallel to the Spur between Ham Road (BNSF Railway Milepost 1.86) and Brown Road (BNSF Railway Milepost 4.95), and extra width for construction of additional receiving and departure trackage.

### **4.3 THE PROPOSED PROJECT**

As a deep-water, multimodal marine terminal for the export and import of dry bulk commodities, the Terminal has been designed to meet the operational needs of Pacific International Terminals and to successfully service dynamic international bulk commodity markets over the long term. The Terminal design provides maximum flexibility to handle a wide range of commodities as market needs and customer demands change over time. The deep-draft wharf and storage and handling areas allow the Terminal to load large, oceangoing vessels efficiently for shipment of commodities to Asian and other international markets.

Because the Terminal would handle a broad range of dry bulk commodities during its functional life, it will be designed so that only minor changes in infrastructure would be required to accommodate different commodities, or to change from export to import. As discussed in Section 3.2.4, for successful operation, a large land area is needed to provide sufficient space to store cargo



temporarily at the Terminal and to support the required rail infrastructure. In addition, a deep-draft wharf is necessary to accommodate the large Panamax and Capesize vessels that currently service the import/export commodity trade.

For safe and effective operation, the Terminal requires extensive infrastructure and facilities, including:

- Two independently operational, industrial service rail loops (the “East Loop” and “West Loop”) with sufficient trackage to handle projected bulk volumes by rail; both loops would be connected to BNSF Railway’s Custer Spur, and each loop would house associated commodity storage capacity, material handling equipment, and other required bulk handling infrastructure;
- A Shared Services Area providing access from the East and West Loops to the access trestle and wharf;
- A three-berth, deep-draft wharf with ship-loading equipment and an access trestle extending from the shoreline to the wharf;
- Stormwater management systems and other utilities;
- Specific design features to avoid, minimize, or compensate for the environmental effects of the Terminal; and,
- Improvements to the existing BNSF Railway’s Custer Spur, including rail receiving/departing infrastructure and, eventually, a double track from the Custer Wye to the proposed Terminal.

The project layout and the locations of these general functional areas are shown in Figure 1-2.

### **4.3.1 East Loop**

The Gateway Pacific Terminal East Loop would handle a wide variety of dry bulk commodities in its lifetime. Initially, it is anticipated that the East Loop would predominantly handle low-sulfur, low-ash coal.

The general layout of the East Loop is shown in Figure 4-1. The East Loop would include the following facilities:

- Service rail loop and unloading station;
- 80-acre stockyard and associated machinery, including stacking and reclaiming machines;
- Approximately 8,000 square feet of new buildings;
- Conveyors for outloading and inloading commodities; and

- Access roadways.

The East Loop would also include development of utilities, such as stormwater treatment facilities, electrical power, lighting, water, communications, and wastewater facilities. Features that are common throughout the Terminal are described in Sections 4.3.6 through 4.3.8.

#### **4.3.1.1 East Loop Rail and Unloading Station**

Rail access to the East Loop would be provided from the Custer Spur. A new multiple-switch connection and new connecting trackage would join the Custer Spur just north of BNSF Railway's existing Elliot Rail Yard, located between Aldergrove Road and Lonseth Road (Section 4.3.5). The East Loop would be designed to allow unobstructed unloading of rail cars. The loop would also support staging of both loaded, inbound bulk commodity trains preparing for dumping, and empty, outbound trains being inspected for departure. When developed to its full capacity, the East Loop rail facilities would be capable of accommodating multi-train dumping of bulk commodities, with capacity to stage up to eight trains for either inbound or outbound Terminal movements. The rail would be built on an engineered embankment to provide a level rail surface, thereby minimizing fuel consumption and improving rail operations and safety.

The East Loop would include a commodities unloading station incorporating appropriate dust controls. The station would house a single unloading shed employing a tandem rotary dumper to unload two gondola-style railway cars into a dumper pit simultaneously. The shed at the unloading station would allow commodities to be unloaded within a covered structure. At full buildout, the East Loop would house a second unloading station with a second shed to allow two trains to be unloaded simultaneously.

The proposed unloading stations would be built over a conveyor that moves the delivered commodity to the stockyard. This conveyor would also be covered and operated to control dust during cargo transfer operations. A certified scale would be integrated into the rail bed to determine the amount of commodities delivered or loaded.

To support rail-loading operations for import of commodities, a loading facility could be added to the rail loop, and the proposed outloading conveyor systems could be replaced with conveyors that feed instead to a train-loading station from the stockpiles. If a different commodity were to be handled at the East Loop, the unloading station would be modified to handle the type of rail cars used for that commodity. The remaining infrastructure would remain largely the same to manage any other bulk commodity..

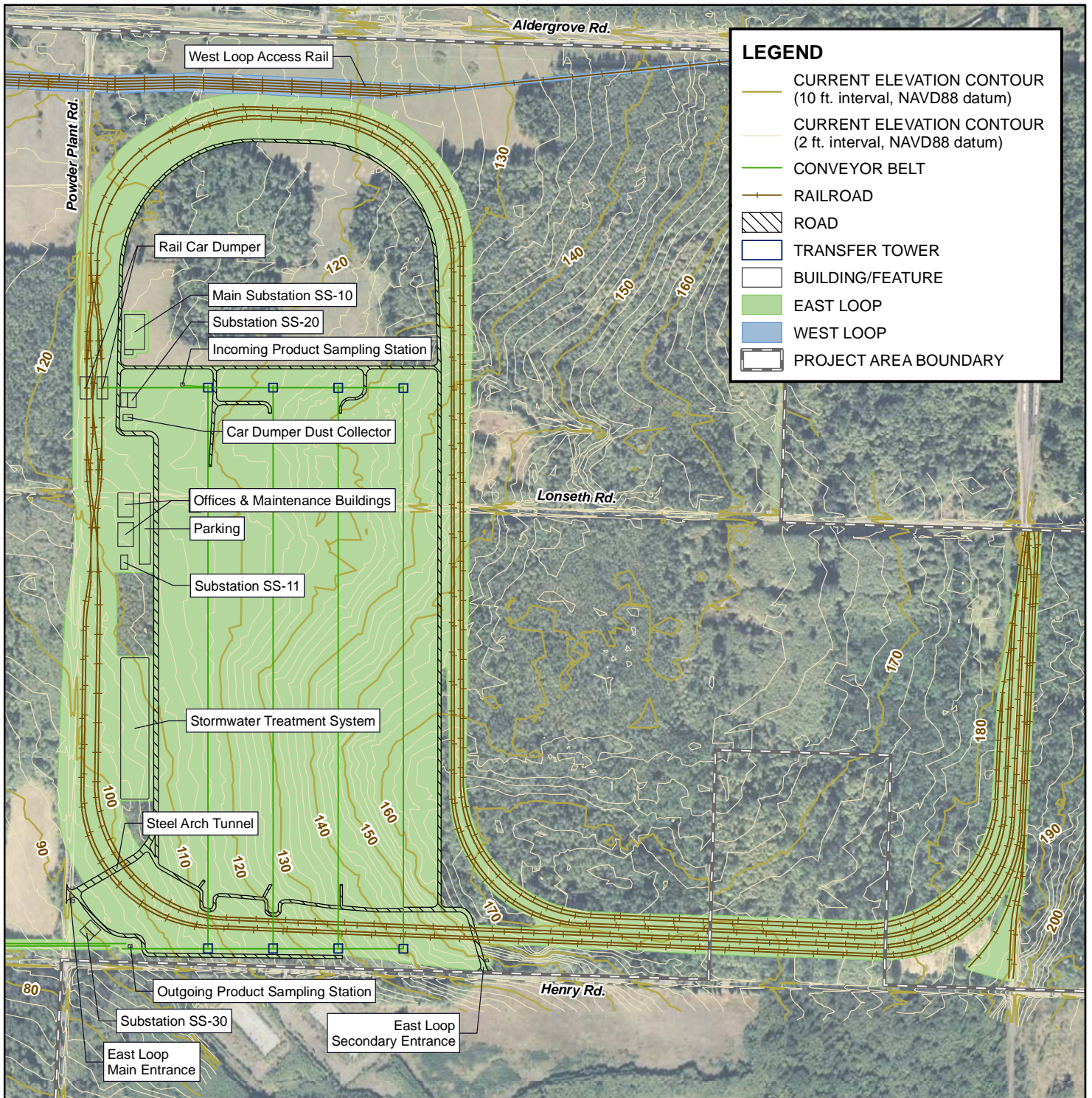

Source:  
 Ausenco Sandwell, 154199-A100-42S01.dwg (Rev. J), 12/24/2010.  
 David Evans & Associates, 2010-04-14-svTPXpiti0006-DEGROSS.dwg,  
 07/20/2010.

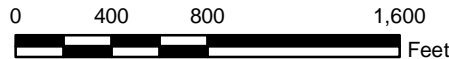

				CLIENT: <b>PACIFIC INTERNATIONAL          TERMINALS, INC.</b>	
PROJECT: <b>PROPOSED GATEWAY PACIFIC TERMINAL</b>		DWN BY: SD	DATUM: NAD83	DATE: FEBRUARY 2011	
TITLE: <b>EAST LOOP</b>		CHK'D BY: KD	REV. NO.: 1	PROJECT NO.: 091515338C-18-01	
		PROJECTION: WA SP North, Ft.	SCALE: 1 inch=800 feet	FIGURE No.: <b>FIGURE 4-1</b>	



### **4.3.1.2 East Loop Stockyard and Material Handling Equipment**

The East Loop would include infrastructure required for handling dry bulk commodities. For coal, these would include a single large, open-air stockyard serviced by stacking and reclaiming machines (called “stacker/reclaimers”) and outloading/inloading conveyor lines with surge bins. The stockyard would be created on a “patio”—an approximately 80-acre, unpaved, level area with gravel-surfaced lanes between commodity stockpiles. If commodities were stored in continuous piles, the total capacity of the stockyard would be approximately 2.75 million metric tons. Initially, two stacker/reclaimers would service three stockpiles (approximately 1.25 million metric tons). At maximum capacity, the East Loop stockyard would have the capacity for five stockpiles, managed with four stacker/reclaimer lines. Stockpiles would be approximately 2,500 feet long and up to about 62 feet high; the stacker/reclaimers would be approximately 115 feet high. The rail-mounted stacker/reclaimers would move along the lanes between stockpiles to service the stockpiles. Commodities would be stockpiled by the stacker/reclaimers.

### **4.3.1.3 East Loop Conveyors**

The East Loop would have multiple belt conveyor lines connected at transfer towers to move materials from one location to another (Figure 4-2). A transfer conveyor would move material from the unloading station to the infeed transfer conveyor. The infeed transfer conveyor would connect at a transfer tower to one of the four stockyard conveyor lines. These stockyard conveyors would in turn feed materials to the stacker/reclaimers that service the stockpiles.

From the stacker/reclaimers, separate conveyors would move material to other transfer towers that connect to the outfeed transfer conveyor line. The outfeed conveyor would move material from the stockpiles to a surge bin that regulates the flow of material onto the shipping conveyor line. Lying outside the East Loop, the shipping conveyor would move material out of the East Loop to conveyors in the Shared Services Area, and subsequently to a final set of conveyors on top of the trestle serving shiploaders at the wharf.

Figure 4-2 shows a typical conveyor gallery and a cross section of the conveyor housing. All conveyors used for materials handling at the Terminal would be constructed with covers to control dust (Figure 4-3). The conveyor belts would be driven by electric motors. Transfer points between conveyor belts at transfer towers and at the surge bin would be equipped with passive enclosure dust control systems, including staggered conveyor curtains and covered chuting.

### **4.3.1.4 East Loop Service Buildings**

The East Loop would have four buildings: a maintenance building (3,900 square feet), a single-story administration building that includes changing facilities (4,500 square feet), and two security gatehouses (250 square feet each).

The maintenance building would be an industrial-style, slab-on-grade, structural steel building with a painted, corrugated steel roof. The administration/changing facility would be a modular building with painted steel roof. A paved parking area with lighting would be located adjacent to these buildings. While the maintenance building is currently planned as a separate structure, it could be combined with the common administration/changing facility into a single structure with the same approximate total square footage.

#### **4.3.1.5 Access Roadways**

A new paved road would be constructed to provide primary access to the East Loop (Figure 4-1). The paved access road would connect near the intersection of Gulf and Henry Roads and would be considered the Terminal's main entrance. Other East Loop roads, including a loop road paralleling the rail tracks, would be paved and would provide access to the stockyard patio and other facilities. Approximately 4 miles of roads would be built within the East Loop. The new roads would be 18 feet wide with 4-foot shoulders on both sides.

Near the main entrance, a steel-arch tunnel conveying the access road beneath the rail bed embankment would be provided to allow unobstructed access to the East Loop at all times, including when the rail lines are in use. The structure would have a span of 28 feet, an interior height of 17 feet, and a length of 50 feet from headwall to headwall. To serve as a secondary access point, an at-grade crossing connecting to Henry Road would be located at the southeast corner of the East Rail Loop. This access point would be blocked approximately 50 percent of the time at full buildout due to the presence of trains.

#### **4.3.2 West Loop**

The Gateway Pacific Terminal West Loop would be designed to handle multiple types of dry bulk commodities. Similar to the East Loop, the West Loop would be designed so that changes in types of commodities or a change from export to import operation would require only minor changes in infrastructure. The West Loop is initially planned to handle export of calcined petroleum coke and potash. The West Loop would provide rail infrastructure and covered bulk commodity storage areas. The area would include stacking and reclaiming conveyors, an unloading station, and outloading/inloading conveyor lines.

The West Loop would house the following features (Figure 4-4):

- Rail loop and unloading station;
- 752,500 square foot storage area and associated machinery;

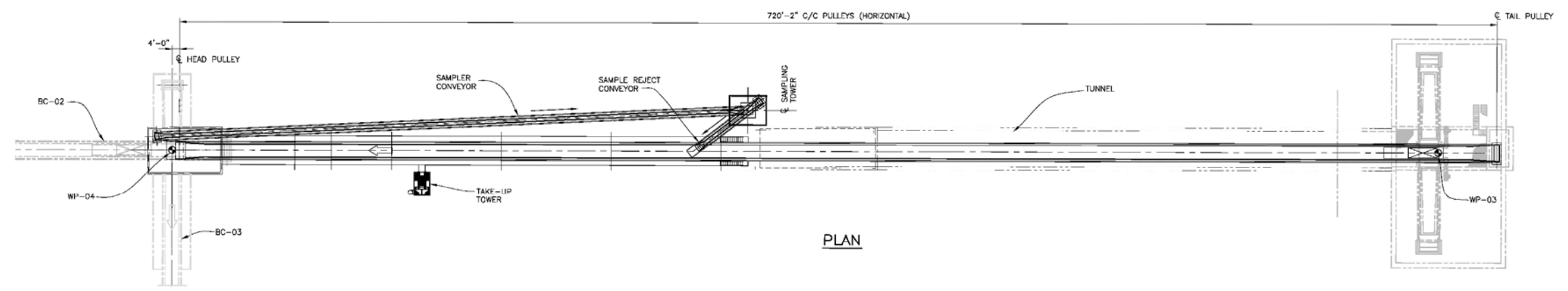

PLAN

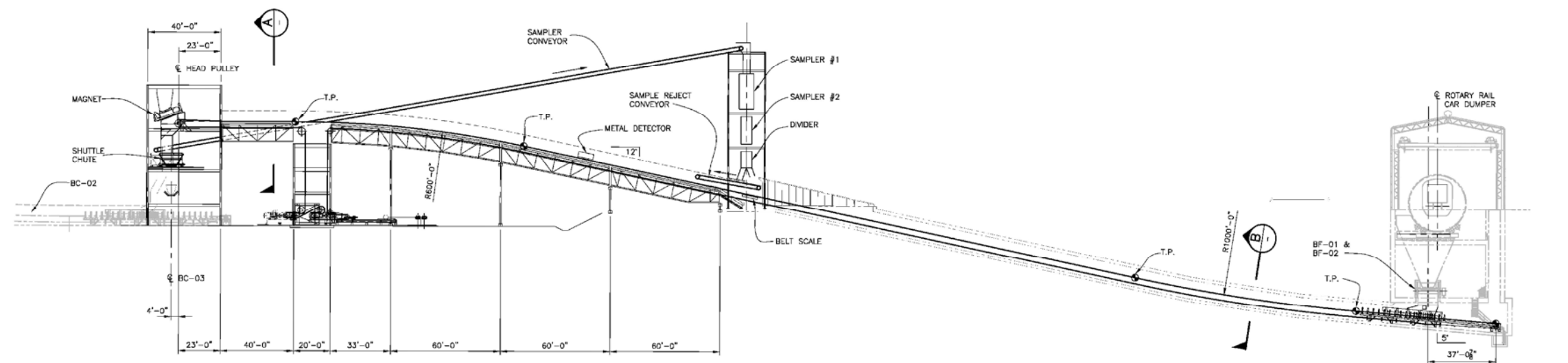

ELEVATION

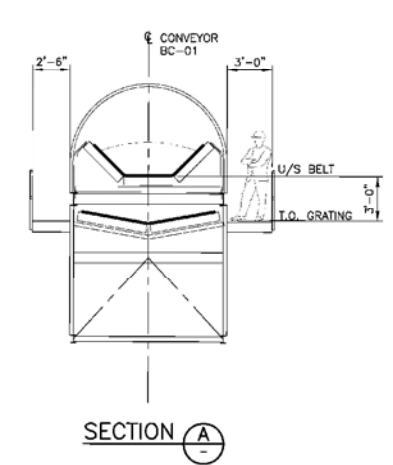

SECTION A

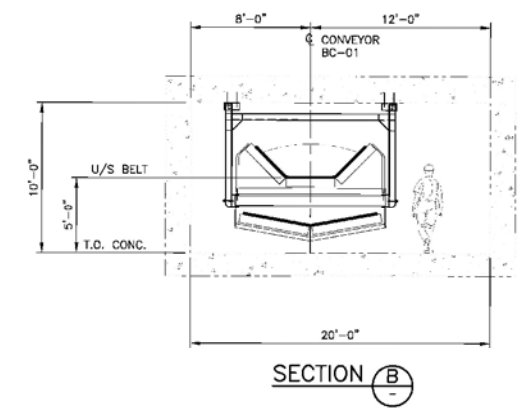

SECTION B

Source:  
Ausenco Sandwell, 154199-A400-42050.dwg (Rev. B), 05/21/2010.



CLIENT:  
**PACIFIC INTERNATIONAL TERMINALS**

DWN BY: SD  
CHK'D BY: KD  
DATUM: -  
PROJECTION: -  
SCALE: NOT TO SCALE

PROJECT:  
**GATEWAY PACIFIC TERMINAL**

TITLE:  
**EXAMPLE CONVEYOR CROSS-SECTION**

DATE:  
FEBRUARY 2011  
PROJECT NO.:  
091515338C-18-01  
REV. NO.:  
1  
FIGURE NO.:  
FIGURE 4-2







Source:  
Pacific International Terminals, Inc.



CLIENT:  
**PACIFIC INTERNATIONAL TERMINALS, INC.**

DWN BY: SD  
 CHK'D BY: KD  
 DATUM: -  
 PROJECTION: -  
 SCALE: -

PROJECT:  
**PROPOSED GATEWAY PACIFIC TERMINAL**

TITLE:  
**EXAMPLE OF COVERED CONVEYOR**

DATE:  
FEBRUARY 2011  
 PROJECT NO.:  
091515338C-18-01  
 REV. NO.:  
-  
 FIGURE NO.:  
FIGURE 4-3



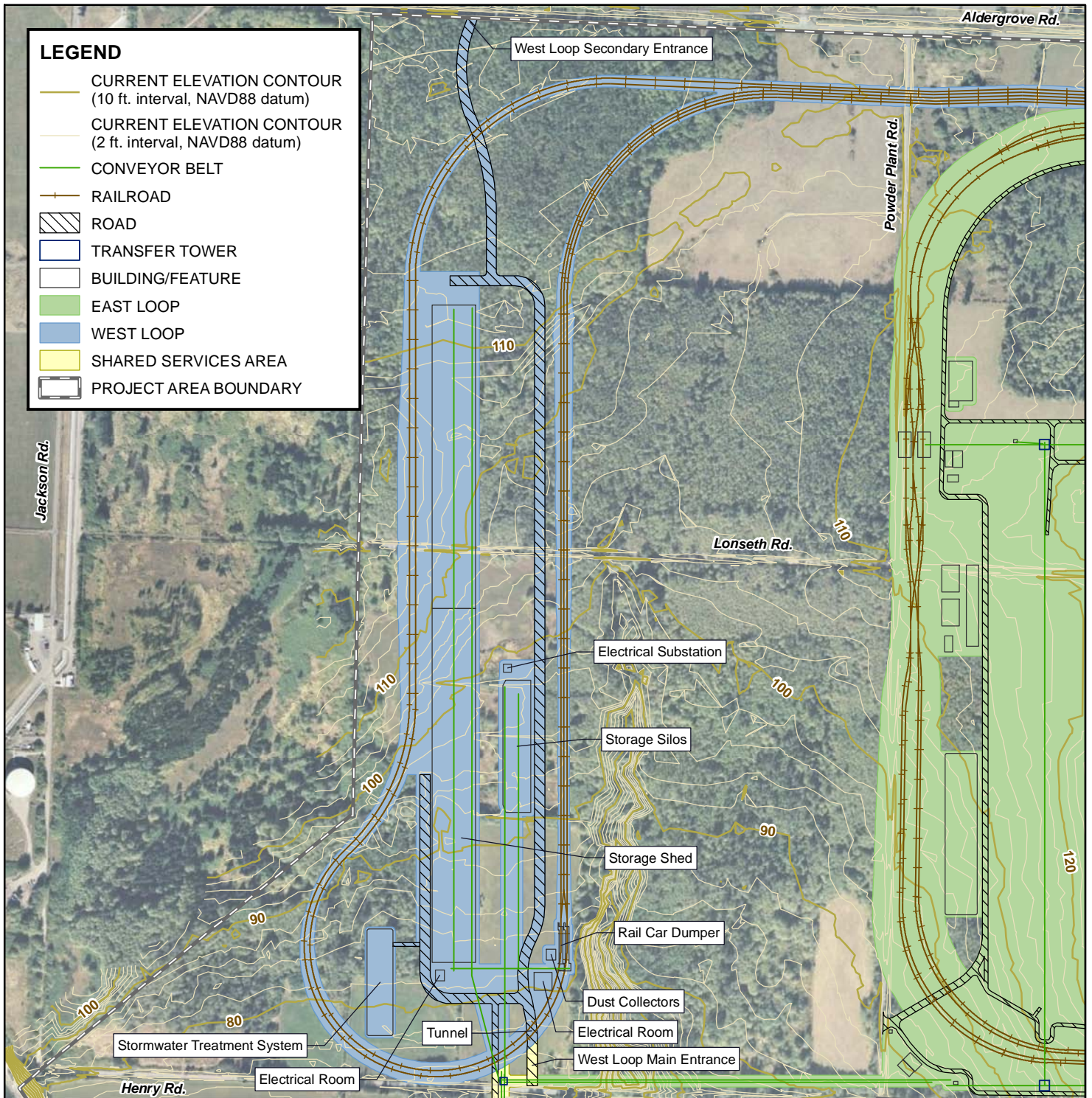

Source:  
 Ausenco Sandwell, 154199-A100-42S01.dwg (Rev. J), 12/24/2010.  
 David Evans & Associates, 2010-04-14-14-svTPXpiti0006-DEGROSS.dwg,  
 07/20/2010.

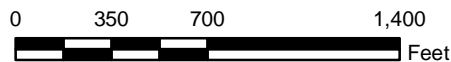

				CLIENT: <b>PACIFIC INTERNATIONAL          TERMINALS, INC.</b>	
PROJECT: <b>PROPOSED GATEWAY PACIFIC TERMINAL</b>		DWN BY: SD	DATUM: NAD83	DATE: FEBRUARY 2011	
TITLE: <b>WEST LOOP</b>		CHK'D BY: KD	REV. NO.: 1	PROJECT NO.: 091515338C-18-01	
		PROJECTION: WA SP North, Ft.	SCALE: 1 inch=700 feet	FIGURE No.: <b>FIGURE 4-4</b>	



- Conveyors and conveyor lines; and
- Access roadways.

Development of the West Loop would also include electrical power, water, stormwater, lighting, communications, and wastewater facilities. These features are described in Sections 4.3.6 through 4.3.8.

#### **4.3.2.1 West Loop Rail and Unloading Station**

Rail access to the West Loop would branch from the Custer Spur from BNSF Railway's BP lead (also called ARCO lead) via a new switch just north of Aldergrove Road. The switch would be located approximately 4,000 feet east of Powder Plant Road (Figure 1-2). From this new switch, the West Loop track would cross Aldergrove Road diagonally with a barrier-style, at-grade crossing and extend westward, running parallel to Aldergrove Road and avoiding an existing utility corridor.

The West Loop rail infrastructure would provide two inbound and two outbound tracks leading to the rail unloading station, with a third track along the east side of the loop for empty trains leaving the Terminal. This proposed rail configuration would enable two trains to be filled or unloaded at the same time, while a third train is staged on site (Figure 4-4).

The rail infrastructure along the south end of the loop would be built on an engineered embankment, while the existing grade near and along Aldergrove Road would be cut and filled to provide level elevations at the rail unloading station.

The proposed unloading station would incorporate two bottom dumper systems to allow simultaneous unloading of up to four closed-top hopper rail cars carrying commodities such as potash (see Figure 4-4). The unloading station would be built on a concrete structure designed to support the trains on continuous welded rails. The working area of each of the bottom dumper systems would be protected by a shed with timber frame sidewalls and metal roofs, with the ends of the sheds left open. A conveyor in the receiving hopper below the dumper would move delivered materials to the storage shed. The unloading station would be equipped with dust control facilities. A certified scale would be integrated into the rail bed to determine the amount of commodity delivered or loaded.

If in the future trains were to be loaded rather than unloaded, a railcar loading facility could be added to the rail loop and the conveyors replaced to provide train-loading capability from the storage area.

#### **4.3.2.2 West Loop Storage and Material Handling Equipment**

Covered storage facilities are planned for the West Loop, assuming that potash and calcined petroleum coke would be initially handled in this area. Storage facilities to be constructed would

include a single A-frame potash storage shed with a total capacity of approximately 360,000 metric tons and six storage silos for calcined petroleum coke. The area would also be capable of housing other types of storage, such as grain silos, flat bottom sheds, or covered bins.

The A-frame potash storage shed would be supported by a concrete perimeter foundation, which also would form part of the shed's retaining walls. The shed would be constructed of laminated wood main beams with plywood walls and roof. The shed floor would be asphalt. Inside the ridgeline of the shed's roof, a gallery structure would support a conveyor, tripper, and soft drop chutes for moving materials into the structure. At the base of the walls and on top of the concrete retaining walls, a crane rail would support a portal-style reclaim machine to feed material onto a reclaim conveyor (Figure 4-5).

Six storage silos are currently anticipated for the storage of calcined petroleum coke at the West Loop (Figure 4-6). The cast-in-place silos would each have a capacity of 13,500 metric tons for a total storage capacity of 81,000 metric tons. Each silo would be approximately 100 feet in diameter and 180 feet tall and built on steel pilings with concrete foundations. The calcined coke would be delivered at the unloading station and fed onto a conveyor that moves the material into the top of each silo. The bottom of each silo would have a steel hopper system that opens to feed onto an out-loading conveyor that connects to the conveyors in the Shared Services Area. Both the in-loading and out-loading equipment would be covered and fitted with dust control systems.

#### **4.3.2.3 West Loop Conveyors**

In addition to the conveyors from the unloading station (Section 4.3.2.1), those operating inside the shed (Section 4.3.2.2), and those managing materials to and from the silos, covered transfer conveyors would move materials from the storage area to the Shared Services Area (Figure 4-4).

#### **4.3.2.4 West Loop Access Roadways**

A new paved road would be constructed to provide primary access to the West Loop from Henry Road. This location would be considered the main entrance for the West Loop (Figure 4-4). Other West Loop roads would include a paved road paralleling the length of the storage shed and continuing on to the secondary entrance on Aldergrove Road. The roadways would be approximately 18 feet wide with 4-foot shoulders on both sides. Approximately 2.8 miles of asphalt roadway would be built within the West Loop.

A concrete box tunnel would be constructed near the main entrance at Henry Road to convey the access road beneath the rail bed embankment, allowing unobstructed access to the East Loop at all times, including when the rail lines are in use. The structure would have a span of 15 feet, an interior height of 20 feet, and a length of 100 feet from headwall to headwall. To serve as a secondary access point, an at-grade crossing connecting to Aldergrove Road would be located at the northern

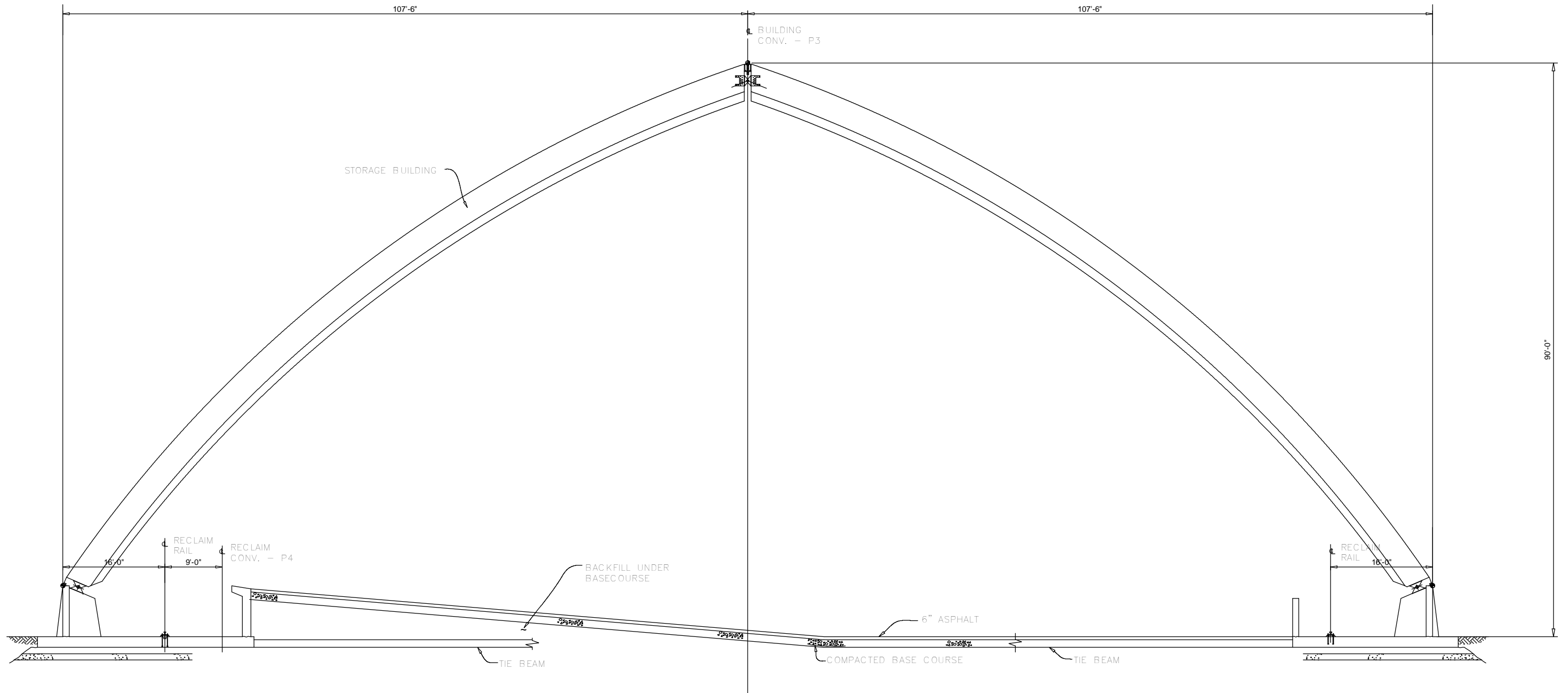

Source:  
Ausenco Sandwell, 154020-6003.dwg (Rev. P1), 08/21/2006.



CLIENT:  
**PACIFIC INTERNATIONAL TERMINALS, INC.**

DWN BY: SD  
CHK'D BY: KD  
DATUM: -  
PROJECTION: -  
SCALE: NOT TO SCALE

PROJECT:  
**PROPOSED GATEWAY PACIFIC TERMINAL**

TITLE:  
**EXAMPLE SHED DIMENSIONS**

DATE: FEBRUARY 2011  
PROJECT NO.: 091515338C-18-01  
REV. NO.: 1  
FIGURE NO.: FIGURE 4-5





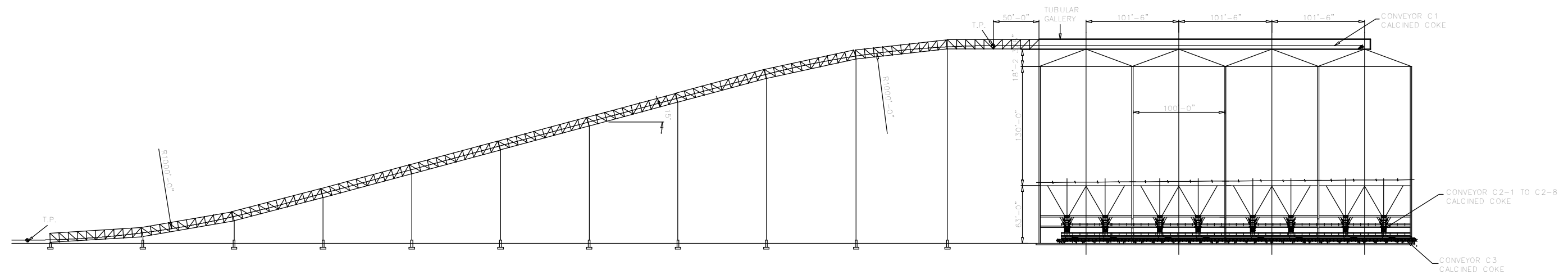

**NOTE:** Although drawing only shows 4 storage silos, 6 storage silos will actually be constructed.

ELEVATION  
SCALE: 1

Source: Ausenco Sandwell, 154020-2391.dwg (Rev. P1), 08/21/2006.	 <b>Pacific International Terminals</b> <small>A Carrix Enterprise</small>	CLIENT: <b>PACIFIC INTERNATIONAL TERMINALS</b>	DWN BY: SD	PROJECT: <b>GATEWAY PACIFIC TERMINAL</b>	DATE: <b>FEBRUARY 2011</b>
			CHK'D BY: KD		
			DATUM: -	TITLE: <b>EXAMPLE STORAGE SILOS</b>	REV. NO.: <b>1</b>
			PROJECTION: -		FIGURE NO.: <b>FIGURE 4-6</b>
			SCALE: NOT TO SCALE		



extent of the West Loop. When the Terminal is in full operation, this access point would be blocked approximately 20 to 30 percent of the time due to the presence of trains.

### **4.3.3 Shared Services Area**

The linear corridor that begins at Henry Road and extends to the abutment of the access trestle would be used as a Shared Services Area (Figure 4-7). The corridor would include an access roadway as well as conveyor lines running from the East and West Loops to the access trestle. The East Loop's shipping conveyor would terminate in the Shared Services Area, and the West Loop conveyor would deliver material to the north end of the Shared Services Area.

A service building, which would serve as a longshoreman's services and administration building, would be located next to the roadway. In addition, the Shared Services Area would include a water treatment plant next to the administration building to treat sanitary wastewater from the building, an electrical substation, and a parking area.

No rail access is planned for this area.

### **4.3.4 Wharf and Access Trestle**

Gateway Pacific Terminal would incorporate a three-berth, deep-draft wharf with ship loading equipment and an access trestle extending from the shoreline to the wharf (Figure 4-8).

The wharf and part of the access trestle would be built on state aquatic lands. The area proposed for construction of the wharf and trestle has been designated in the state's *Cherry Point Environmental Aquatic Reserve Management Plan* (WDNR 2010). The Shoreline Substantial Development Permit issued in 1997 by Whatcom County authorized the design and configuration for the wharf and trestle described here. As specified in that permit, the wharf would be 2,980 feet long and 105 feet wide, with access provided by a 1,100-foot-long, 50-foot-wide access trestle.

#### **4.3.4.1 Access Trestle**

The access trestle would begin at a constructed abutment inland of the shoreline bluff, cross above the bluff, and descend to the wharf (Figure 4-8). With this design, the trestle would cross over the water from above the bluff, which would remain largely undisturbed at its existing elevation. The trestle is designed to provide access to the wharf where the vessels berth; it will not have any docking facilities.

The trestle's 50-foot width would allow two vehicles to pass each other as one enters and one leaves the wharf. The side section is designed to accommodate two enclosed conveyor lines running parallel at deck height (see Figure 4-9). At full buildout, a third enclosed conveyor line would be added to

increase transfer capacity. The third conveyor would be either stacked above the other two or cantilevered off to the side (third conveyor not shown in figure). Trestle conveyors would be fully enclosed in a gallery. The design of the first two spans of the access trestle over the nearshore area will use steel deck grating to minimize shading in the intertidal zone.

#### **4.3.4.2 Wharf**

The wharf would be located at the trestle head and generally parallel to the shoreline; it would be designed to berth up to three vessels (Figure 4-9). The wharf would have one berth southeast of the trestle head and two berths to the northwest of the trestle head.

The wharf would have three berths, each of different lengths (Figure 4-8):

- Berth 1—1,137 feet long
- Berth 2—1,227 feet long, and
- Berth 3—636 feet long

Berth 1 is the northwestern-most berth.

The wharf would support up to three shiploaders, belt conveyors in an enclosed elevated gallery leading to each of the shiploaders, berthing fenders, and a vessel-mooring system. The wharf would be sufficiently wide to allow two lanes of vehicle access beneath the legs of the shiploaders. The elevated gallery would be located on the shore side of the wharf behind the shiploaders. The wharf would include containment for control of potentially contaminated stormwater. Uncontaminated stormwater runoff from the wharf and trestle would be discharged to the water.

Shiploaders are machines specifically designed to fill the holds of vessels with bulk commodities (Figure 4-10). Material travels on enclosed conveyor belts to the shiploader, where it is fed on a boom onto the ship and into the hold. The shiploader travels the length of the berth on rails and the boom moves up, down, inward, outward, and side-to-side to fill the vessel's hold completely and evenly while accommodating changing vessel heights from tidal change. The material discharges at the end of the boom through a chute that is designed specifically to reduce dust generation by containing the product flow into a tight stream. In addition, the shiploader would be equipped with a dust suppression system to minimize fugitive dust from both the transfer of the commodity from the wharf conveyor to the shiploader and at the discharge at the end of the boom.

The wharf's mooring configuration would meet Puget Sound Pilots' standards for berthing, with three headlines, two breast lines, and two backsprings fore and aft on standard bollards for each berth. Each of the three berths would have embedded junction boxes and conduits for future "cold ironing"

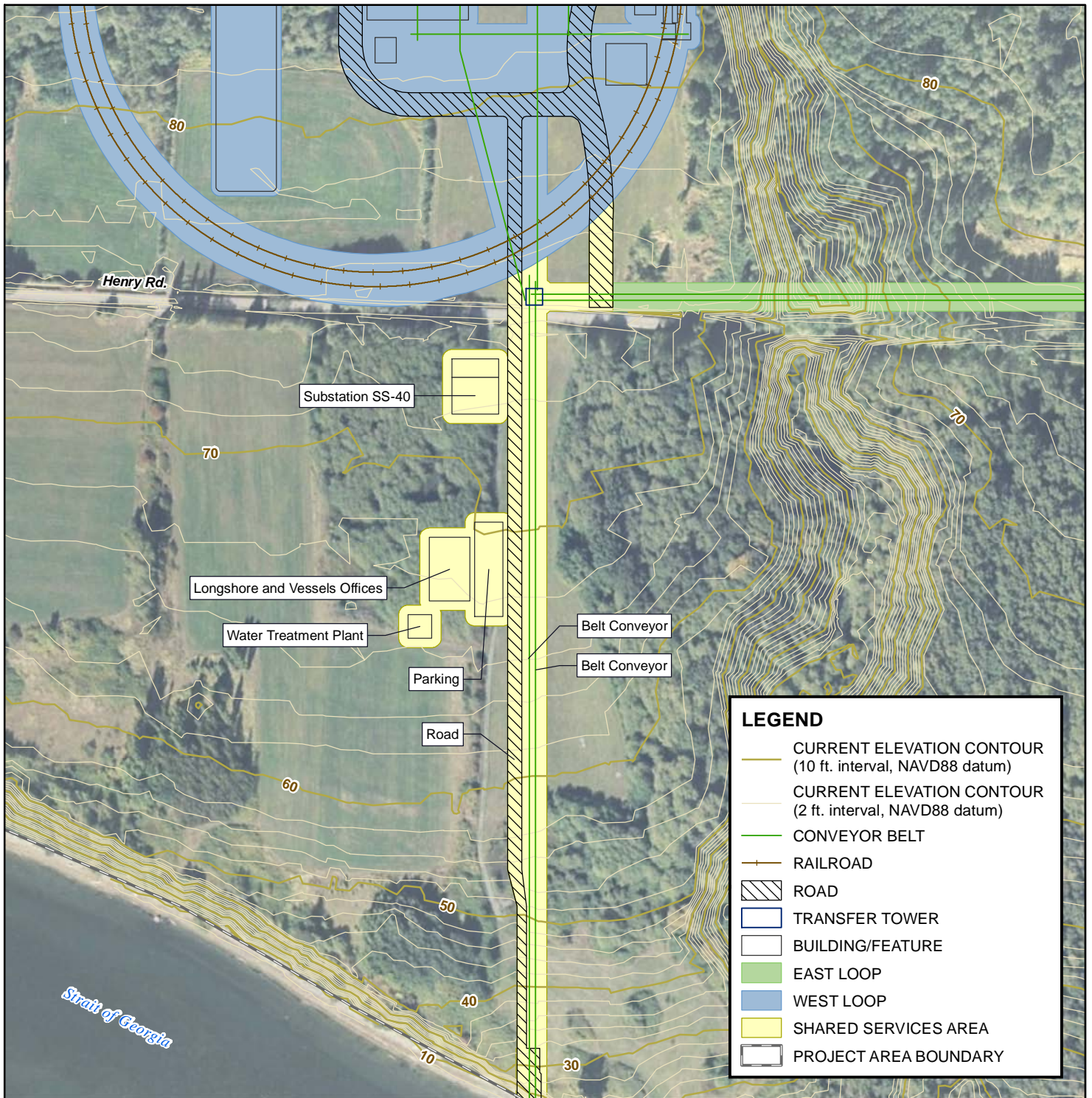

Source:  
 Ausenco Sandwell, 154199-A100-42S01.dwg (Rev. J), 12/24/2010.  
 David Evans & Associates, 2010-04-14-svTPXpiti0006-DEGROSS.dwg,  
 07/20/2010.

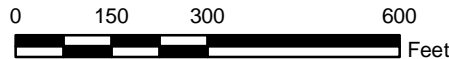

				CLIENT: <b>PACIFIC INTERNATIONAL          TERMINALS, INC.</b>	
PROJECT: <b>PROPOSED GATEWAY PACIFIC TERMINAL</b>		DWN BY: SD	DATUM: NAD83	DATE: FEBRUARY 2011	
TITLE: <b>SHARED SERVICES AREA</b>		CHK'D BY: KD	REV. NO.: 1	PROJECT NO.: 091515338C-18-01	
		PROJECTION: WA SP North, Ft.	SCALE: 1 inch=300 feet	FIGURE No.: <b>FIGURE 4-7</b>	



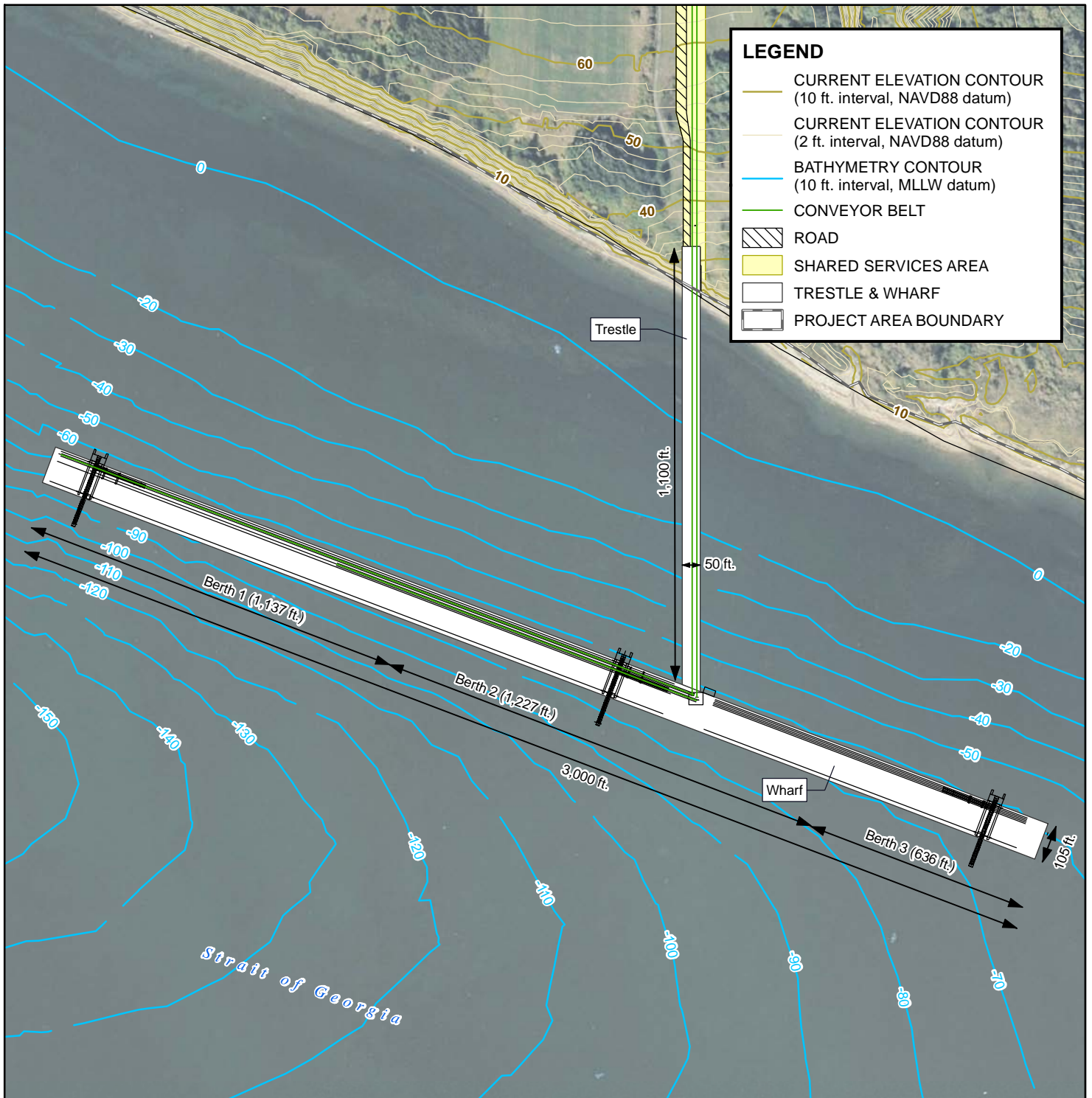

Source:  
 Ausenco Sandwell, 154199-A100-42S01.dwg (Rev. J), 12/24/2010.  
 David Evans & Associates, 2010-04-14-svTPXpiti0006-DEGROSS.dwg,  
 07/20/2010.

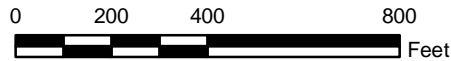

			CLIENT:				
			<b>PACIFIC INTERNATIONAL          TERMINALS, INC.</b>				
PROJECT:	<b>PROPOSED GATEWAY PACIFIC TERMINAL</b>  <b>WHARF AND ACCESS TRESTLE</b>	DWN BY:	SD	DATUM:	NAD83	DATE:	FEBRUARY 2011
TITLE:		CHK'D BY:	KD	REV. NO.:	1	PROJECT NO.:	091515338C-18-01
		PROJECTION:	WA SP North, Ft.	SCALE:	1 inch=400 feet	FIGURE No.:	FIGURE 4-8





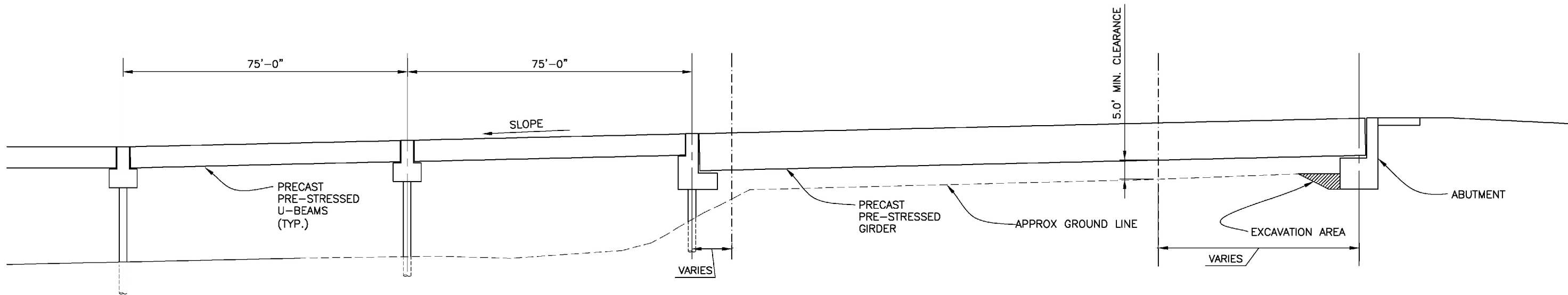

Source:  
Ausenco Sandwell, 154199-A700-50107.dwg (Rev. B), 12/13/2010.



CLIENT:  
**PACIFIC INTERNATIONAL TERMINALS, INC.**

DWN BY: SD  
CHK'D BY: KD  
DATUM: -  
PROJECTION: -  
SCALE: NOT TO SCALE

PROJECT:  
**PROPOSED GATEWAY PACIFIC TERMINAL**  
TITLE:  
**EXAMPLE CROSS-SECTION OF ACCESS TRESTLE**

DATE:  
FEBRUARY 2011  
PROJECT NO.:  
091515338C-18-01  
REV. NO.:  
1  
FIGURE NO.:  
FIGURE 4-9



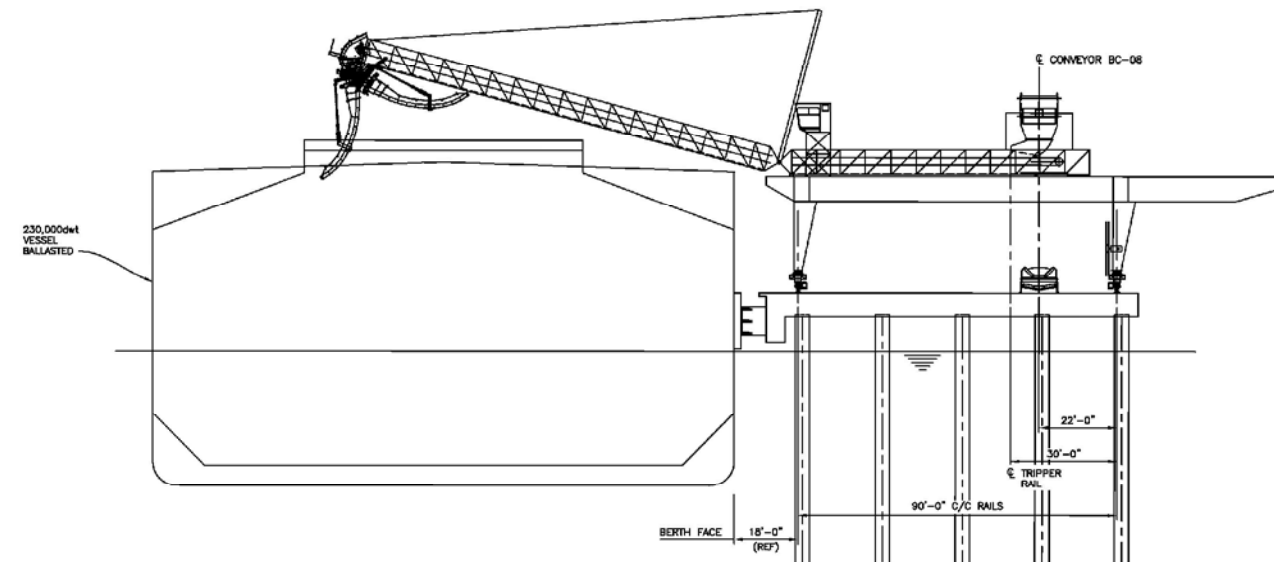

SHIPLOADER SHOWN @ MAX. UP  
AND MAX. FORWARD POSITION

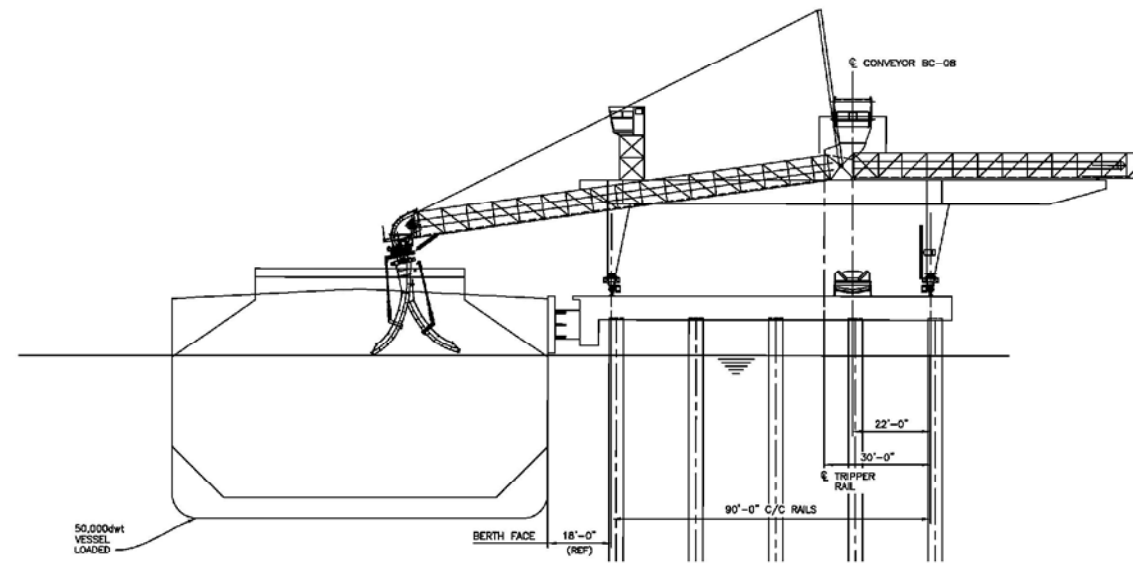

SHIPLOADER SHOWN @ MAX. DOWN  
AND MAX. RETRACTED POSITION

Source:  
Ausenco Sandwell, 154199-A600-42040-1.dwg (Rev. B), 05/21/2010.



CLIENT:  
**PACIFIC INTERNATIONAL TERMINALS, INC.**

DWN BY: SD  
CHK'D BY: KD  
DATUM: -  
PROJECTION: -  
SCALE: NOT TO SCALE

PROJECT:  
**PROPOSED GATEWAY PACIFIC TERMINAL**

TITLE:  
**EXAMPLE SHIPLOADER**

DATE: FEBRUARY 2011  
PROJECT NO.: 091515338C-18-01  
REV. NO.: 1  
FIGURE NO.: FIGURE 4-10



connections, which would allow vessels to use shore power while at berth. The arrangement of mooring equipment on the wharf would allow vessels to berth with either side against the dock, depending on the direction of the prevailing wind and current. The wharf would accommodate vessels with capacities of up to 250,000 dwt.

#### 4.3.5 Rail Access

The BNSF Railway would provide the main inland freight access via BNSF Railway's existing Pacific Northwest rail network. Specifically, the existing BNSF Railway's Bellingham Subdivision runs approximately north-south roughly parallel to Interstate 5 in the project vicinity. This main line feeds the Custer Spur, the only existing rail line developed to service the Cherry Point Industrial UGA. The Custer Spur branches west from the Bellingham Subdivision main line at Custer, then travels west, then south approximately 6 miles, terminating in the Cherry Point rail yard near the ConocoPhillips Refinery, the southernmost industrial facility in the Heavy Impact Industrial zone (Figure 4-11). Improvements to the Custer Spur are necessary to accommodate the number, length, and weight of trains that are anticipated to access the Terminal (Figure 4-11). Initially 7,000-foot-long trains are expected and longer trains up to 8,500 feet long may service the Terminal ultimately. To support the expected tonnages of bulk commodities to be handled at the Terminal, the following improvements would be made to the Custer Spur:

- Up to three receiving and departure tracks (called "receive/departure" tracks) would be developed on the south side of the BNSF Railway's Cherry Point Subdivision line starting from the Custer Wye through the Intalco Yard, Valley View Road, and to Ham Road (Figure 4-12). Each receive/departure track would be long enough to provide a holding area for trains up to 8,500 feet long to avoid blockage of at-grade public crossings or blocking of the BNSF Railway's main lines. Construction of the receive/departure tracks would include a new rail embankment, trackage, bridge, and drainage structures. A schematic cross section of the receive/departure tracks is shown in Figure 4-13.
- The Custer Spur's rails would be upgraded from the existing jointed light-rail sections to 141-pound, continuous-welded rail. This upgrade is needed to accommodate the expected tonnage of transported commodities and to manage efficiently the required maintenance demands resulting from increased numbers of trains while maintaining current service levels. This rail upgrade would also include any required rehabilitation of the existing rail ties and other existing railbed structural improvements.
- Pending terminal volume, a second track would be added along the complete length of the Custer Spur from the Custer Wye approximately 6 miles to the new proposed Terminal connection point (Figure 4-11). The Custer Spur currently services several existing industries by way of a single main line track. A second track would protect existing rail service and

switching capabilities for all customers along the line and efficiently accommodate increased rail traffic to and from the Gateway Pacific Terminal.

- A new terminal lead to connect existing tracks to the proposed Terminal would also be installed, and improvements would be made to BNSF Railway's existing Elliot Yard to support the additional rail connectivity (Figure 4-14).

No interdependent projects have been identified on the BNSF Railway's mainline—Bellingham Subdivision, or any other portion of BNSF Rail's infrastructure. BNSF would be the permitting applicant for any needed permits to complete improvements on the Custer Rail Spur. BNSF Railway would rely on this document to provide disclosure of potential effects under the requirements of NEPA and SEPA. Therefore, the description of the proposed action and affected environment for the Custer Spur improvements is provided and potential effects are analyzed in this document.

#### **4.3.6 Stormwater Management Systems**

The Gateway Pacific Terminal would require significant earthmoving during construction in an area with a number of known wetlands, streams, and drainage areas. As such, effective and active management of stormwater is essential to protecting local and downstream water quality and quantity.

This section describes the conceptual plan for a permanent stormwater management system to manage stormwater during both construction and operation of the Gateway Pacific Terminal. Specific procedures to protect water quality and temporary stormwater management systems that would be employed only during construction are described in Section 4.6.4.

To protect water quality and to regulate the volume of stormwater discharge from the facility during Terminal operations, a comprehensive stormwater management system would be constructed at the Gateway Pacific Terminal. As noted in Chapter 2, National Pollutant Discharge Elimination System (NPDES) industrial and construction stormwater general permits would be required from Ecology. The stormwater management system will be designed pursuant to the requirements of Whatcom County code and Ecology stormwater requirements.

The stormwater management system would be an integral part of the civil and geotechnical design of the Terminal, and would be developed pursuant to requirements of the Stormwater Manual for Western Washington (Ecology 2005). A feasibility study and conceptual design for a stormwater management system have been completed. A preliminary conceptual stormwater plan is presented in Figure 4-15. The final design and specifications for the stormwater management system would be completed as part of the facility design, environmental review, and NPDES permitting processes.







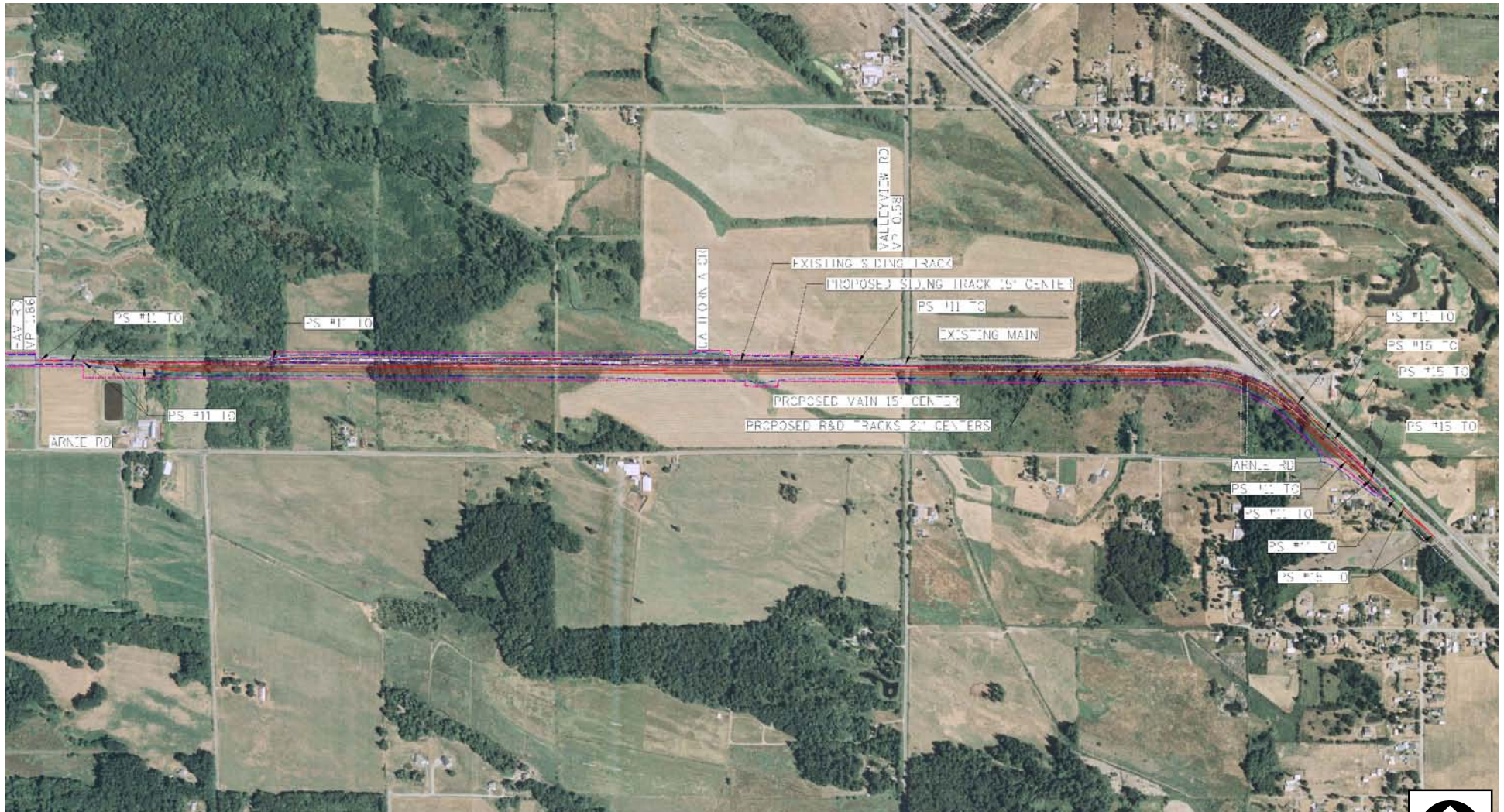

Source:  
Burlington Northern Santa Fe Railway(BNSF), C-1X001-R&D\_Tracks.dgn, 02/01/2011.



CLIENT:  
**PACIFIC INTERNATIONAL TERMINALS, INC.**

DWN BY: SD  
CHKD BY: KD  
DATUM: -  
PROJECTION: -  
SCALE: NOT TO SCALE

PROJECT:  
**PROPOSED GATEWAY PACIFIC TERMINAL**

TITLE:  
**PROPOSED BNSF R/D IMPROVEMENTS**

DATE:  
FEBRUARY 2011  
PROJECT NO.:  
091515338C-18-01  
REV. NO.:  
-  
FIGURE NO.:  
FIGURE 4-12



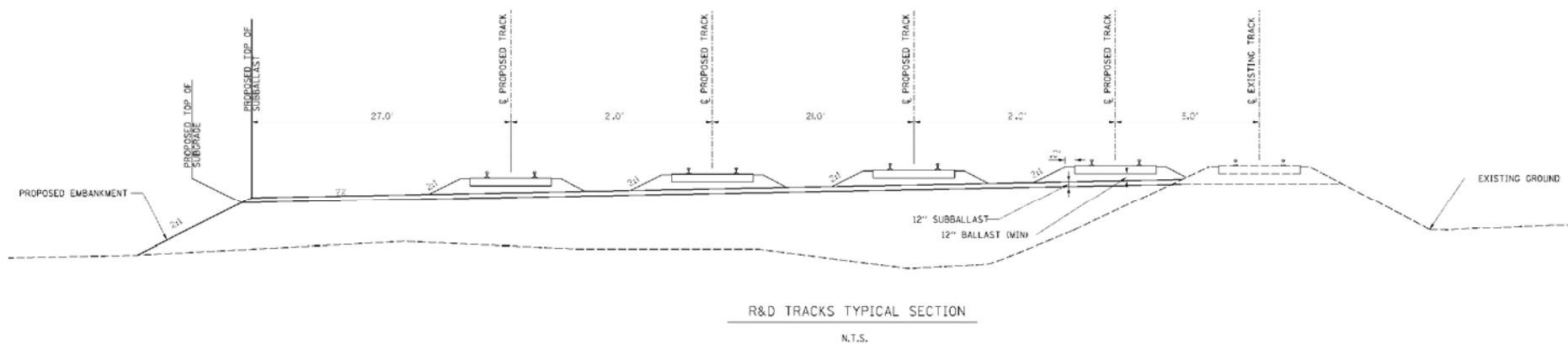
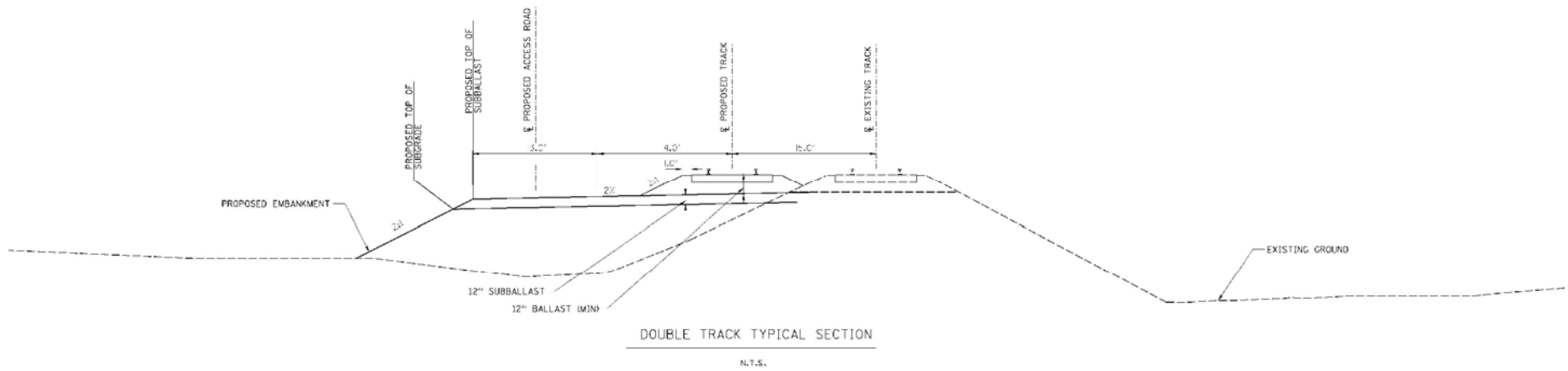

Source:  
Burlington Northern Santa Fe Railway(BNSF), C-3X001-TYP.dgn, 02/01/2011.



CLIENT:  
**PACIFIC INTERNATIONAL TERMINALS, INC.**

DWN BY: SD  
CHKD BY: KD  
DATUM: -  
PROJECTION: -  
SCALE: NOT TO SCALE

PROJECT:  
**PROPOSED GATEWAY PACIFIC TERMINAL**

TITLE:  
**PROPOSED BNSF TYPICAL RAILROAD SECTION**

DATE:  
FEBRUARY 2011

PROJECT NO.:  
091515338C-18-01

REV. NO.:  
-

FIGURE NO.:  
FIGURE 4-13





Source:  
Burlington Northern Santa Fe Railway(BNSF), C-1X002-Elliott Yard.dgn, 02/01/2011.



CLIENT:  
**PACIFIC INTERNATIONAL TERMINALS, INC.**

DWN BY: SD  
CHK'D BY: KD  
DATUM: -  
PROJECTION: -  
SCALE: NOT TO SCALE

PROJECT:  
**PROPOSED GATEWAY PACIFIC TERMINAL**

TITLE:  
**PROPOSED BNSF ELLIOTT YARD IMPROVEMENTS**

DATE:  
FEBRUARY 2011

PROJECT NO.:  
091515338C-18-01

REV. NO.:  
-

FIGURE NO.:  
FIGURE 4-14



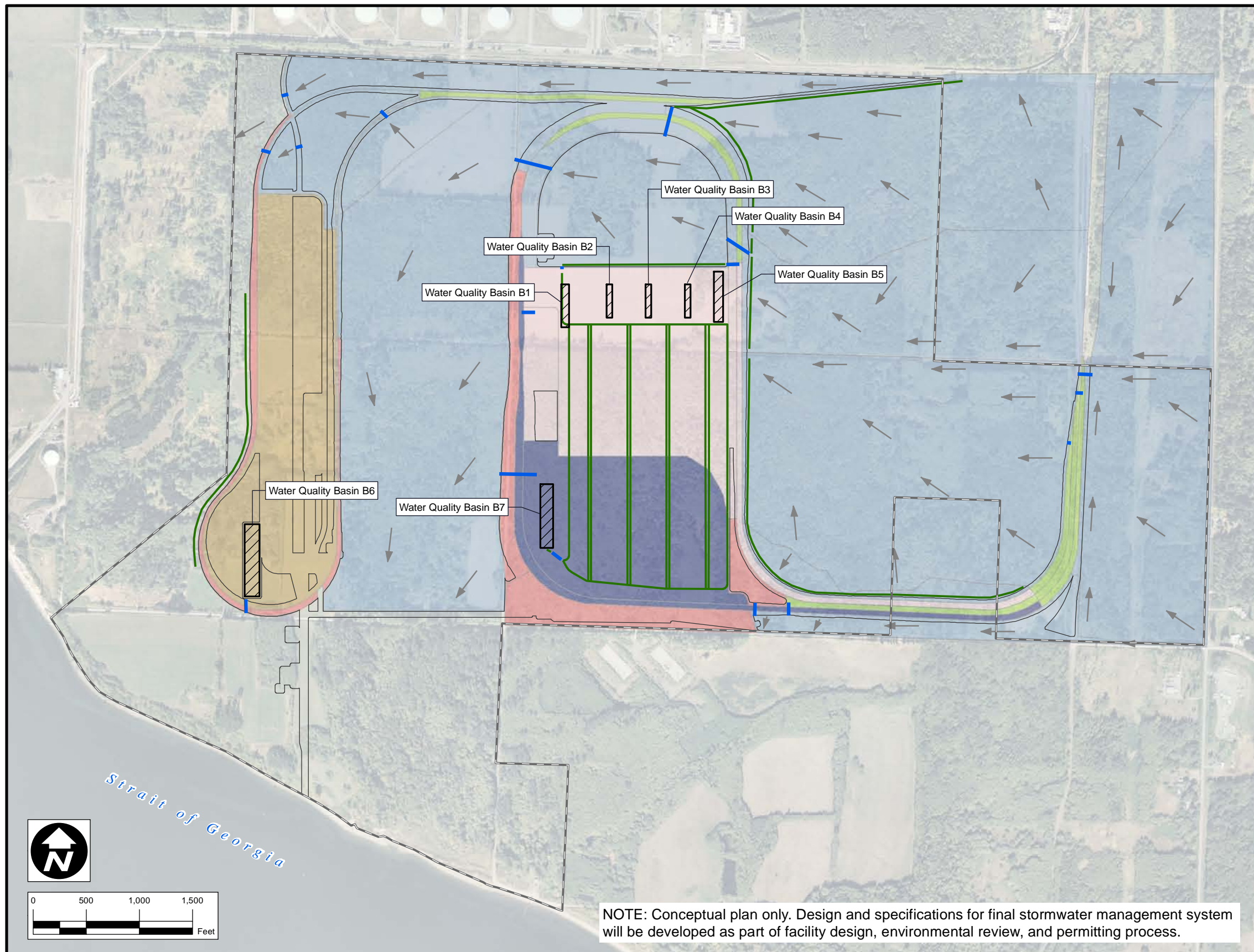

**LEGEND**

- PROPOSED SITE DITCH
- PROPOSED CULVERT
- CATCHMENT FLOW DIRECTION
- WATER QUALITY BASIN
- EXTERNAL CATCHMENT
- TRACK RUNOFF CATCHMENT
- UNTREATED CATCHMENT
- WQ BASIN B1-B5 CATCHMENT
- WQ BASIN B6 CATCHMENT
- WQ BASIN B7 CATCHMENT
- DEVELOPMENT FOOTPRINT
- PROJECT AREA BOUNDARY

NOTE: Conceptual plan only. Design and specifications for final stormwater management system will be developed as part of facility design, environmental review, and permitting process.

Source:  
 Ausenco Sandwell, 154199-A100-42S01.dwg (Rev. J), 12/24/2010.  
 Ausenco Sandwell, 143166-A100-48S01.dwg (Rev. P2), 02/04/2011.  
 Ausenco Sandwell, 143166-A100-48S02.dwg (Rev. P2), 02/04/2011.



CLIENT:  
**PACIFIC INTERNATIONAL TERMINALS, INC.**

DWN BY: SD  
 CHK'D BY: KD  
 DATUM: NAD83  
 PROJECTION: WA SP North, Ft.  
 SCALE: 1 inch = 1,000 feet

PROJECT:  
**PROPOSED GATEWAY PACIFIC TERMINAL**

TITLE:  
**STORMWATER DRAINAGE PLAN**

DATE: FEBRUARY 2011  
 PROJECT NO.: 091515338C-18-01  
 REV. NO.: 1  
 FIGURE NO.: FIGURE 4-15





As currently conceived (Figure 4-15), the stormwater management system would consist of the following features:

- A number of sediment-trapping stormwater management basins for detention and treatment of stormwater generated within the commodities-handling areas prior to discharge from the Terminal;
- A series of bioswales to capture and treat stormwater;
- A system of drainage ditches to convey stormwater to and from the sediment-trapping stormwater management basins and/or to existing natural drainage features;
- A water quality mitigation pond (covering about 36 acres) in the East Loop to receive treated stormwater from the treatment ponds as well as manage runoff from undeveloped portions of the Terminal property for the overall benefit of hydrologic functions (Section 5.4.6); and
- Created and enhanced streams and riparian systems to detain and filter significantly more stormwater than under current conditions, which would have a net benefit on wetlands hydrology.

It is currently anticipated that runoff from any area within the stockyards, commodity storage areas, roadways, parking and vehicle maintenance, and loading and unloading areas would be directed to the stormwater treatment systems (Figure 4-15). After collection and treatment, the treated stormwater would be released to the water quality mitigation pond or to constructed wetlands (see Section 5.4.6). Stormwater from undeveloped portions of the Terminal property or from areas within the development footprint that do not have the potential for becoming contaminated with pollutants, would be directed to natural and restored drainages and streams. Sheet flow on vegetated surfaces would be encouraged and concentrated flows avoided for natural drainage, allowing additional protection from sedimentation and erosion.

Construction stormwater management ponds would be built in the same locations as the containment areas for the final permanent stormwater management systems. Installation of the construction stormwater system will be among the first steps in site development and would be completed before other heavy earthwork is initiated at the Terminal (Section 4.6.4). Individual components of the stormwater management system would be designed to manage water quality for a wide range of particulates that may be entrained in stormwater during Terminal operations. Stormwater sediment-trapping basins would be designed to trap soil sediment effectively during construction. These basins would also be designed to contain runoff so that the volumes of stormwater runoff are maintained at pre-development levels. Finally, the runoff collection trenches would be aligned to follow existing and natural watercourse routes as much as possible.

#### **4.3.6.1 Stormwater Management Basins**

All runoff generated within the loading areas and storage areas in the East Loop and West Loop would be collected by low-velocity interceptor ditches and conveyed to a system of sediment-trapping stormwater management basins for detention and treatment prior to discharge from the Terminal (Figure 4-15).

Sediment-trapping basins would be located in both the East Loop and West Loop. The basins would be sized to manage the characteristics of specific commodities, for example, fine particles.

It is currently anticipated that the stormwater management basins would consist of a series of three individual bays separated by finger dikes. The three bays would provide sequential stormwater treatment consisting of:

- Bay 1: Initial settlement of coarse particles;
- Bay 2: Fine particle settlement and flocculation area; and
- Bay 3: "Polishing" bay.

It is anticipated that stormwater management basins would be developed using the following preliminary design criteria:

- Detain runoff volumes to maintain stormwater discharge at the regulatory predevelopment rates; and
- Provide sufficient dwell time so that fines or other suspended solids with diameters as small as 0.025 millimeters (mm) will settle.

Final design criteria will be established during the design and environmental review process. Treated stormwater from the sediment-trapping basins would be conveyed either to the water quality mitigation pond near the northern end of the commodities stockpile area or to restored or currently existing drainages. The water quality mitigation pond in the northern end of the East Loop would drain via a culvert installed in the existing watercourse as the embankment for the new railway is constructed.

The stormwater management basins would be functional during construction to control construction stormwater. Following construction activities, the stormwater management basins would be converted to permanent stormwater management basins for use during Terminal operations.

#### **4.3.6.2 Natural Drainage System**

A system of perimeter ditches, interceptor ditches, and collector swales would convey runoff toward water quality mitigation pond, or other natural drainages. These ditches and swales would be constructed as much as practical along the existing, permanent ditch and swale alignments. Vegetative lining would be provided in conveyance ditches and around the stormwater management ponds. The vegetative lining would help to reduce increases in water temperatures during sunny periods, trap sediment and possibly adsorb some deleterious constituents in the runoff, and minimize erosion. Open ditches would generally be V-shaped, with a maximum side slope of 2H: 1V. Catch basins may be required at remote low points. Where used, underground pipes would run parallel and perpendicular to the roads, from catch basins to the nearest ditches.

#### **4.3.6.3 Shared Services Area**

The Shared Services Area will not house commodities storage or handling facilities. It is currently anticipated that stormwater runoff from roads and parking lots in the Shared Services Area would be treated by infiltration using roadside bioswales.

#### **4.3.6.4 Access Trestle and Wharf**

A stormwater management plan for the trestle and wharf would be included in the facility stormwater management system. It is anticipated that a piped system to collect stormwater would be installed in areas on the access trestle and wharf where oils or fluids would be likely to occur, such as near the shiploaders. The industrial stormwater from these locations would be collected and piped to a treatment plant located in the Shared Services Area or West Loop. It is anticipated that stormwater from other portions of the access trestle and wharf that are not exposed to potential pollutants could be drained to the adjacent upland or into the water.

#### **4.3.7 Lighting**

All roads within the Terminal would be illuminated with 150-watt, pole-mounted lighting fixtures along the roadways and trestle to provide security for traffic movement. Stanchion, ceiling, or wall-mounted, 100-watt lighting fixtures would also be installed along the conveyor walkways and transfer towers to provide illumination for worker safety, and 400-watt floodlights mounted along the wharf conveyor would provide illumination for the working areas on the wharf. Marine directional lighting would be used to minimize lighting impacts on the marine environment.

#### **4.3.8 Utilities**

This section describes utilities and other ancillary facilities proposed to support the handling of dry bulk commodities at the Terminal.

#### **4.3.8.1 Wastewater Management**

Sanitary wastewater from buildings would be treated in separate treatment areas adjacent to each building. Three prefabricated (“package”) wastewater treatment systems would be established, one each for the East and West Loop facilities and one for the Shared Services Area. Treated wastewater from the treatment systems would be discharged to septic fields pursuant to applicable permits. Sanitary sewage from the washroom facility to be installed on the wharf would be treated, and the treated effluent would be trucked off site for treatment and disposal in accordance with applicable regulatory requirements.

#### **4.3.8.2 Industrial Water**

Whatcom County Public Utility District No. 1 is the designated water purveyor within the industrial area. Water supplied by Whatcom County Public Utility District No. 1 is not considered potable. Industrial, non-potable water would be supplied to the Terminal via a new, 12-inch underground pipe that connects to the existing industrial water main near the intersection of Henry Road and Kickerville Road. Water would be supplied throughout the Terminal from the main at Henry Road via several connection points. An 8-inch supply line would service the Shared Services Area, access trestle, and wharf.

#### **4.3.8.3 Drinking Water**

Potable domestic water for use at the facility would be provided by treating the industrial water provided by Whatcom County Public Utility District No. 1. Prefabricated (“package”) reverse osmosis treatment systems would be used to service each group of buildings. Potable water would not be provided for use on ships docked at the wharf.

#### **4.3.8.4 Electrical Supply**

Incoming electrical power would be provided at 115 kilovolts (kV). A new, dedicated 115 kV overhead line would interconnect to the existing Bonneville Power Administration (BPA) utility transmission system located adjacent to Aldergrove Road. A new main substation would be built near the connection point east of the East Loop rail embankment. The power would be distributed from this location at 34.5 kV to five large substations and at 4.16 kV to two smaller substations. One of the small substations would serve the administration and maintenance buildings and the second would serve the wharf. Preliminary estimated electrical demand, based on nominal capacity, is 25 megavolt amperes (MVA).

#### **4.3.8.5 Communications Infrastructure**

A central control room/operations center would be housed in the main administration building in the East Loop to provide communication control between all areas of the Terminal. Fiber optic cables

would be used for communications. A site radio network and a land-based telephone network would also be installed. A closed circuit video system would be installed to allow security surveillance. The security system would use dedicated fiber optic and/or radio channels in the communications infrastructure.

## **4.4 PLANNED TERMINAL CONSTRUCTION STAGING**

Large infrastructure involves large capital expenditures and large-scale construction activities. To spread the capital expenditures over time and reduce potential environmental effects associated with the large-scale construction, the Terminal would be constructed in two stages. During Stage 1 construction, the East Loop and other infrastructure required for opening the Terminal would be developed, including the trestle and wharf, while the West Loop area would be completed during Stage 2.

### **4.4.1 Stage 1 Terminal Construction**

Stage 1 would involve construction of all infrastructure needed to support initial bulk-handling operations at the Terminal. Stage 1 would include construction of the East Loop, the Shared Services Area, and the access trestle and wharf. Together these components would provide the infrastructure required to support dry bulk handling capacities approaching 25 Mtpa with open-air storage.

Stage 1 construction would include installation of the following elements:

- Access trestle and wharf with one shiploader connected to one belt conveyor line;
- The Shared Services Area, including the Longshoreman's services building;
- Compensatory mitigation for the fully developed facility (to address potential impacts of both Stage 1 and Stage 2 construction);
- Rail infrastructure required at full terminal capacity for the East Loop, including:
  - All bulk earthwork required for full terminal capacity, including the earthworks required to support four inbound rail lines and four outbound rail lines;
  - Tracks for two inbound rail lines and two outbound rail lines (two tracks would be installed at a later date), and
  - One rail unloading station;
- The entire East Loop stockpile patio area;
- Two stacker/reclaimer lines;

- Covered, elevated conveyor systems leading to and from the stacker/reclaimers and to the Shared Services Area;
- Access roadways and parking areas for the East Loop and Shared Services Area;
- Stormwater management facilities at the East Loop, Shared Services Area, wharf, and access trestle;
- Administration and maintenance buildings for the East Loop;
- All utilities that would be required at complete development, including water, electrical, wastewater management, and communications;
- Up to three receiving/departure tracks on the Custer Rail Spur near the Valley Yard; and
- Upgrade of the existing Custer Spur tracks to include structural hardening and continuous welded rail from the Valley Yard to the Terminal.

#### **4.4.2 Stage 2 Terminal Construction**

Stage 2 construction would complete the West Loop infrastructure, and provide improvements to the wharf to increase the material handling capacity by an additional 6 Mtpa of commodities. This stage of construction would add operating capacity and flexibility to handle different types and quantities of commodities at the Terminal.

Stage 2 construction would include installation of the following facilities:

- All of the West Loop's infrastructure including:
  - All bulk earthwork for the West Loop rail lines;
  - Construction of the West Loop rail lines;
  - One rail loading/unloading station;
  - Access roadways;
  - A-frame storage shed;
  - Bulk storage silos;
  - Conveyor lines; and
  - A stormwater management system;
- A second shiploader on the wharf connected to a new conveyor line on the access trestle; and
- A second conveyor line in the Shared Services Area.

### 4.4.3 Operational Phasing

Four operational phases dictated by the growth in capacity of the Terminal (nominal maximal throughput) are anticipated (Table 4-2).

**Table 4–2 Commodity Handling Capacity by Terminal Development Phase and Location**

Operational Phase	Approximate Year (estimated)	Capacity at West Loop (Mtpa)	Capacity at East Loop (Mtpa)	Total Nominal Maximum Terminal Capacity (Mtpa)
1	2015	0	25	25
2	2017	6	25	31
3	2021	6	39	45
4	2026	6	48	54

Mtpa millions of metric tons per year

The Terminal would begin operations at completion of Stage 1 construction with an operational capacity of approximately 25 Mtpa (Table 4-2). At the completion of Stage 2 construction, Terminal capacity would reach 31 Mtpa. Two subsequent operational thresholds are envisioned (achieved approximately by 2021 and 2026), with the maximum capacity of the Terminal (54 Mtpa) reached during Operational Phase 4.

Capacity would grow from 25 to 45 Mtpa during Phase 3 by addition of a third stacker/reclaimer at the East Loop to manage an additional stockpile of 1 million metric tons within the existing East Loop patio area. Additional equipment upgrades needed to accomplish this level of capacity would likely include:

- Two additional rail lines adjacent to the two existing lines in the East Loop (no new embankment would be needed because all earthwork was completed during Stage 1 construction);
- An additional shipping conveyor with its own surge bin, running from the East Loop to the Shared Services Area;
- An additional (third) conveyor in the Shared Services Area, access trestle, and wharf; and
- A third shiploader added to the wharf.

It is also anticipated that increasing the Terminal's capacity to 45 Mtpa would require a second main track along Custer Spur.

To reach the full operational capacity of 54 Mtpa, all of the infrastructure described above would be needed along with one additional stacker/reclaimer installed at the East Loop.

## 4.5 TERMINAL OPERATION

The terminal would operate to move large quantities of fairly uniform, granular, materials from rail transportation to oceangoing vessels. Single-commodity trains are made up of specific and consistent rail car types designed for efficient loading and unloading of commodities. Trains of this type are often called “Unit” trains as they travel as a “unit” from the production site to the Terminal. Unit trains support efficient routing, loading, and unloading and are typically designed for a specific commodity. The rail cars used to haul bulk commodities have varying lengths, and the Terminal will be designed to accommodate these variances with capabilities to handle train lengths up to 8,500 feet. Initially, unit trains approximately 7,000 feet long are expected to serve the Terminal, and the Terminal would provide capacity to potentially handle trains up to 8,500 feet long as volumes increase.

Once a train arrives at the Terminal, it would pass through the enclosed unloading station, and rail cars would be emptied two or more at a time into a bin beneath the rails. Some types of rail cars unload through bottom doors, while rotary gondola-style cars are flipped upside down to empty.

Once unloaded, the commodity would be moved from the dumper bin along large conveyor belts to a storage area, either open or covered. At the storage area, stacker/reclaimers would place the material in storage piles managed to minimize commodity loss and maximize the efficiency of handling. Enough material would be stored in the stockpiles at the Terminal so that a vessel could be loaded immediately once at berth. A “reclaimer” would scoop commodities from open stockpiles, or from inside storage structures, onto a conveyor that connects to a “shiploader.” Both machines are specifically designed for their purpose. A reclaimer needs to be able to reach almost all portions of a pile and move material quickly onto the conveyor belts. The shiploader is specifically designed to load a floating vessel safely, subject to tides and sensitive to load balance.

### 4.5.1 Employment

Operating hours for the Terminal are anticipated to be 24 hours a day, 365 days a year. When fully developed the Terminal is expected to employ 213 people. Table 4–3 shows the anticipated numbers of Terminal employees for each operational phase.

**Table 4–3 Estimated Number of Terminal Employees by Shift for Each Operational Phase**

Phase	Approximate Year (estimated)	Operational Capacity (Mtpa)	Number of Terminal Employees by Shift			Total
			7 AM–4 PM	3 PM–12 AM	11 PM–8 AM	
1	2015	25	39	26	24	89
2	2017	31	67	48	45	160
3	2021	45	83	61	57	201
4	2026	54	88	65	60	213



### 4.5.2 Commodities Likely to be Handled

A number of different dry bulk commodities are expected to be handled by the Terminal during its operational lifetime. Commodities handled would be driven by customer and market needs and by the specific terms of contracts negotiated with customers. Table 4–4 lists some of the most likely commodities that could be handled at the Terminal within the foreseeable future, and provides some of the physical properties for these materials.

It is anticipated that in the first 10 years, the Terminal would likely manage exports of low-sulfur, low-ash coal, Canadian potash, and locally produced calcined petroleum coke.<sup>1</sup> In the future, various grains are also likely export commodities because of increased overseas demand and high US production rates. Aggregate materials could likely be imported during terminal construction. Other dry bulk commodities listed in Table 4–4 could be handled for import or export.

Based on the physical properties, such as solubility or degradation when wet, covered storage would be required for some products for safe handling and to reduce potential environmental impacts. The East Loop is currently planned to provide uncovered storage and the West Loop to provide covered storage so that suitable facilities are available for various types of commodities.

### 4.5.3 Rail Operations Characteristics

The Terminal is designed to support sufficient and scalable rail infrastructure for efficient rail operations. Table 4-5 lists the number of trains anticipated to arrive at and depart the Terminal daily during the four operational phases, based on the assumption of trains up to approximately 7,000 feet long. The rail cars initially serving the East Loop would be rotary aluminum gondolas with a net carrying capacity of approximately 109 metric tons/car. Cars initially servicing the West Loop would be closed-top hopper cars with a net carrying capacity of approximately 102 tons/car. To manage up to 25 Mtpa, approximately five loaded trains per day would arrive at the Terminal. When the Terminal is developed to its full operating capacity, up to nine trains would arrive per day.

At approach to the Terminal and traversing the proposed terminal rail loops, trains would travel at average speeds of approximately 6 miles per hour (mph) unimpeded. It is estimated that a single train up to 125 cars long would be unloaded, on average, in 4 to 6 hours at the unloading station.

---

1. Calcined coke is a by-product of oil refining and is used as an energy source or a carbon-rich starting material for other manufacturing processes.

**Table 4-4 Likely Commodities to Be Handled at the Terminal and Their Properties**

Commodity	Solubility (mg/L)	Particle Size Range		Bulk Density	
		Generally as handled		(kg/m <sup>3</sup> )	Specific gravity
<b>Industrial Minerals</b>					
Alumina	very low	15% greater than No. 100 mesh 5% less than No. 300 mesh		961	3.4 - 3.6
Lime rock (crushed limestone)	negligible	Less than 3/8 inch diameter to very fine		1,550	1.7 - 3.0
Phosphate rock	negligible	Greater than No. 200 mesh		1,762	2.3- 2.6
Potash	Soluble: approx 357,000 mg/L @ 25°C	25% greater than No. 6 mesh 0.5% less than No. 14 mesh		1,281	2.0
Sulfur (prilled)	not soluble	Prilled pellets – varies by source		1,920 – 2,070	2.07 at 21°C
Salts	Soluble: approx 359,000 mg/L @ 25°C	1 – 5 mm		2,165	
<b>Grain Products</b>					
Barley	not soluble	Unhulled, dried, grain size		varies	See note 1
Corn	not soluble	Shucked, dried, grain size		varies	
Feed pellets/meal	Varies with product type	2 cm to 7 cm range		varies	
Soybeans	not soluble	Cleaned, dried beans		750	
Wheat	not soluble	Dried wheat berries		varies	
Oil seeds	not soluble	Clean seeds – size varies with type		varies	
<b>Carbon Products</b>					
Coal	not soluble	4% greater than 2 inch 29% less than No. 4 mesh		880	1.2
Petroleum coke (green)	not soluble	20% 6-inch minus 80% 3-inch minus		881	>1.0
Calcined petroleum coke	not soluble	40% less than No. 35 mesh 100% less than 18 mm		945	2.07
<b>Aggregates</b>					
Sand	negligible	<2 to 20 mm		1,650	2.3 - 2.5
Gravel	negligible	<1/2 inch		1,650	2.3 - 2.5
Crushed	negligible	<1/2 to 8 inch		1,650	2.3 - 2.5
<b>Wood Products</b>					
Wood chips		95% greater than 0.21 mm 96% less than 4 mm		varies	0.1 - 0.7
Wood pellets		1/4 inch to 2 inches		varies	
<b>Ores</b>					
Pelletized Ore	not soluble	4% greater than 16 mm 2% less than 5 mm		5,000	
Concentrate	0.01 - 1.4	lump: less than 38 mm fines: greater than 100 mesh		2,595	

Note 1. Grain products will generally sink. However, some individual grains will float for a short time until saturated, then will sink. The proportion that will sink or float depends in part on moisture content, which varies with grain, season, and source.

**Table 4-5 Trains per Day by Operation Phase**

Phase	Approximate Year (estimated)	Operational Capacity (Mtpa)	Serving West Loop				Serving East Loop				Total Terminal
			Loaded Trains	Cars / train	Metric tons/ car	Metric tons/ train	Loaded Trains	Cars / train	Metric tons / car	Metric tons / train	Loaded Trains
1	2015	25	0.0	0.0	0.0	0.0	5.0	125	109	13,625	5.0
2	2017	31	1.0	170	101.6	17,272	5.0	125	109	13,625	6.0
3	2021	45	1.0	170	101.6	17,272	6.5	150	109	16,350	7.5
4	2026	54	1.0	170	101.6	17,272	8.0	150	109	16,350	9.0

#### 4.5.4 Wharf Operational Characteristics

Upon initial development, commodities would be loaded into vessels at a rate of up to 10,000 metric tons per hour using a dedicated shiploader. Individual vessels would be loaded using a single shiploader. Typical operations for arriving vessels would include tug-assisted berthing, mooring, and preloading inspections. Once a vessel was cleared for loading, an operator would control the shiploader motions. The cargo selection and vessel loading plan would be managed through a central control room. Complete vessel loading typically takes multiple shifts over several days. Post-loading operations include a draft survey to confirm shipment size, releasing mooring lines, and tug-assisted deberthing.

#### 4.5.5 Dust Control Measures during Operations

Procedures would be implemented and equipment would be installed to control dust during operations at the Terminal. While different commodities may require specialized handling practices, the equipment and operating procedures identified below represent potential options to effectively address the management of dust in connection with wide-ranging commodities handling operations, including the storage and transfer of coal at the East Loop during initial operations.

As commodities handled at the Terminal change over time, Pacific International Terminals will continue to review and reassess the appropriateness and effectiveness of existing systems and implement other measures when appropriate to properly manage dust at the Terminal.

##### 4.5.5.1 Dust Control During Loading and Unloading Operations

Many commodities brought to the Terminal, including coal and potash, would be unloaded inside an enclosed rail car shed building at the unloading station. The shed would be equipped with a dust collection system to control dust during rail car unloading activities. The system would consist of internal baffles to capture dust for collection in fabric filters associated with the system. The system would effectively reduce dust emissions vented from the shed during rail car unloading activities to

less than 10 percent opacity. Figure 4-16 provides a photograph of an example rail car unloading shed with an associated dust collection system.

#### **4.5.5.2 Dust Control at Conveyors and Transfer Points**

Other than stacker/reclaimer conveyors at the commodities storage pile, all process conveyors designed to transfer commodities throughout the Terminal would be covered to minimize exposure to external conditions, thus reducing the potential for dust production. Only the conveyors associated with the stacker/reclaimers at the commodities storage pile would be uncovered. Figure 4-3 shows a photograph of a representative similar covered conveyor system. All conveyors over water would be fully enclosed in a gallery.

Specially designed passive enclosure dust controls, including staggered conveyor curtains and curved chuting, would be employed at transfer points to manage dust effectively during these operations. Figure 4-17 shows a schematic representation of this system and a photograph of an example system. For certain commodities, such as coal, a fog-based dust collection system would be used as needed during commodity transfer operations at the Terminal. These fogging systems generate water vapor droplets that adhere to the particles of a given commodity to reduce dust. Figure 4-18 provides a schematic diagram of an example fogger system.

#### **4.5.5.3 Dust Control at Commodities Stockpiles**

Uncovered storage of large quantities of dry particulate commodities has the potential to generate windblown dust. Dust control measures to be implemented at stockpiles would consist of a combination of compaction, fogging systems, water sprays, perimeter soil berms, regular pavement sweeping, and/or application of chemical surfactants. A water cannon would be located along the stacker/reclaimer lanes in the stockpile patio area. The water cannon would also be used to apply surfactant for additional dust suppression in the stockpile area when needed. Windscreens would be employed as needed to minimize dust generation during operations.

Water conservation features to be implemented would include controlling the dust suppression sprinkler system through an on-site meteorological station so that it would not operate during or just after rainfall, or when the stockpiled materials are sufficiently damp. The sprinkler would operate only during sunny periods, while also taking into account the drying effect of wind.

#### **4.5.6 Vessel Traffic**

Commodities would be moved by oceangoing vessel to and from the Terminal. Approximately 221 vessels (144 Panamax vessels and 77 Capesize vessels) are expected to call at the Gateway Pacific Terminal per year during Phase 1 operations. At full operational capacity, approximately 487 vessels per year are expected to call at Gateway Pacific Terminal (Table 4-6).



Source:  
Pacific International Terminals, Inc.



CLIENT:

PACIFIC INTERNATIONAL TERMINALS, INC.

DWN BY:

SD

CHKD BY:

KD

DATUM:

-

PROJECTION:

-

SCALE:

-

PROJECT:

PROPOSED GATEWAY PACIFIC TERMINAL

TITLE:

EXAMPLE RAIL CAR UNLOADING SHED

DATE:

FEBRUARY 2011

PROJECT NO.:

091515338C-18-01

REV. NO.:

-

FIGURE NO.:

FIGURE 4-16



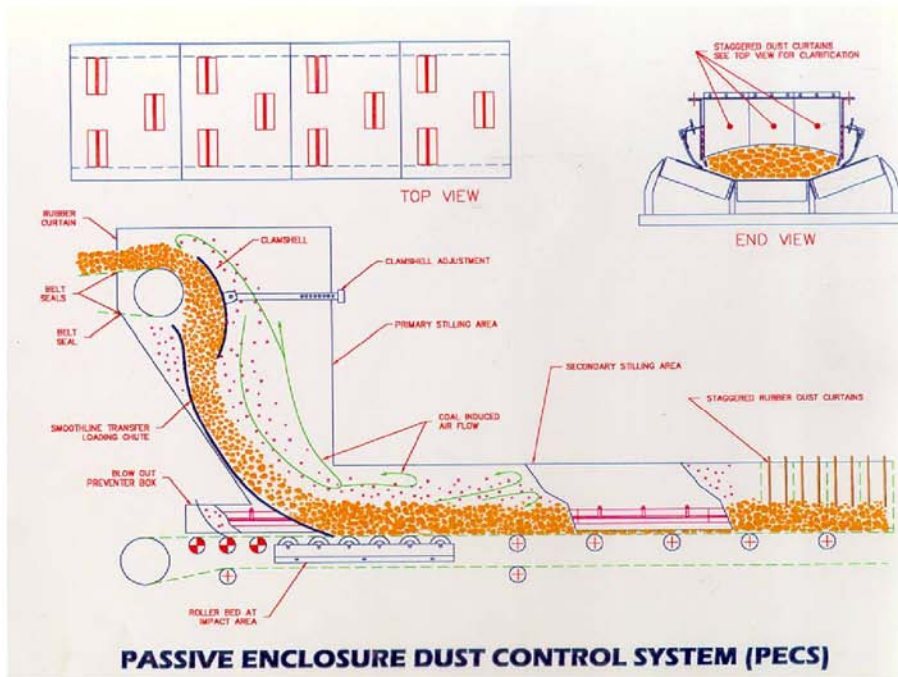

Source:  
Pacific International Terminals, Inc.

			CLIENT:				
			<b>PACIFIC INTERNATIONAL TERMINALS, INC.</b>				
PROJECT:	PROPOSED GATEWAY PACIFIC TERMINAL	DWN BY:	SD	DATUM:	-	DATE:	FEBRUARY 2011
TITLE:	SCHEMATIC DRAWING AND PHOTOGRAPH OF EXAMPLE PASSIVE ENCLOSURE DUST SYSTEM	CHK'D BY:	KD	REV. NO.:	1	PROJECT NO.:	091515338C-18-01
		PROJECTION:	-	SCALE:	-	FIGURE No.:	FIGURE 4-17





# Atomizer/Fogger System

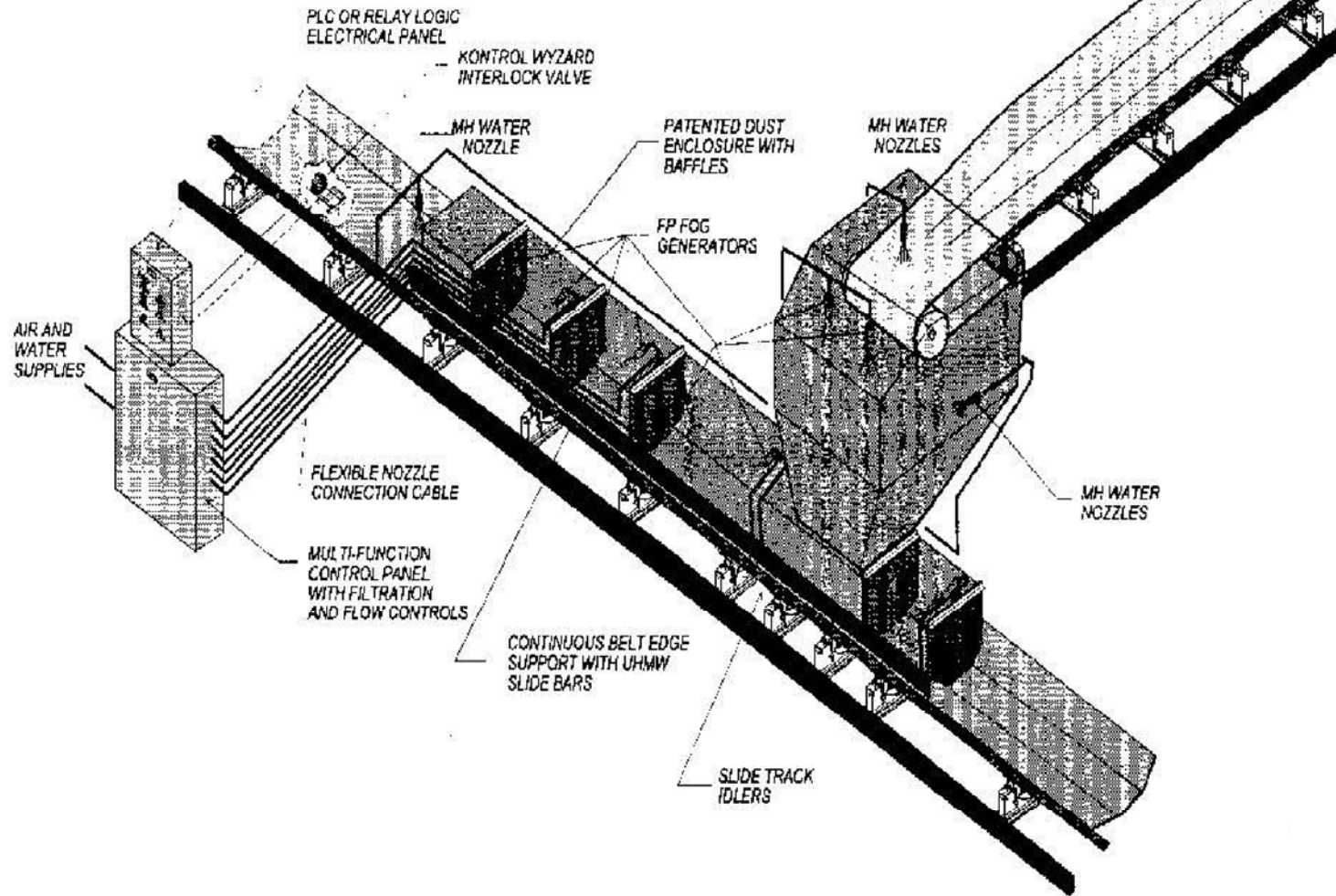

Source:  
Pacific International Terminals, Inc.



CLIENT:

PACIFIC INTERNATIONAL TERMINALS, INC.

DWN BY:

SD

CHKD BY:

KD

DATUM:

PROJECTION:

SCALE:

PROJECT:

PROPOSED GATEWAY PACIFIC TERMINAL

TITLE:

SCHEMATIC DRAWING OF  
EXAMPLE FOGGER SYSTEM

DATE:

FEBRUARY 2011

PROJECT NO.:

091515338C-18-01

REV. NO.:

FIGURE NO.:

FIGURE 4-18



**Table 4–6 Vessels per Year by Vessel Class and Operations Phase**

Operation Phase	Approximate Year (estimated)	Operational Capacity (Mtpa)	Capesize/yr		Panamax/yr		Total
			Serving East Loop	Serving West Loop	Serving East Loop	Serving West Loop	
1	2015	25	77	0	144	0	221
2	2017	31	77	31	144	59	311
3	2021	45	122	31	229	59	441
4	2026	54	138	31	259	59	487

### 4.5.7 Emergency Response

A site-specific emergency response plan would be developed and kept available at the Terminal at all times. The emergency response plan would specify safety procedures and spill and response measures to be implemented following an emergency or release of dangerous materials. The plan would also describe procedures for reporting and notification following an incident in a manner that is consistent with local, state, and federal rules and regulations.

Development of emergency response procedures would be coordinated with adjacent industries (BP and ALCOA), Whatcom County, the US Coast Guard, and other relevant agencies and individuals. Such coordination would include first responder protocols, notification plans, and contingency plans. The emergency response plans would define personnel responsibilities, actions to be taken, evacuation routes, and assembly areas, and would identify the location of water shutoff valves. A separate safety and emergency response plan would be developed for each specific commodity handled at the Terminal.

#### 4.5.7.1 Upland Spill Response

In the event of a spill of regulated petroleum products or hazardous materials, the appropriate Gateway Pacific Terminal personnel would contact the individuals and agencies identified in the site-specific emergency response plan, alert them to the status of the situation, and work closely with the supervising agency to address the matter appropriately.

The facility design and operational plans include a number of measures to reduce the risk of hazardous materials spills:

- Hopper doors on the rail cars would be closed after they have been emptied.
- An emergency cable would be deployed along the length of each conveyor so that the conveyors can be stopped immediately in the event of an emergency.

Additional spill response procedures would be described in the Emergency Response Plan and the Spill Prevention Control and Countermeasures (SPCC) Plan to be developed for the facility prior to initiating operations.

#### **4.5.7.2 Marine Spill Response**

A port operations manual including procedures for port operations, emergency response will be developed for operation of the marine terminal facility. The operations manual would define the responsibilities of vessel owners and operators calling at the Gateway Pacific Terminal including condition and safe operations of the vessel and spill response and countermeasures. A Spill Prevention Control and Countermeasures Plan for wharf and trestle operations would be developed and implemented and will include positioning of appropriate spill containment equipment.

#### **4.5.8 Energy Conservation**

The facility has been designed to include measures for electrical energy conservation:

- Capacitor banks would be used for power factor correction, which reduces the reactive component of current and losses.
- The primary distribution system would deliver power throughout the facility at 34.5 kV to reduce feeder losses with lower annual cost.
- Other energy conservation measures being considered include:
  - Loss evaluation of transformers to determine lowest life cycle cost,
  - Use of high efficiency motors,
  - Variable frequency conveyor drives; and
  - Use of energy-efficient lighting systems.

The use of variable frequency drives would help to reduce energy peaks when starting large motors by gradually ramping the motor up to speed thus reducing the current drawn.

### **4.6 CONSTRUCTION**

This section describes the projected construction schedule, the preliminary site preparation work needed to prepare the site for construction, and appropriate construction practices to be implemented to protect worker health and safety and the environment during the construction phase.

In general, the proposed project represents a combination of civil, site, and structural improvements to include both in-water and upland bulk handling infrastructure.

### **4.6.1 Terminal Construction Logistics**

Terminal construction would proceed in two stages to reduce environmental effects associated with construction and optimize fiscal management (Section 4.4). Stage 1 construction activities are anticipated to begin in 2013, after all permits and approvals are obtained, and to take approximately two years to complete. All construction for the East Loop, Shared Services Area, and access trestle would be completed during Stage 1. Remaining construction for the West Loop would be completed during Stage 2. No further earthwork would be needed within the Terminal to expand operations capacity beyond Stage 2 construction. Achieving full operational capacity following Stage 2 construction would involve installation of additional rail infrastructure, conveyors, stacker/reclaimers, and shiploaders to increase total freight-handling capacity. Because of the size of the in-water structures, it would take an estimated 18 months to complete the wharf and access trestle. The first commodities would be moved through the facility in early 2015 with the completion of the East Loop's initial rail infrastructure, and the wharf and trestle.

The nominal finished elevation of the East Loop would be 130 feet. The top of the rail embankment near the eastern-most portion of the East Loop rail embankment would be excavated to lower the elevation. This material removed would be used to fill the western portion of the East Loop area and to form the East Loop railway embankments. Based on current earthwork estimates, it is anticipated that excavated material in the East Loop would total approximately 7.3 million cubic yards, with the same volume required for fill, so that overall quantities of cut and fill are balanced.

Similarly, during Stage 2 construction of the West Loop, existing higher elevations in the northern vicinity of the West Loop would be cut to fill and raise the southern loop sections and to build rail embankments.

It is currently anticipated that any excavated overburden material would be stockpiled on site, and then later be incorporated into the constructed embankments. However, soil at the site is sensitive to moisture content, and preliminary analysis indicates it is not suitable for fill when wet. Therefore, most earthwork would be carried out during the summer months when the soil can be spread, worked, and dried if necessary to reduce its moisture content before final placement and compaction.

### **4.6.2 Wharf and Trestle Construction Logistics**

The access trestle and wharf would be constructed using floating equipment including one or more barge-mounted pile drivers, workboats, barges, and tugs. Equipment would also include concrete pumps and booms, welding and other miscellaneous equipment.

The trestle would be built by driving a combination of approximately 64 precast concrete piles and/or steel-pipe piles into the seabed using an impact and/or vibratory hammer. Piles are estimated to be

24 to 30 inches square, or in diameter, and estimated to average 122 feet long. Piling would be placed approximately 75 feet apart to minimize the number needed.

The wharf would be built by driving approximately 730 steel-pipe piles, each estimated to be up to 48-inches in diameter and estimated to average about 172 feet long. Piles would be driven into the seabed using an impact and/or vibratory hammer.

Piling will be delivered to the construction site by barge and driven to the proper depth. Deck construction is similar for the access trestle and wharf, and begins with construction of cast-in-place pile caps on the piling. Concrete deck beams span between the pile caps and are either cast-in-place or can consist of pre-cast beams placed with a marine derrick. Following the deck beams, the deck structure can also be cast-in-place concrete or constructed by placing pre-cast pre-stressed deck panels with a derrick. The wharf's piled foundations would provide support beneath the shiploaders, and lateral and transverse support to berthing forces. The deck would be overlaid, except in the grated area of the access trestle, with a wearing surface of up to 4-inches of asphalt. Conduits and electrical vaults would be built into the wharf structure to support potential future powering of vessels at berth with shore power. The wharf would also include crane rails to support the shiploaders, vessel mooring bollards, and a fender system.

### **4.6.3 Custer Spur Rail Construction Logistics**

Custer Spur construction sequencing is anticipated to progress as follows and will be based on Terminal volume requirements, with the objective of limiting impacts on future rail operations, the public, and the environment as additional freight volumes are realized during future operational phases at the Terminal.

- Civil/structural improvements for both the proposed receive/departure tracks as well as the double track along the Custer Spur would be completed concurrently with Stage 1 Terminal Construction.
- Rail infrastructure would be added as Terminal volumes warrant, starting first with the proposed receiving/departure tracks and eventually the proposed double track.
- Considering potential site and soil sensitivities, all heavy civil, grading, and embankment work is projected to be completed during the summer months and outside of the local wet season.

Preliminary construction sequencing for the railway improvements are summarized below:

- Mobilization, installation of work staging areas, and stormwater/sediment management facilities;
- Clearing/grubbing the entire construction footprint;

- Heavy civil construction work, including rough grading of construction footprint;
- Structural construction, including culverts and bridges along both R/D and double track segments (California and Terrell Creeks);
- Drainage profiling, including outfall protection and potential site mitigation;
- Final grading to include sub-ballast placement;
- Track construction to include surfacing; and
- Clean-up of the construction area and right-of-way.

Preliminary estimates project that construction of the BNSF Railway improvements would involve the following quantities of construction materials:

- 83,000 cubic yards of material imported for embankments,
- 36,000 cubic yards of excavated material moved to on-site embankments,
- 29,000 cubic yards of excavated material disposed off site,
- 140,000 cubic yards of rock fill material,
- 75,000 cubic yards of sub-ballast base material, and
- 100,000 cubic yards of rail ballast material.

#### **4.6.4 Construction Practices**

Construction will be planned to reduce environmental effects. Work would be scheduled to reduce effects to sensitive wildlife species and protect water quality, and effective management practices would be implemented to reduce potential effects due to stormwater runoff and dust generation.

Construction of the wharf and in-water portions of the approach trestle would occur during allowed in-water construction periods from approximately July 15 through February 15 in order to reduce potential effects on marine species. No in-water work would occur below the level of mean higher high water (MHHW) between February 16 and July 14 of any year.

Prior to commencing construction, a complete construction stormwater management plan, including a spill prevention, control, and countermeasures plan, would be prepared, and an NPDES General Construction Stormwater Management Permit would be obtained. The stormwater management plan would be designed to minimize the impacts to local water and environmental features associated with stormwater runoff during construction. The stormwater management plan would specify effective management practices to be implemented during construction, including sediment and erosion control

and water quality protection. While erosion hazards at the site are expected to be minimal due to moderate slopes in construction areas, appropriate erosion and sediment management practices would be implemented during construction to monitor and control the turbidity of runoff discharging from the project area and to control fugitive dust. The first steps of site development would be to build temporary construction-related stormwater management features. The final design and specifications for the construction stormwater management system would be developed as part of the environmental review and design process. Typically, a sediment-trapping geotextile filter cloth fence ("silt fence") would be installed around the perimeter of the construction area and/or around the perimeter of any isolated, standalone work area. The geotextile fabric would be embedded into the soil, with a sandy gravel berm installed along the toe at the upgradient side of the silt fence. Other temporary erosion and sediment control features identified in the construction stormwater management plan would also be established.

Following establishment of the temporary stormwater and erosion control features, sediment-trapping basins would be constructed. The outlets of these construction stormwater management basins would discharge treated water to selected discharge points that lead to the water quality mitigation ponds or to original watercourses. Next, the perimeter and interceptor ditches and collector swales that will all drain into the basins would be constructed. These ditches and swales would be constructed as much as practical along the existing, permanent ditch and swale alignments. No other bulk earthwork would commence prior to establishment of the stormwater management system.

During construction, site preparation, including earthmoving, cutting, and filling, would proceed consistent with the construction management plan. The ditches, sediment-trapping basins, and perimeter silt fences would all be monitored for sediment accumulation, which would be removed periodically. The ditches and swales would be regraded as required during construction until finished grade is achieved. Any sediment disturbed in the ditches would end up in the sediment-trapping basin, if it does not settle in the ditches. Permanent exposed cut surfaces would be vegetated, including those portions of the ditches that do not require smooth hard surfaces.

During earthmoving work, appropriate construction practices to control dust and sedimentation would be followed, as specified in the construction stormwater management plan. These practices could include stabilizing areas quickly following earthwork, using water-spraying trucks in work areas to control dust, sweeping/and or installing wheel washes at truck entrance and egress areas, and other appropriate housekeeping procedures.

During construction, spill containment facilities would be constructed and maintained around the equipment fueling area, to supplement drip trays and other control works.



## CHAPTER 5 ENVIRONMENTAL RESOURCES AND PROJECT EFFECTS

This section describes the existing natural and human environment in and around the proposed project area and describes the potential effects of the proposed Terminal on these resources. Where effects are identified, measures to avoid, minimize, or mitigate those effects are identified. The measures described in this Chapter are to be considered as incorporated into the Terminal design as committed design features.

The description of existing conditions and assessment of effects is based on the best information available at the time of filing of this Project Information Document. For some resource areas, minimal or incomplete information is available and in some resource areas, older data do not adequately represent current conditions in the project area. For those resource areas with incomplete or out-of-date data, new or updated technical studies are underway, and the results will be made available to the permitting agencies, environmental review team, concerned Tribes, and other interested stakeholders as soon as they are available.

Table 5-1 lists ongoing studies and technical reports to be added to the project file, the estimated schedule of their completion if known, and the section in this document that summarizes the available information for the applicable topic area:

**Table 5-1 Pending Studies and Reports**

<b>Report</b>	<b>To Be Used to Augment Section:</b>		<b>Anticipated Completion Date</b>
<b>Traffic Report (update)</b>	5.6	Roadway and Railroad Transportation	April 2011
<b>Air Quality Impact Analysis</b>	5.7	Air Quality	April 2011
<b>Economic Impact (update)</b>	5.9	Socioeconomic Environment	April 2011
<b>Site Area Wildlife Survey (Birds)</b>	5.2	Upland Vegetation, Wildlife, and Habitat	June 2011
<b>Biological Evaluation</b>	5.3	Marine Resources	March 2011
<b>Essential Fish Habitat Evaluation</b>	5.3	Marine Resources	March 2011
<b>Marine Current and Tides</b>	5.3	Marine Resources	May 2011
<b>Marine Sediment and Water Quality</b>	5.3	Marine Resources	July 2011
<b>Nearshore Macroalgae</b>	5.3	Marine Resources	June 2011
<b>Hydrology</b>	5.2	Wetlands, Streams, and Other Drainages	May 2011
<b>Geotechnical (Marine and Upland)</b>	5.1	Earth	August 2011
<b>Cultural Resources Findings</b>	5.5	Archaeological, Cultural, and Historic Resources	March 2011
<b>Noise Impact Analysis</b>	5.15.1	Noise	April 2011
<b>Vessel Traffic Study</b>	5.15.5	Commercial and Recreational Navigation	July 2011

A section is included in this chapter for each relevant environmental resource that may potentially be affected by the Terminal. These sections have been completed to the greatest extent possible with the currently available information. As the studies listed above are completed, they will be provided to the Multi-Agency Permitting Team and interested stakeholders, along with updated sections of Chapter 5 of this Public Information Document, when appropriate. In addition, this Project Information Document may be supplemented periodically as new information and analyses are developed that address cumulative and other impacts.

## **5.1 EARTH**

This section describes the existing physical characteristics of the project area and surrounding properties and provides an assessment of the potential environmental impacts of the Terminal on topography, geology, and soils. The site geology and soils dictate geotechnical design, including the type of foundations needed to support the structures and specifications of the earthwork required to support related infrastructure and utilities. Facility design and construction methods can in turn have impacts on site physical characteristics.

Key issues of concern related to topography, geology, and soils include:

- Minimizing disturbance to surface soils at the Terminal site, and
- Developing the site in a manner that creates stable surfaces and minimizes potential for erosion and sedimentation.

### **5.1.1 Affected Environment**

This section describes the existing topography, soils, and geology of the project area and surrounding areas, including seismic characteristics.

#### **5.1.1.1 Topography and Geology**

Unstable slopes are not present in the project area except for areas along the shoreline. Generally flat to gently rolling slopes characterize the terrain. Elevations range from 70 feet below mean sea level (msl) at the proposed location of the wharf to a little more than 180 feet above mean sea level along the eastern site boundary. The highest land elevations occur nearest the eastern property boundary, with site elevation gradually decreasing to the west and to the south (Figure 5-1). Moderate slopes and steep bluffs border the westernmost stretch of shoreline. Stream 1 flows through a ravine in the south central portion of the property and drains to the Strait of Georgia (Section 5.1).

Previous geotechnical studies (GeoEngineers 1997 and 2010; Shannon & Wilson, Inc. 1993) described the project area lying within an area mapped by others as the Bellingham glaciomarine drift.



**LEGEND**

 PROJECT AREA BOUNDARY

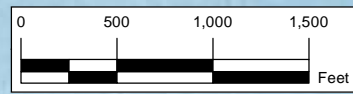

Source:  
 NGS USA Topographic Maps provided by ArcGIS Map Service:  
<http://server.arcgisonline.com/v93>  
 U.S. Geological Survey, Lummi Bay quadrangle, Washington,  
 1:24,000, Washington D.C.: USGS, 1973.



CLIENT:  
**PACIFIC INTERNATIONAL TERMINALS, INC.**

DWN BY: SD  
 CHK'D BY: KD  
 DATUM: NAD83  
 PROJECTION: WA SP North, Ft.  
 SCALE: 1 inch = 1,000 feet

PROJECT:  
**PROPOSED GATEWAY PACIFIC TERMINAL**  
 TITLE:  
**USGS TOPOGRAPHIC MAP**

DATE:  
 FEBRUARY 2011  
 PROJECT NO.:  
 091515338C-18-01  
 REV. NO.:  
 1  
 FIGURE NO.:  
 FIGURE 5-1



Geologic strata characterized as Vashon Stade Advance Outwash and Cherry Point Silt underlie the glaciomarine drift.

The surficial Bellingham glaciomarine drift unit consists of unsorted, unstratified silt and clay with varying amounts of sand, gravel, cobbles, and occasional boulders. Glaciomarine drift is derived from sediment entrained in floating glacial ice that melts, with the sediment deposited on the seafloor. This material typically contains shells and wood fragments. The Bellingham glaciomarine drift is thought to have been deposited during the Everson Interstade (a period between glacial periods) approximately 11,000 to 12,000 years before present. At that time, the land surface was depressed 500 to 600 feet below current levels due to the weight of glacial ice during previous glaciation periods.

The Vashon Stade, a substage of the Vashon glaciation marked by the re-advance of glaciers, occurred between approximately 11,000 to 18,000 years ago. Sand and gravel outwash was deposited by meltwater streams in front of and along the glacial ice. As the glacier advanced, the advance outwash was eventually overridden by the glacier. As the ice retreated, recessional outwash, similar in gradation to the advance outwash, was deposited.

The retreat of the Vashon-Stade Glacier approximately 13,000 years before present left the Cherry Point area at least partially submerged below sea level. The retreating ice deposited glacial debris, gravel, sand, and rock, forming depositional units up to several hundreds of feet thick. Over time, waves reworked and re-deposited the upper layers. The land surface rebounded upward from glacial compaction, while sea level dropped, bringing the area above sea level.

The pre-Vashon sediments for the site include the Cherry Point Silt. The glacially over-consolidated Cherry Point Silt consists of stratified marine clay and silt with minor sand interbeds.

According to Shannon & Wilson (1993), Cherry Point is located in the northern reaches of the Puget Lowland, which is a moderately active tectonic province. During the brief 165-year recorded history of seismic events in the Pacific Northwest, this region has been subjected to numerous small to moderate sized earthquakes and occasionally to strong earthquakes. The four largest earthquakes to have affected the northern portion of the Puget Sound Lowland during the historic period include:

- North Cascade earthquake, December 14, 1872: magnitude 7.3;
- Vancouver Island earthquake, June 23, 1946: magnitude 7.3;
- Olympia earthquake, April 13, 1949: magnitude 7.1; and
- Sea-Tac Earthquake, April 29, 1965: magnitude 6.5.

These events had Modified Mercalli intensities ranging from VIII (1946, 1949, and 1965) to XI (1892) at the epicenter. Even so, Shannon & Wilson (1993) reported that none of these events exceeded intensity VI at Cherry Point. They estimated that intensity VI ground shaking would correspond to a peak ground acceleration of about 0.1 g, the maximum ground shaking to have historically occurred at the site. Shannon & Wilson (1993) proceed to recommend peak ground accelerations of 0.12 g and 0.27 g for Level 1 and Level 2 seismic designs, respectively.

The project geotechnical engineer, GeoEngineers, Inc., plans additional geotechnical investigations for 2011. These investigations will include assessment of upland and marine areas and final geotechnical design recommendations. A geotechnical data report is anticipated to be available for uplands by May 2011 and for marine areas by October 2011.

### **5.1.1.2 Soils**

This section presents both the soils classifications and descriptions for the project area based on both the Natural Resources Conservation Service (NRCS) maps and site-specific geotechnical investigations. The Soil Taxonomy classifications are used by environmental engineers, land use planners, agronomists, and wetlands specialists as a tool in the site evaluation and planning process. Geotechnical soils classifications are used by civil engineers to determine design requirements for subsurface and surface structures and related infrastructure.

### **Soil Taxonomy**

The NRCS has identified and mapped seven soil series within the project area (Figure 5-2): Birchbay silt loam, Edmonds-Woodlyn loam, Hale silt loam, Kickerville silt loam, Neptune very gravelly sandy loam, Whatcom silt loam, and Whitehorn silt loam. Table 5-1 presents selected characteristics of each soil series. Soils are usually considered to include only the top 40 inches of depth.

### **Geotechnical Classifications**

Soil interpreted to be glaciomarine drift was encountered in the previous geotechnical borings advanced in uplands areas at the project site (GeoEngineers 1997, 2010). The glaciomarine drift is classified as very stiff in the upper near-surface layers, transitioning to medium stiff to soft or very soft with depth. The glaciomarine drift generally consists of clay and silt to sandy clay with variable gravel content. The glaciomarine drift deposits extend to depths of up to 120 feet below ground surface (bgs). The lower 30 to 50 feet of the glaciomarine drift in some of the borings was interpreted to be a transition zone, with significant interbedding and increased sand and gravel content beyond that typically attributed to the glaciomarine drift unit, including lenses and layers of clayey and silty sand.

Material interpreted to be glacial outwash was encountered below the glaciomarine drift in previous geotechnical borings. The glacial outwash generally consists of dense to very dense silty sand with

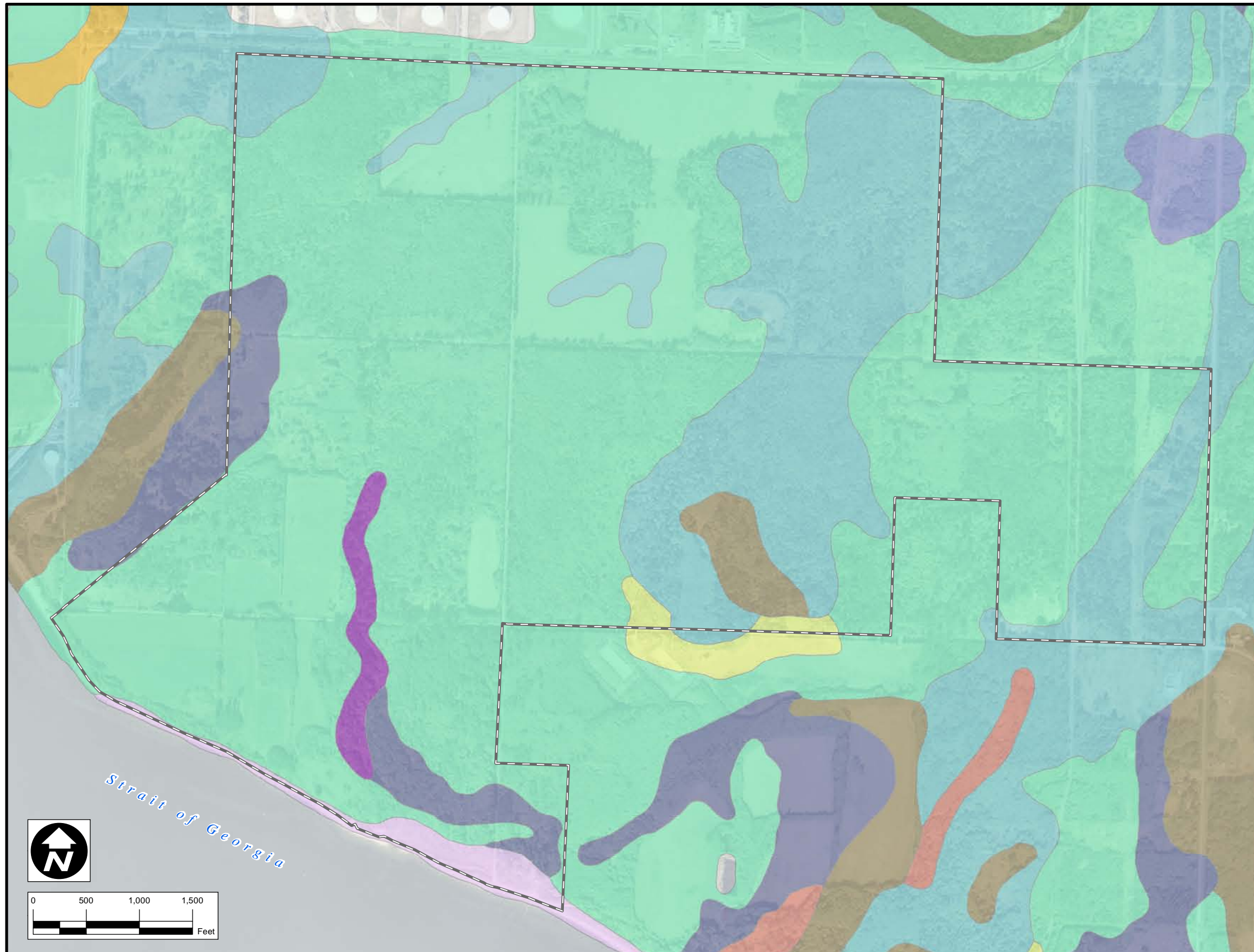

LEGEND	
<b>SOIL CLASSIFICATION:</b>	
	BIRCHBAY SILT LOAM (0 to 3 percent slopes)
	BIRCHBAY SILT LOAM (3 to 8 percent slopes)
	BIRCHBAY SILT LOAM (8 to 15 percent slopes)
	CLIPPER SILT LOAM - DRAINED (0 to 2 percent slopes)
	EDMONDS-WOODLYN LOAMS (0 to 2 percent slopes)
	HALE SILT LOAM - DRAINED (0 to 2 percent slopes)
	KICKERVILLE SILT LOAM (3 to 8 percent slopes)
	NEPTUNE VERY GRAVELLY SANDY LOAM (0 to 3 percent slopes)
	TROMP LOAM (0 to 2 percent slopes)
	WHATCOM SILT LOAM (30 to 60 percent slopes)
	WHITEHORN SILT LOAM (0 to 2 percent slopes)
	PROJECT AREA BOUNDARY

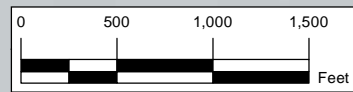

Strait of Georgia

Source:  
Soil Classification data from U.S. Department of Agriculture:  
<http://SoilDataMart.nrcs.usda.gov>



CLIENT:  
**PACIFIC INTERNATIONAL TERMINALS, INC.**

DWN BY: SD  
CHK'D BY: KD  
DATUM: NAD83  
PROJECTION: WA SP North, Ft.  
SCALE: 1 inch = 1,000 feet

PROJECT:  
**PROPOSED GATEWAY PACIFIC TERMINAL**  
TITLE:  
**NATIONAL RESOURCES CONSERVATION SERVICE  
SOIL MAP**

DATE:  
FEBRUARY 2011  
PROJECT NO.:  
091515338C-18-01  
REV. NO.:  
1  
FIGURE NO.:  
FIGURE 5-2





**Table 5-2 Mapped Soil Series in the Project Vicinity**

<b>Soil Series</b>	<b>Slope (percent)</b>	<b>Drainage Class</b>	<b>Parent Material</b>	<b>Landscape Position</b>
Birchbay silt loam	0 to 3	Moderately well drained	Volcanic ash, loess, glaciofluvial deposits, and glaciomarine drift	Glaciomarine drift plains
Birchbay silt loam	3 to 8	Moderately well drained	Volcanic ash, loess, glaciofluvial deposits, and glaciomarine drift	Glaciomarine drift plains
Birchbay silt loam	8 to 15	Moderately well drained	Volcanic ash, loess, glaciofluvial deposits, and glaciomarine drift	Terraces and plains
Edmonds-Woodlyn loam	0 to 2	Poorly drained	Volcanic ash, loess, and glacial outwash	Outwash terraces and outwash plains
Hale silt loam (hydric)	0 to 2	Poorly drained	Volcanic ash, loess, and glacial outwash	Outwash terraces
Kickerville silt loam	3 to 8	Well drained	Volcanic ash, loess, and glacial outwash	Outwash terraces
Neptune very gravelly sandy loam	0 to 3	Excessively drained	Coastal beach deposits	Marine ridges, spits, and terraces
Whatcom silt loam	30 to 60	Moderately well drained	Volcanic ash, loess, and glaciomarine drift	Glaciomarine drift plains
Whitehorn silt loam (hydric)	0 to 2	Poorly drained	Volcanic ash, loess, glaciofluvial deposits, and glaciomarine drift	Glaciomarine drift plains

occasional gravel to gravel with sand and silt. The glacial outwash deposits extended to the full depth (131.5 feet) explored in previous subsurface explorations.

Offshore soils interpreted to be glacial outwash were encountered in previous geotechnical borings advanced during investigations for the proposed trestle and wharf plans of 1997 (Shannon & Wilson 1993). The glacial outwash encountered in borings generally consisted of very loose to loose (near the mudline) silty sand with occasional gravel to gravel with sand and silt, transitioning to dense to very dense with depth. The boring logs noted significant interbedding with depth and increased silt and clay content, including lenses and layers of clayey and silty sand and layers of sandy clay and silt. The glacial outwash deposits extended to the full depth explored in the previous explorations.

## 5.1.2 Potential Effects on Topography, Soils, and Geology

This section summarizes potential effects of the Terminal on topography and soils.

### 5.1.2.1 Topography

Substantial areas within the East Loop and West Loop will be graded to create level surface for rail embankments and commodity storage areas. Grading would alter the existing topographic elevations to create large level areas for commodity handling. Filling and compaction would be needed to create level rail embankments and level areas for construction of other required infrastructure, such as

buildings. Even though the onshore portions of the project area are largely flat, the existing topography would be altered to new contours in many locations within the project footprint.

An in-depth geotechnical engineering evaluation is currently underway, and a complete civil engineering evaluation will be conducted as part of the final Terminal design. The design will include recommendations and specifications to maintain stable earth structures and prevent erosion hazards. These will include recommendations for erosion control measures, construction stormwater management and drainage, final facility stormwater management, cut and fill specifications, and earthworks and shoring to maintain site stability.

### **5.1.2.2 Geotechnical Soil Conditions**

Geotechnical soil conditions underlying the site vary in complexity and would affect the planned Terminal development in several ways. This section summarizes these potential effects as previously reported in available geotechnical documents or as currently interpreted for the currently proposed Terminal. This section also presents strategies identified to reduce these impacts.

### **5.1.2.3 Onshore Structures and Site Development**

Previous exploration programs (GeoEngineers 1997, 2010) produced consistent results: glaciomarine drift in the project area overlies advance outwash, with a transitional zone between the two units. The glaciomarine drift was typically stiff to very stiff silt and clay grading softer with depth, and the transitional zone varied between medium stiff to stiff. The glaciomarine drift and transitional zone were much thicker (over 100 feet) in the explorations at the center of the site than at the southern perimeter of the site (approximately 45 to 50 feet). GeoEngineers (1997, 2010) provided the following conclusions for preliminary planning purposes:

- Lightly loaded structures can typically be supported using conventional shallow foundations without excessive settlement from foundation loads.
- Large, heavily loaded foundations would transfer loads to the soft, compressible glaciomarine drift.
- If deep foundations are necessary because of high loads, high capacity end-bearing piles are feasible at the southern end of the site where the advance outwash was encountered at shallower depths. In the northern portions of the site, deep foundations will likely consist of lower capacity friction piles because of the greater depth to bearing soils (greater than 120 feet at recent boring locations).
- Large aerial fills and embankments will be prone to settlement resulting from consolidation of the soft clayey soil underlying the site. Design features to address and mitigate potential settlement are presented in Section 5.1.3.

#### **5.1.2.4 Offshore Wharf and Trestle Structure**

Conditions encountered during previous explorations (Shannon & Wilson 1993) have been interpreted to be glacial outwash. The glacial outwash encountered in borings generally consisted of very loose to loose (near the mudline) silty sand with occasional gravel to gravel with sand and silt, and transitioned to dense to very dense with depth. Deep foundations will be necessary to accommodate high loads and the need to carry the trestle and wharf above sea level.

#### **5.1.2.5 Rail Loops**

Based on the American Railway Engineering and Maintenance-of-Way Association (AREMA) standards, the clay and silty to sandy clay composing the glaciomarine drift is considered a “poor” to “bad” subgrade for a railway embankment. Under these conditions, geotechnical risks arise without adequate subgrade preparation. These geotechnical risks include medium- to high-severity frost heave, fair to poor drainage, and slight to high severity pumping action along the rail alignments.

### **5.1.3 Proposed Design Features Intended to Reduce Impacts**

This section describes design features incorporated into the proposed project to reduce environmental impacts associated with the Terminal. Plans for the Terminal would concentrate development within two rail loops, allowing major portions of the project area to remain unaltered.

Design of the Terminal has balanced the quantities of excavated soil and fill at the Terminal. Thus, transportation of excavated soils that are unusable as fill, such as organic soil, peat, topsoil, or other nonstructural soils, would be limited to the minimum possible distances. The location of proposed infrastructure has been guided by the existing topography, thereby minimizing alterations to the existing topography. Over-steepened slopes and excessive areas of fill have been avoided.

#### **5.1.3.1 Offshore Wharf and Trestle Structure**

As noted in Section 5.1.5.4, deep pile foundations would be required to support the high loads of the trestle and wharf. Previous geotechnical analyses had assessed geotechnical conditions of the seabed and design requirements for the trestle and wharf foundations. Lymon C. Reese & Associates (1993) reported that a number of small-diameter piles in clusters (pile groups) or a single large-diameter pile can support the trestle and wharf foundations. The depth of pile penetrations to sustain the axial loadings that would occur is expected to be approximately 60 feet or less. For large-diameter single piles, open-ended steel tube is preferred. Pile installation with a vibrator hammer should be considered.

Ben C. Gerwick, Inc. (1993) reviewed the Lymon C. Reese & Associates (1993) report and commented that pile penetration to a depth of about 80 feet would be necessary for large-diameter single piles, but this depth of penetration could be reduced with more detailed information and

analysis. Ben C. Gerwick, Inc. also concluded that installation of the piles by driving and jetting using a Vulcan 560 hammer would be reasonable.

### **5.1.3.2 Onshore Structures and Site Development**

Large, heavily loaded foundations would transfer loads to the soft, compressible glaciomarine drift. Possible design features to reduce impacts could include founding heavily loaded structures on deep foundations such as piles.

Large areas of fill and embankments would be prone to settlement resulting from consolidation of the soft clayey soil that makes up the glaciomarine drift underlying the site. As noted by GeoEngineers (1997), these settlements would occur over an extended period, with 50 to 90 percent of the total settlement occurring gradually over a period of 1 to 3 years, and remaining settlement occurring continuously over a period of many years. Therefore, preloading alone is not considered an effective option.

The clay and silty to sandy clay composing the glaciomarine drift is considered a “poor” to “bad” railway roadbed subgrade. To mitigate this condition, over-excavation of the roadbed subgrade to depths of up to 5 feet should be anticipated, with the removed surface layer replaced with properly compacted structural fill. Prior to placing the structural fill on the cut subgrade, placement of a regular or heavy-duty geotextile fabric should be anticipated to provide separation between the native subgrade and structural fill.

To minimize settlement in areas anticipated to receive fill and embankments, the design will require a number of potential mitigative strategies. Those presented below are possible alternatives that could be considered for site development. Actual mitigative measures would be determined by the project geotechnical engineer, civil engineer, and structural engineer during final design.

#### **Lightweight Fill**

Lightweight fill can consist of a variety of materials, including geof foam, lightweight aggregate, wood chips, shredded rubber tires, and other materials. Lightweight fills are used rather infrequently for large areal fills, due to relatively high costs or other disadvantages, such as the limited bearing capacity of fill-supported structures when using these materials.

#### **Subgrade Improvement**

Subgrade improvement using compacted stone columns or aggregate piers beneath the planned fill embankments can be used to minimize settlement. These methods, though, can have relatively high costs and are generally used only when placing fill embankments that support critical structures.

## **Avoidance**

Since secondary compression is expected to continue for many years, critical structures and site features should not be placed on large fill embankments. After the fill embankment is constructed, settlement would occur continuously over time, and periodic maintenance would be required to maintain planned site grades and drainage. Placement of a geogrid between the native soils and fill embankments would aid in minimizing the effects of differential settlements across the fill embankment, but it would not minimize overall settlement.

The ongoing geotechnical review will produce updated evaluation with more specific design specifications needed to construct stable pile structures.

## **5.2 UPLAND VEGETATION, WILDLIFE, AND HABITATS**

This section describes the upland biological resources in the project area and provides an assessment of potential environmental effects of the Terminal on upland vegetation, wildlife, and habitat. While the focus of this section is terrestrial biological resources, some of the species discussed utilize wetland, marine, and/or riparian habitats at times, and references to these habitats are included here. Marine and Wetland Resources are discussed in detail in Section 5.3.

This section includes an evaluation of potential effects on State Priority Habitats and Species listed by the Washington Department of Fish & Wildlife, and of federally listed species. This section also identifies potential mitigation measures designed to limit impacts. Additional details on the proposed mitigation are presented in Section 5.4.3. The information presented in this section is based on information published in the 1996 Gateway Pacific Terminal Draft EIS, literature reviews, and field investigations conducted in 2006-2010.

Key issues of concern related to upland vegetation, wildlife, and habitats include:

- Displacement of upland vegetation and habitats by Terminal infrastructure; and
- Direct mortality and disturbance to state threatened, endangered, and priority species and habitats;

### **5.2.1 Affected Environment**

This section describes existing upland biological resources in the project area, including vegetation, wildlife, habitat, and listed and protected species.

#### **5.2.1.1 *Vegetation and Habitat***

A map of vegetation communities at the Terminal is shown in Figure 5-3. Terrestrial habitat quality at the project site is generally marginal, and the habitat is fragmented into blocks of approximately

20 acres by paved roads. A number of habitat types are present at the Gateway Pacific Terminal site, including riparian communities [along Stream 1 and Stream 2 (described in Section 5.4.1)], deciduous forests, shrub communities, pasture, hayfields, and nearshore habitat, including a coastal lagoon. Terrestrial habitats are described below. The nearshore community and coastal lagoon are described in detail in Section 5.3.

Terrestrial and wetland habitats across the project area have similar vegetation in many locations. Vegetation in forested areas consists primarily of deciduous species—red alder (*Alnus rubra*) and black cottonwood (*Populus balsamifera*)—and infrequent individual western red cedar (*Thuja plicata*) or Douglas fir (*Pseudotsuga menziesii*) trees. Overall, forested stands represent several different forest management events. Generally, the oldest and largest trees are found near riparian corridors. Some small areas have tree species that were probably planted when the area had farms with yards.

Most of the forested areas have a dense understory of shrubs—vine maple (*Acer circinatum*), common snowberry (*Symphoricarpos alba*), salmonberry (*Rubus spectabilis*), Indian plum (*Oemlaria cerasiformes*), clustered rose (*Rosa pisocarpa*), and red elderberry (*Sambucus racemosa*)—and forested wetlands with red osier dogwood (*Cornus sericea*), willows (*Salix* spp.), and twinberry (*Lonicera involucrate*). Where present, the herbaceous layer is dominated by sword fern (*Polystichum munitum*), bracken fern (*Pteridium aquilinum*), and Pacific blackberry (*Rubus ursinus*). Piggyback plant (*Tolmeii menziesii*), soft rush, and slough sedge are present in the forested wetland areas.

Dense thickets of Nootka rose (*Rosa nutkana*) and Himalayan blackberry (*Rubus armeniacus*) are common along forest and pasture boundaries and roadsides. Patches of shrub wetlands are present throughout the project area and are commonly dominated by Nootka rose, Douglas spirea (*Spiraea douglasii*), and Himalayan blackberry.

Vegetation in hayfields that are seeded and hayed annually consists of grasses and forbs, including red fescue (*Festuca rubra*), bentgrass (*Agrostis* spp.), sweet vernalgrass (*Anthoxanthum odoratum*), common velvetgrass (*Holcus lanatus*), and English plantain (*Plantago lanceolata*). In less frequently managed pasture areas, dominant grass species include red fescue, meadow foxtail (*Alopecurus pratensis*), Canadian thistle (*Cirsium arvense*), bentgrass, quackgrass (*Agropyron repens*), and orchard grass (*Dactylis glomerata*). Mowing occurs annually along power-line and pipeline easements and promotes thick stands of reed canarygrass (*Phalaris arundinacea*).

Whatcom County describes riparian areas as zones where aquatic and terrestrial ecosystems interact, and include both marine and freshwater areas (Parametrix and Adolfson 2005). Riparian vegetation is important for providing habitat for fish, birds, and amphibians. Along Stream 1, especially in the reaches south of Lonseth Road (Reaches 1 and 2), riparian vegetation provides a variety of

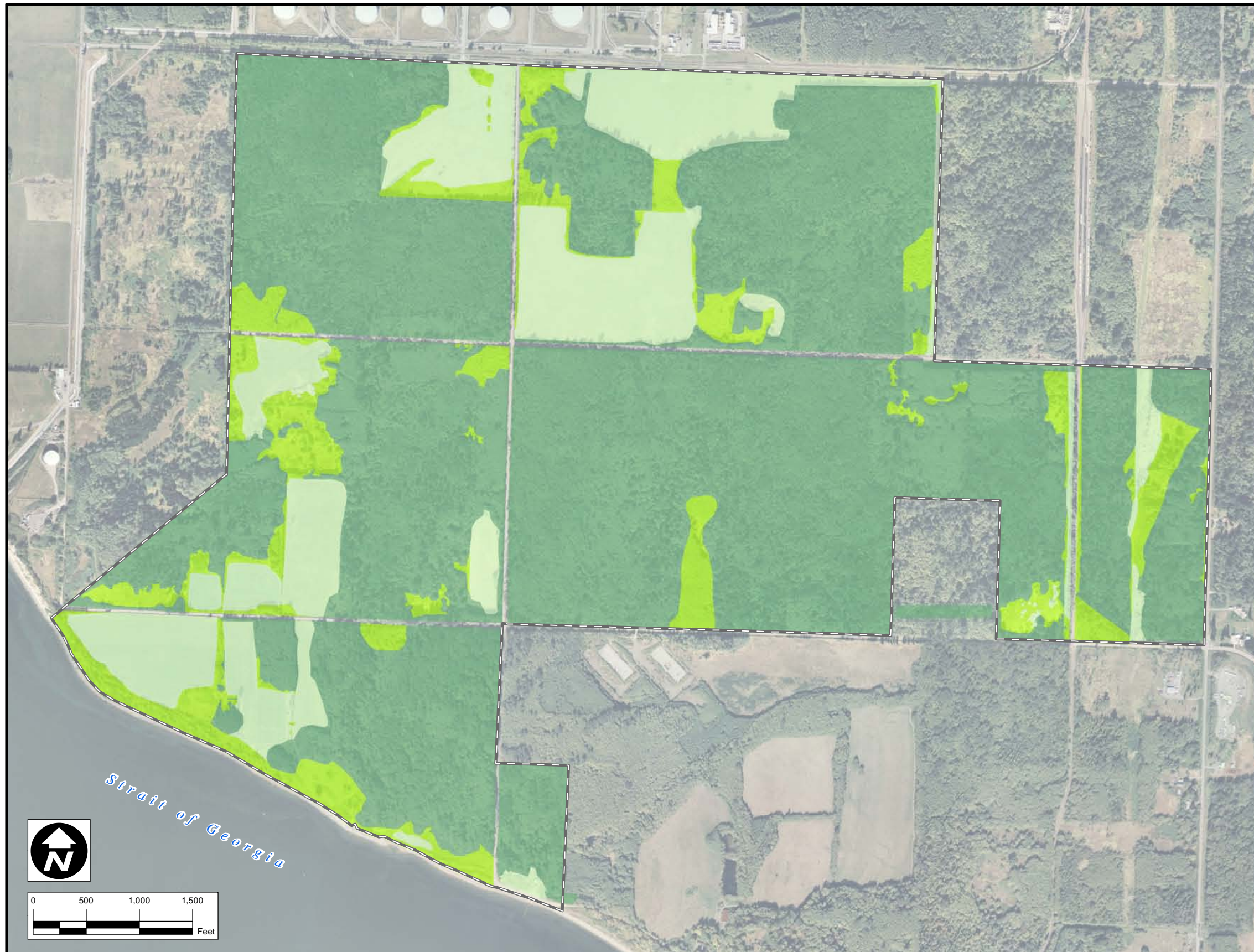

**LEGEND**

**VEGETATION TYPE:**

- EMERGENT (184.10 acres)
- FOREST (796.46 acres)
- SHRUB (115.60 acres)
- PROJECT AREA BOUNDARY

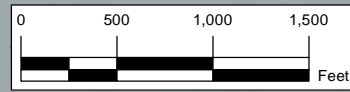

*Strait of Georgia*



CLIENT:  
**PACIFIC INTERNATIONAL TERMINALS, INC.**

DWN BY: SD  
 CHK'D BY: KD  
 DATUM: NAD83  
 PROJECTION: WA SP North, Ft.  
 SCALE: 1 inch = 1,000 feet

PROJECT:  
**PROPOSED GATEWAY PACIFIC TERMINAL**

TITLE:  
**EXISTING VEGETATION TYPES**

DATE: FEBRUARY 2011  
 PROJECT NO.: 091515338C-18-01  
 REV. NO.: 1  
 FIGURE NO.: FIGURE 5-3





habitat functions, such as shade, bank stability, sediment/nutrient filtering, and organic nutrient input. The value of riparian vegetation in the marine environment at the site is limited due to the steep bluff near the project footprint. However, the vegetation along the bluff provides habitat for birds foraging in the nearshore.

#### **5.2.1.2 Wildlife**

Terrestrial animal communities in the project area include resident and migratory birds, mammals, amphibians, and reptiles. An extensive literature search was conducted to identify the presence and abundance of terrestrial mammals, amphibians, and reptiles in the project area, and intensive field investigations were conducted in 2008 and 2009 to document the bird species that inhabit the project area.

A search of the Washington Department of Fish & Wildlife (WDFW) Priority Habitats and Species (PHS) database did not identify the potential for any federal or state recognized threatened, endangered, or priority mammal, amphibian, or reptile species to occur in the project area.

This section describes the terrestrial wildlife species that may use the project area, including birds, mammals, and amphibians and reptiles.

#### **Birds**

The Gateway Pacific Terminal site includes forest, shrub and open areas (pastures and hayfields), riparian areas, and marine/nearshore habitats suitable for a variety of bird species. Bird surveys were conducted in 2008 and 2009 to identify birds present at the project area. Birds identified included year-round resident species, seasonal migrants, and migrating birds using the site as a stopover area.

American robins were the most abundant species detected during the non-breeding season, followed by song sparrows, black-capped chickadees, and winter wrens. Song sparrows were the most abundant species detected during the breeding season, followed by American goldfinches, American robins, and savannah sparrows. Species detected most often during the surveys are habitat generalists adapted to a variety of environments and generally tolerant of human presence and other types of disturbance.

#### ***Migratory Birds***

The Migratory Bird Treaty Act (MBTA) of 1918 (16 U.S.C. 703-712 §703) established federal responsibility for the protection of nearly all species of migratory birds, their eggs, and nests. A migratory bird is any species or family of birds that live, reproduce, or migrate within or across international borders at some point during their annual life cycle.

Under the MBTA, it is illegal to “take” migratory birds, their eggs, feathers, or nests. The MBTA defines “take” to include any attempt at hunting, pursuing, wounding, killing, possessing, or transporting any migratory bird, nest, egg, or part thereof. More than 800 species of migratory birds are currently protected under the MBTA. Protection of nests by the MBTA includes only nests with eggs and/or young (USFWS 2008).

Barn swallows, brown-headed cowbird, common yellowthroat, harlequin duck, olive-sided flycatcher, orange-crowned warbler, Pacific-slope flycatcher, red-breasted merganser, rufous hummingbird, savannah sparrow, Swainson’s thrush, and warbling vireo were observed in a variety of habitats in the project area during the breeding season, and were presumed to be breeding in the project area (Table 5-3). Western tanagers and Swainson’s thrush were limited to riparian areas; warbling vireo were limited to forested areas; common yellowthroat were limited to shrub areas; and barn swallows and brown-headed cowbirds were limited to the hayfield adjacent to the shoreline.

### ***Non-migratory Birds***

A list of non-migratory birds identified during field surveys is provided in Table 5-4. The number of individual birds detected for some year-round resident species, such as American goldfinches, olive-sided flycatcher, orange-crowned warbler, Pacific-slope flycatcher, rufous hummingbird, and savannah sparrow, were higher during the breeding season than during the non-breeding season. This is likely the result of either an increased abundance of birds during the breeding season where suitable breeding habitat exists, or higher rates of detection due to increased bird vocalizations associated with breeding.

Non-migratory birds were generally present in all habitats in the project area, with a few exceptions. Northern harrier were found only in riparian areas; golden crowned kinglets, hairy woodpecker, Hutton’s vireo, pileated woodpecker, and red-winged blackbird were identified in the forests; merlins were only found in shrub communities; Cooper’s hawk and red-tailed hawk were observed in the pasture and hayfields; and pelagic cormorants were found in the nearshore.

### **Amphibians and Reptiles**

Although frequent rain and the mild climate of the Pacific Northwest create an excellent environment for amphibians, the local habitats on the project site are limited in their suitability to many amphibian species. Based on range and distribution maps, 10 species of amphibians could occur near and within the proposed Gateway Pacific Terminal site. Many of the species are associated with mature and old growth coniferous forests that provide downed logs and other debris for abundant hiding cover (Nussbaum, et al. 1983, Leonard, et al. 1993). The absence of old-growth forests in the project area reduces the number of species that may occur at the site. Because most of the site is vegetated by young deciduous forest, pastures, and hayfields, and because the site lacks large woody debris on

**Table 5-3 Migratory Bird Species Identified in the Project Area**

<b>Common name</b>	<b>Scientific name</b>	<b>Migratory status</b>	<b>Habitat Type</b>
barn swallow	<i>Hirundo rustica</i>	Breeding	Hayfield (bluff above nearshore)
Barrow's goldeneye	<i>Bucephala islandica</i>	Non-Breeding	Hayfield (bluff above nearshore), Nearshore
brown-headed cowbird	<i>Molothrus ater</i>	Breeding	Hayfield (bluff above nearshore)
common goldeneye	<i>Bucephala clangula</i>	Non-Breeding	Nearshore
common loon	<i>Gavia immer</i>	Non-Breeding	Nearshore
common yellowthroat	<i>Geothlypis trichas</i>	Breeding	Shrub
cormorant species	<i>Phalacrocorax spp.</i>	Migratory	Hayfield (bluff above nearshore), Nearshore
harlequin duck	<i>Histrionicus histrionicus</i>	Breeding	Hayfield (bluff above nearshore), Nearshore
herring gull	<i>Larus argentatus</i>	Non-Breeding	Nearshore
horned grebe	<i>Podiceps auritus</i>	Non-Breeding	Hayfield (bluff above nearshore), Nearshore
loon species	<i>Gavia spp.</i>	Migratory	Hayfield (bluff above nearshore), Nearshore
olive-sided flycatcher	<i>Contopus cooperi</i>	Breeding	Hayfield (bluff above nearshore), pasture, Shrub
orange-crowned warbler	<i>Vermivora celata</i>	Breeding	Pasture, Riparian, Shrub
Pacific-slope flycatcher	<i>Empidonax difficilis</i>	Breeding	Pasture, Riparian, Forest, Shrub
red-breasted merganser	<i>Mergus serrator</i>	Breeding	Nearshore
ruby-crowned kinglet	<i>Regulus calendula</i>	Non-Breeding	Riparian, shrub
rufous hummingbird	<i>Selasphorus rufus</i>	Breeding	Pasture, Riparian, Forest
savannah sparrow	<i>Passerculus sandwichensis</i>	Breeding	Hayfield (bluff above nearshore), Nearshore, Pasture, Shrub
surf scoter	<i>Melanitta perspicillata</i>	Non-Breeding	Nearshore
Swainson's thrush	<i>Catharus ustulatus</i>	Breeding	Riparian
unidentified gull	<i>Laridae family</i>	Migratory	Hayfield (bluff above nearshore), Nearshore, Pasture, Riparian, Forest
warbling vireo	<i>Vireo gilvus</i>	Breeding	Forest
western grebe	<i>Aechmophorus occidentalis</i>	Non-Breeding	Nearshore
western tanager	<i>Piranga ludoviciana</i>	Breeding	Riparian
willow flycatcher	<i>Empidonax traillii</i>	Breeding	Shrub
Wilson's warbler	<i>Wilsonia pusilla</i>	Breeding	Pasture
yellow warbler	<i>Dendroica petechia</i>	Breeding	Pasture, Riparian, Forest
yellow-rumped warbler	<i>Dendroica coronata</i>	Breeding	Hayfield (bluff above nearshore), Pasture, Riparian

**Table 5-4 Non-Migratory Bird Species Identified During Field Investigations**

<b>Common name</b>	<b>Scientific Name</b>	<b>Habitat Type</b>
American crow	<i>Corvus brachyrhynchos</i>	Nearshore, Riparian, Forest
American goldfinch	<i>Carduelis tristis</i>	Nearshore, Pastures, Riparian, Forest, Shrub
American robin	<i>Turdus migratorius</i>	Forest, Shrub
Anna's hummingbird	<i>Calypte anna</i>	Upland meadow (bluff above nearshore), Forest
bald eagle	<i>Haliaeetus leucocephalus</i>	Hayfield (bluff above nearshore), Nearshore, Pastures, Riparian, Shrub
Bewick's wren	<i>Thryothorus ludovicianus</i>	Hayfield (bluff above nearshore), Pastures, Forest, Shrub
black-capped chickadee	<i>Poecile rufescens</i>	Pastures, Riparian, Forest, Shrub
brown creeper	<i>Certhia americana</i>	Pastures, Riparian, Forest
bush tit	<i>Psaltriparus minimus</i>	Pastures
chestnut-backed chickadee	<i>Poecile rufescens</i>	Pastures, Riparian, Forest, Shrub
Cooper's hawk	<i>Accipiter cooperii</i>	Hayfield
dark-eyed junco	<i>Junco hyemalis</i>	Nearshore, Forest, Shrub
golden-crowned kinglet	<i>Regulus satrapa</i>	Forest
great blue heron	<i>Ardea herodias</i>	Hayfield (bluff above nearshore)
hairy woodpecker	<i>Picoides villosus</i>	Forest
Hutton's vireo	<i>Vireo huttoni</i>	Forest
marsh wren	<i>Cistothorus palustris</i>	Hayfield, Riparian
merlin	<i>Falco columbarius</i>	Shrub
mourning dove	<i>Zenaida macroura</i>	Hayfield (bluff above nearshore), Nearshore, Shrub
northern flicker	<i>Colaptes auratus</i>	Hayfield (bluff above nearshore)
northern harrier	<i>Circus cyaneus</i>	Riparian
pelagic cormorant	<i>Phalacrocorax pelagicus</i>	Nearshore
pileated woodpecker	<i>Dryocopus pileatus</i>	Forest
pine siskin	<i>Carduelis pinus</i>	Riparian, Forest, Shrub
red-tailed hawk	<i>Buteo jamaicensis</i>	Pastures
red-winged blackbird	<i>Agelaius phoeniceus</i>	Forest
song sparrow	<i>Melospiza melodia</i>	Hayfield (bluff above nearshore) , Riparian, Forest
spotted towhee	<i>Pipilo maculatus</i>	Riparian, Forest
western gull	<i>Larus occidentalis</i>	Hayfield (bluff above nearshore), Nearshore
winter wren	<i>Troglodytes troglodytes</i>	Riparian, Forest, Shrub

the ground for refugia, habitat for amphibians is limited. Wetland areas throughout the site provide the most potential habitat for breeding and rearing of pond-breeding amphibians that may also utilize shallow inundation, such as the northwestern salamander (*Ambystoma gracile*) and Pacific treefrog (*Pseudacris regilla*).

Field investigations conducted in 1993 identified four species of amphibian (two species of salamander, and two species of frog) and one species of reptile, as well as large numbers of *Ranid* and treefrog tadpoles. Two species of salamander observed at the project site, the northwestern salamander and the long-toed salamander (*Ambystoma macrodactylum*), are widespread in western Washington, and occur from sea level to over 6,000 feet in elevation (Leonard et al. 1993). Both the northwestern salamander and the long-toed salamander are pond breeders that commonly use subterranean refugia during summer and cold winter periods (Leonard et al. 1993).

Similarly, two species of frog, the red legged frog (*Rana aurora*) and the Pacific treefrog (*Pseudacris regilla*), were observed at the site, and are common in Washington State. Red-legged frogs occur primarily in terrestrial habitat, while the Pacific treefrog uses a wide range of habitats and can be found in ponds, woodlands, pastures, and meadows. Both species use inundated areas for breeding, where eggs are attached to submerged emergent vegetation.

Six additional amphibian species could possibly occur in the project vicinity. However, most of these species are not likely to be common to the area. Two species, the Pacific giant salamander (*Dicamptodon tenebrosus*) and western redback salamander (*Plethodon vehiculum*), are most commonly found in pure conifer forest habitat, which does not occur on the project site. The ensatina (*Ensatina eschscholtzii*) most commonly occurs under bark or other wood debris associated with mature forest habitat, which is lacking in the project area. The western toad frog may possibly occur on the site, because it is commonly found near marshes and small lakes, but it also can be found in terrestrial habitats (Leonard et al. 1993; Nussbaum et al. 1983). The rough-skinned newt (*Taricha granulose*) may occur in the project area but was not identified during field investigations. The rough-skinned newt may be found in shallow water habitats and lay eggs on submerged vegetation. It is possible the newt inhabits areas adjacent to the coastal lagoon. The bullfrog (*Rana catesbeiana*), an introduced exotic species, is highly aquatic. If it occurs on the site, it would also likely be limited to the coastal lagoon at the mouth of Stream 1.

The one species of reptile identified during field investigations was the western terrestrial garter snake. The garter snake generally inhabits grassy or shrubby areas on the edges of water bodies. Individuals may be found in wetland areas, as well as stream edges, ponds, shrub areas and lakes (Hallock and McAllister 2009).

None of the amphibians or reptiles observed at the site, or those possibly occurring on the project site, are listed as sensitive, threatened, or endangered by WDFW or the USFWS.

## **Mammals**

Terrestrial mammals likely to occur at the Gateway Pacific Terminal site include those species typical of urban open-space. Raccoon, eastern gray squirrel, black-tailed deer, and coyote were all identified during various field investigations.

## **Federally Listed Threatened and Endangered Species**

No upland species federally listed as threatened or endangered use the project area. Marbled murrelets may use the offshore portion of the site for foraging. A more detailed analysis of these issues will be provided in a forthcoming Biological Evaluation.

Gray wolves are a federally listed threatened species under USFWS jurisdiction. Whereas occasional sightings of grey wolves have been reported in the state, no breeding pairs or packs of wolves are currently documented in the State of Washington. The Whatcom County Critical Areas Ordinance, Best Available Science Review describes gray wolves as rare visitors to North Cascades National Park. Sightings in the project vicinity reported by WDFW are likely to have involved lone wolves straying from Canada or wolf/dog hybrids that have been released into the wild (Parametrix and Adolfson 2005).

## **State Priority Habitats and Species**

This section identifies the State priority habitats and species that potentially use the project site. The WDFW Priority Habitats and Species (PHS) database identifies several bird species that inhabit the site area as state priority species.

Seven priority species were observed during field investigations conducted in 2008-2009 (Table 5-5).

None of the State Priority Species identified in the project area are listed as threatened or endangered by state or federal regulatory agencies. The only migratory State Priority Species identified during the breeding season was the harlequin duck. No nests were identified during the field investigation.

Four nearshore species (common loon, western grebe, great blue heron, and harlequin duck) and bald eagle use the Project Area for foraging in the marine environment. Bald eagles were identified perched on the bluffs above the nearshore area searching for potential prey, and roosting in trees above the nearshore.

**Table 5-5 WDFW Priority Species that may occur in Whatcom County**

Common Name	Scientific Name	State Status	Federal Status	Habitat Type on-site
Common loon	<i>Gavia immer</i>	Sensitive	None	Nearshore
Western grebe	<i>Aechmophorus occidentalis</i>	Candidate	None	Nearshore
Great blue heron	<i>Ardea herodias</i>	None	None	Nearshore
Harlequin duck	<i>Histrionicus histrionicus</i>	None	None	Nearshore
Bald eagle	<i>Haliaeetus leucocephalus</i>	Sensitive	Species of Concern	Bluff above the nearshore and riparian areas
Merlin	<i>Falco columbarius</i>	Candidate	None	Shrub communities
Pileated woodpecker	<i>Dryocopus pileatus</i>	Candidate	None	Riparian and Hayfield

Source: WDFW 2010

Merlin were identified in shrub communities and pileated woodpeckers were identified in forested communities, primarily in the riparian corridor, and in hayfields and pastures.

A great blue heron nesting rookery is located approximately 1 mile north of the proposed project site, east of Birch Bay State Park (WDFW 2005). Studies conducted by BP indicate that foraging areas for great blue heron include marine shorelines, intertidal zones, wetlands, streams, riparian areas, and upland fallow fields. The most concentrated foraging during the nesting season occurs in the intertidal areas nearest the colony (WDNR 2010), north of Point Whitehorn, approximately 1.5 miles from the proposed Terminal.

## 5.2.2 Potential Effects on Upland Vegetation, Wildlife, and Habitat

This section describes the potential effects of the proposed Terminal on upland vegetation, wildlife, and habitats.

### 5.2.2.1 Construction Related Effects

Construction may affect upland vegetation, wildlife, and habitats through changes to the surface and vegetation, construction noise, and other effects. This section describes the effects of construction on upland vegetation, wildlife, and habitats.

### Vegetation and Habitat

Construction of the Terminal would remove vegetation and soil from the project footprint. It is anticipated that the conversion of vegetation communities would be permanent. Temporary vegetation disturbance would occur in an area estimated to be 20 feet beyond the final footprint to allow maneuvering during construction. This area would be restored following construction.

Vegetation communities that would be displaced by project construction include 224 acres of forested habitat, 36 acres of shrub habitat, and 69 acres of pasture and hayfields (Figure 5-4). Potential impacts of the Terminal on wetlands are described in Section 5.4.

No federal or state endangered, threatened, or sensitive plant species occur within the onshore portions of the Terminal, and therefore none would be affected by construction of the proposed project.

Loss of vegetation would affect all species using the vegetation as habitat. The effects of the project, and loss of vegetation on wildlife, are described below.

### **Wildlife**

Construction of the Gateway Pacific Terminal would result in direct habitat loss as described above. Indirect effects would include increased fragmentation by rail embankments and other project infrastructure. Impacts to habitat would displace wildlife species that currently depend on the habitat. It is assumed that most mobile wildlife species, such as birds and larger mammals, would move away from areas of disturbance and would colonize nearby suitable habitats. However, it is possible that nearby habitats would not be able to satisfy the needs of additional animals, resulting in the loss of some individuals. Most small mammals, amphibians, and reptiles would be directly affected by construction due to limited mobility, resulting in a loss of some individuals of these species.

Most of the bird species identified during field investigations appear to be habitat generalists, using a variety of the habitat types that occur on site, with some exceptions, as described in Section 5.2.1. Species using exclusively the riparian community associated with the lower reaches of Stream 1 (migrating western tanagers and Swanson's thrush and resident northern harrier) are not likely to be affected by construction of the terminal, as no construction activities would occur in the riparian corridor.

Bird species using portions of the project area that would be directly affected by construction would likely be temporarily or permanently displaced due to the loss and/or alteration of breeding and foraging habitats and increased habitat fragmentation. Specifically, species using the hayfield above the nearshore community (Barrow's goldeneye, common goldeneye, common loon, harlequin duck, herring gull, horned grebe, loon species, red-breasted merganser, western grebe, great blue heron, and western gull) would likely be temporarily displaced during construction due to noise and general disturbance. These species are expected to resume use of the area following construction.





Abandonment of nesting sites and the loss of eggs or young could also occur, especially by birds nesting in the forested community during clearing of the site. Seventeen species of migratory birds





**LEGEND**

**VEGETATION IMPACT AREA (329.19 acres):**

	EMERGENT (74.61 acres) (Permanent: 64.59 acres) (Temporary: 10.02 acres)
	FOREST (215.95 acres) (Permanent: 189.82 acres) (Temporary: 26.13 acres)
	SHRUB (38.63 acres) (Permanent: 34.38 acres) (Temporary: 4.25 acres)
	UNVEGETATED
	PROJECT AREA BOUNDARY

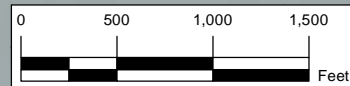

*Strait of Georgia*



CLIENT:  
**PACIFIC INTERNATIONAL TERMINALS, INC.**

DWN BY: SD  
CHK'D BY: KD  
DATUM: NAD83  
PROJECTION: WA SP North, Ft.  
SCALE: 1 inch = 1,000 feet

PROJECT:  
**PROPOSED GATEWAY PACIFIC TERMINAL**

TITLE:  
**VEGETATION IMPACTS: PROPOSED ACTION**

DATE: FEBRUARY 2011  
PROJECT NO.: 091515338C-18-01  
REV. NO.: 1  
FIGURE NO.: FIGURE 5-4



were identified in the Terminal project area during the breeding season (Table 5-3). Although nesting birds were not recorded, it is possible that any of these species could be nesting in the project area, and would be disturbed if construction were to occur during the nesting season.

Effects on mammals would include the loss and/or alteration of breeding and foraging habitats and increased habitat fragmentation. Mortality would likely also occur to less mobile species.

The proposed project would displace 12,814 linear feet of streams and ditches that could provide habitat for amphibians, although these are either in pastures or roadside drainages and do not have high quality habitat.

### ***Federally Listed Threatened and Endangered Species***

No federally listed Threatened or Endangered mammal, amphibian, or reptile species would be displaced by the Terminal.

### ***State Priority Habitats and Species***

Effects of the construction of the Terminal on common loon, western grebe, great blue heron, and harlequin duck would be similar as those described for marbled murrelets in the marine resources section (Section 5.3). These species would likely be disturbed during construction of the terminal.

Bald eagles were identified as primarily using the bluffs above the nearshore area and the riparian area of the lowest reach on Stream 1. Bald eagle nesting sites would not be displaced by the proposed Terminal, including the trestle; however, construction noise would likely displace bald eagles roosting along the bluff to alternative roosting sites.

Merlin were identified primarily in shrub communities. It is possible that merlin would be displaced during construction of the proposed project. However, similar existing habitat at the Gateway Pacific Terminal project site would not be disturbed during development, and this would likely provide adequate alternative habitat away from the proposed project footprint.

Ultimately, the project would result in a net improvement in habitat for pileated woodpecker and other species using the riparian corridor. Pileated woodpeckers were identified in a pasture area and in the riparian area of Stream 1's lowest reach. No Terminal construction activities would occur within the riparian area. Restoration activities in the riparian area are proposed as part of the overall Terminal mitigation plan to improve habitat. Although a single pileated woodpecker was identified in a pasture area, it is presumed that that the pasture does not provide primary habitat for the woodpecker because pileated woodpeckers typically inhabit forested areas.

The nearshore bird species (common loon, western grebe, great blue heron, and harlequin duck) that may use the project site for foraging in the marine environment would also likely be displaced during construction, with effects similar to those described for marbled murrelets in the Marine Resources section (Section 5.3). None of the nearshore bird species were identified nesting in the project area during the 2008-2009 bird surveys, so breeding is not anticipated to be disturbed.

### **5.2.2.2 Operational Effects**

This section describes effects that could potentially arise due at the Terminal due to operational activities, such as commodities handling.

#### **Vegetation and Habitat**

Other than the aforementioned construction-related effects, operation of the Terminal would not affect existing vegetation communities. Long-term vegetation maintenance plans would be developed along with the proposed wetland mitigation and facilities maintenance plans.

#### **Wildlife**

Operation of the proposed project is not anticipated to affect bird, terrestrial mammal, or amphibian species adversely. Wildlife species have coexisted with the adjacent BP Cherry Point Refinery for over 30 years and a similar response is anticipated for the proposed project.

#### **Federally Listed Threatened and Endangered Species**

No federally listed upland Threatened or Endangered species would be affected by the operation of the Terminal. A more detailed analysis of these issues will be provided in a forthcoming Biological Evaluation.

#### **State Priority Habitats and Species**

As described above, it is anticipated that the priority species identified in the project area would be displaced during construction. Bald eagles displaced during construction would be unlikely to return to their nesting sites once they are displaced and would instead find new, alternative nesting sites. Merlin displaced during construction may continue to use the Terminal area after construction or may occupy new habitat at proposed wetland mitigation sites or elsewhere. The pileated woodpeckers identified in the project area would likely continue to use the Terminal site after construction, especially the restored riparian corridors. The nearshore birds identified using the Project area (common loon, western grebe, great blue heron, and harlequin duck) would be predicted to resume foraging in the marine environment once facility construction was complete and operation of the facility began.

### 5.2.3 Proposed Design Features Intended to Reduce Impacts

Impacts to songbird breeding and foraging habitat would be mitigated at the proposed wetland mitigation sites (refer to Section 5.4 for details). The need to preserve and improve existing priority habitats for birds was identified as a primary objective of the Terminal wetland mitigation design, and mitigation areas within the Terminal property were selected and designed to expand upon and/or protect priority habitats, especially riparian areas.

Compensatory mitigation would provide a new habitat type on-site with the construction of a 36-acre open water area in the north “hoop” of the East Loop. Currently there is no open water or lacustrine fringe habitat in the project area. The proposed pond is needed to ensure hydraulic functions, however the area would likely provide habitat suitable for a variety of waterfowl, including many migratory species that are commonly seen utilizing the nearby Lake Terrell.

If land clearing were to occur during the breeding season, a qualified biologist would first survey the affected area. If field surveys identified nests, or if other evidence of nesting were observed, a protective buffer (the size depending on the habitat requirements of the species) would be delineated, and the entire buffer area would be avoided to prevent destruction or disturbance to nests until the nests are no longer active.

## 5.3 MARINE RESOURCES

The proposed Terminal would be located in an industrial area along the marine waterfront, and would include a marine trestle and wharf that would be constructed in the nearshore environment. The marine trestle and wharf could have potential effects on marine resources during both construction and operation.

The Cherry Point area is recognized by the State of Washington as an aquatic reserve, with an environment that balances multiple unique features, including important natural habitats and deepwater access for industrial use. The herring stock found there has supported important commercial fisheries in the past and is an important resource for local Native American Tribes. The Cherry Point nearshore area also supports other fish species, marine mammals, and marine birds.

### 5.3.1 Affected Environment

This section describes the existing marine environment at the Gateway Pacific Terminal site. A more detailed analysis of the proposed Terminal on threatened and endangered and priority species will be provided in the forthcoming Biological Evaluation. Key resources include the marine habitat and characteristic species, including salmon and herring. This section begins with a description of the nearshore marine physical processes, since the physical structure plays a key role in shaping habitat for marine biota.

### **5.3.1.1 Marine Physical Process and Bathymetry**

Oceanographic features, such as waves, currents, and sediment transport, characterize physical conditions of the habitat. Westmar Consultants, Inc. (Westmar 1996) developed preliminary data on key physical characteristics of the nearshore marine environment at the site. A follow-up study is currently underway to generate additional data on physical conditions; these data will be used to refine the engineering design of the wharf.

Currents at the project site include both wind- and wave-induced currents, and tidal currents in deeper water. Tidal currents near the project area range from 0.7 to 1.0 feet per second (ft/sec) flowing to the northwest during flood tide and to the southeast during ebb tide. Wind-induced currents include a drift current in the direction of wind waves. In addition, waves approaching the shoreline give rise to a longshore current parallel to shore (Westmar 1996).

Sediment at the beach near the project area consists of cobble overlying gravel and coarse sand. Sediment characteristics in deeper water [below -13 feet relative to mean lower low water (MLLW)] are dominated by sand and mud (Shapiro & Associates 1996). Because of the relatively large sediment sizes at the site, sediment transport tends to occur as bedload (rolling, sliding, or bouncing along the bottom) rather than as sediments suspended in the water (Westmar 1996). Most open ocean beaches undergo seasonal changes due to changes in swell conditions. During calm conditions typical of the summer months, wave action moves sediment shoreward to build up the beach face. During storm activity typical of the winter months, the beach profile is generally lowered as sand is moved offshore to a bar that forms near the breaker zone. In addition, the longshore current causes a general movement of sand parallel to the beach. This movement of sediment transported by the longshore current is termed *littoral drift*.

The bathymetry along the Cherry Point shoreline in the proposed project area is unique in that it provides water depths of more than 70 feet relatively close to shore, thereby allowing access for large vessels without the need to dredge shipping channels or berthing areas. Nearshore water depths within the project vicinity range from 0 to -100 feet below MLLW.

### **5.3.1.2 Marine Biological Communities**

The nearshore marine community is unique in providing direct functional interaction between upland and marine habitats. In this document, the nearshore marine community is defined as the transition from uplands habitat to marine habitat in waters to a depth of -30 feet relative to MLLW. This depth is the deepest water depth where sufficient light penetrates to support photosynthesis, and is known as the *photic zone*. Nearshore marine communities are classified by depth or *vertical zonation* (Figure 5-5). These classifications consist of:

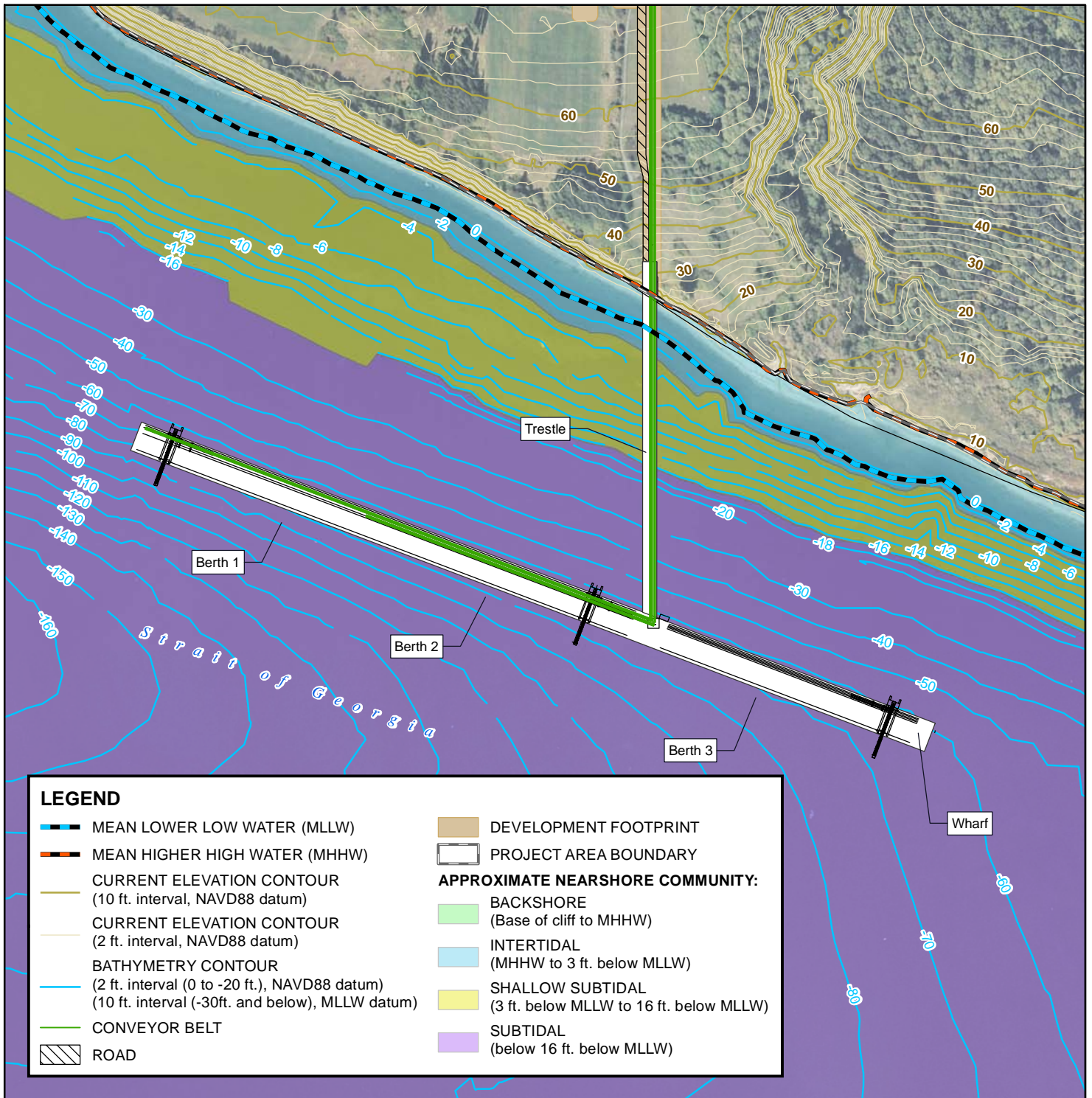

Source:  
 Ausenco Sandwell, 154199-A100-42S01.dwg (Rev. I), 12/09/2010.  
 David Evans & Associates, 2010-04-14-svTPXpiti0006-DEGROSS.dwg, 07/20/2010.  
 David Evans & Associates, svEM01-Bathymetric-Tidelands.dwg, 09/17/2010.

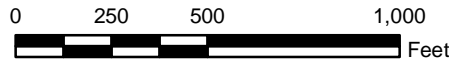

				CLIENT: <b>PACIFIC INTERNATIONAL TERMINALS, INC.</b>	
PROJECT: <b>PROPOSED GATEWAY PACIFIC TERMINAL</b>		DWN BY: SD	DATUM: NAD83	DATE: FEBRUARY 2011	
TITLE: <b>EXISTING CONDITIONS          NEARSHORE COMMUNITIES</b>		CHK'D BY: KD	REV. NO.: 1	PROJECT NO.: 091515338C-18-01	
		PROJECTION: WA SP North, Ft.	SCALE: 1 inch=500 feet	FIGURE No.: <b>FIGURE 5-5</b>	





1. the backshore (supralittoral) zone extending from the base of the bluffs to the mean higher high water (MHHW) mark;
2. the intertidal (eulittoral) zone, from MHHW to -3 feet below MLLW;
3. the shallow subtidal zone, from -3 feet to -16 feet below MLLW; and
4. the deep subtidal zone, below -16 feet below MLLW (Figure 5-5).

The proposed Terminal footprint extends into all of these classes of nearshore community. The project area also includes a coastal lagoon south of the proposed development footprint.

### **The Backshore**

The shoreline in the vicinity of the project area is characterized by mostly flat to gently sloping terrain on the uplands with steep bluffs bordering the westernmost 2,500 feet of beach. Only extreme storm-driven tides inundate the backshore. Wood accumulates in the backshore through transport at extreme high tides. The woody debris that accumulates along the shoreline in the project area helps to stabilize the shoreline and provides microhabitats for invertebrates and birds.

A portion of the backshore at the project area, west of Gulf Road is characterized as a coastal lagoon (11.17 acres), which is a “shallow coastal water body separated from the ocean by a barrier, connected at least intermittently to the ocean by one or more restricted inlets” (Kjerfve 1994). Coastal lagoons are formed and maintained through sediment transport processes. Sediment carried by rivers, waves, currents, wind, and tides accumulates in river and tidal deltas, on marshes and flats where submerged aquatic vegetation slows currents, and on washover fans. Lagoon barriers are constantly eroded by waves and wind, requiring continuous sediment deposition to maintain them (Bird 1994).

Coastal lagoons are highly productive ecosystems. They contribute to the overall productivity of coastal waters by supporting a variety of habitats, including salt marshes and sea grasses, and they provide habitat for fish and shellfish species. Because of the low flushing rate of the lagoon, it may be a favorable habitat for primary producers such as phytoplankton and aquatic plants. Furthermore, nutrients are transported to lagoons from surface water and groundwater flows and through exchange with the ocean. Because nutrient availability often limits primary productivity, coastal lagoons can foster high rates of primary production, thereby supporting high rates of secondary production compared to other aquatic ecosystems (Nixon 1995).

The coastal lagoon within the project area serves as nursery and feeding habitats for a variety of organisms (Heck and Thoman 1984). Vegetation includes emergent vegetation adapted to brackish conditions, including fat-hen saltbush, saltgrass, pickleweed, salt marsh dodder, arrowgrass, and

Pacific silverweed. Other species present include Sitka spruce, Douglas spirea, and Nootka rose. The coastal lagoon has salt-affected, organic-rich soils.

### **The Intertidal Community**

The intertidal community includes those species that live between the low and high tide lines (MHHW to -3 feet MLLW). At low tide, the intertidal zone is exposed whereas at high tide, the intertidal zone is underwater. Organisms living in the intertidal zone have a highly variable environment and have evolved various adaptations specific to these conditions. The intertidal community is characterized by vertical zonation, where the community is divided into distinct bands of species at different levels along the shore.

The intertidal community in the project area is described as a rocky intertidal community in that the shoreline has a hard bottom substrate, with a species community and distribution that is influenced by behavioral, morphological, or physiological adaptations (Somero 2002). The rocky shoreline at the project site has substantial wave action, and species have evolved adaptations to allow individuals to cling tightly to the rocks. Additionally, organisms living in the high intertidal zone must cope with a large range of temperatures. While organisms are underwater during high tide, temperatures vary little; however, when organisms are exposed to the elements at low tide temperatures may dip to below freezing or become extremely hot for a few hours. While mobile organisms, such as crabs, snails, and worms, can avoid temperature fluctuations by moving into cool, moist refuges during low tide (under rocks, etc.), sessile organisms, such as mussels and anemones, are dependent on coping mechanisms. Finally, the intertidal community is characteristically limited in terms of space, resulting in intense competition among species for attachment and refuge substrates.

Shapiro & Associates (now AMEC Earth & Environmental, Inc. [AMEC]) surveyed macroalgae along the existing shoreline of the project area on two occasions, including an aerial survey in 2005 and a detailed macroalgae distribution survey conducted in the 1990s. In 2007, AMEC biologists qualitatively assessed the nearshore habitat, including snorkel surveys, to plan the macroalgae habitat enhancement site that is proposed to mitigate nearshore habitat impacts. In general, the species community was consistent with conditions reported from 1992 to 1993 (Shapiro & Associates 1996).

Shapiro & Associates (1996) reported that marine vegetation in the upper intertidal zone between +2 and -2 feet MLLW is dominated by *Ulva* sp. and *Porphyra* sp., with a narrow band of *Fucus* and *Gigartina* between -2 and -3 feet MLLW. Below -2 feet MLLW, kelp beds are characterized by a diverse assemblage of red and brown algae, such as *Sargassum* sp., *Cryptopleura* sp., *Laminaria* sp., *Neriocystis* sp., and *Iridaea* sp.

The invasive brown alga, *Sargassum muticum*, colonizes cobble and rocky substrates in lower intertidal and shallow subtidal habitats of Cherry Point. The rapid growth of this alga, along with its ability to reproduce in a single season, allows it to establish itself quickly. Once established, *Sargassum* reduces abundance of native algae by shading. Since being introduced to Whatcom County waters less than 50 years ago, *Sargassum muticum* is now present on more than one-third of the County's shoreline. Observations in the Birch Point and Cherry Point areas have shown continued expansion in the range of *Sargassum muticum* (Kyte 2004).

Sparse to dense patches of eelgrass are located at depths of about -3 to -5 feet MLLW in the project area. A sparse patch of eelgrass was observed in the 1990s, beginning more than 50 feet west of the centerline of the proposed Gateway Pacific Terminal trestle (where sparse is defined as no more than 8 stems per 0.25 meter) (Shapiro & Associates 1996). The patch became dense at a distance of 75 to 100 feet west of the centerline of the proposed trestle. During more recent investigations, no eelgrass was identified near the proposed trestle (AMEC unpubl. data). During recent field investigations, the eelgrass bed nearest to the proposed Terminal occurred to the north, several hundred feet south of the BP Cherry Point Refinery pier. As required under the Settlement Agreement (1999), a macroalgae and eelgrass investigation will be completed within 2 years of trestle and wharf construction to confirm site conditions.

No eelgrass is present in the area that would be under the proposed wharf, as the water is too deep to support an eelgrass community. Previous studies conducted in Puget Sound have reported the maximum depth of eelgrass as -21.3 feet MLLW (Gaeckle 2009).

The intertidal community also includes organisms living on or under the bottom sediments. These organisms constitute the benthic fauna or *infauna*. Annelid worms, burrowing anemone, amphipods, and a variety of clams—including those sought after by recreational clam diggers, such as cockles, native littleneck, and butter clams—dominate the intertidal infauna at the Terminal site.

### **Shallow Subtidal Community**

The Shallow subtidal community (ranging from -3 to -16 feet MLLW) in the project area is characterized by kelp beds that provide a unique three-dimensional habitat for marine organisms. Kelp beds in the project area are composed primarily of brown alga belonging to the taxonomic order Laminariales. Kelp is considered the fastest growing organism in the world. During the summer, kelp beds throughout Puget Sound can increase in length up to about 3 inches per day and produce approximately 20 pounds of biomass per square yard in 3 months (Thom 1981). Kelp beds provide important refuge habitat for a number of fish species, especially rockfish. Juvenile and sub-adult salmon have also been known to use kelp bed habitats.

## **The Subtidal Community**

Below -16 feet MLLW, the substrate is dominated by sand and mud and provides limited ecological diversity. Diver surveys conducted in 1992 to 1993 revealed that no algae are found below -16 to -20 feet MLLW, the depth zone that marks the beginning of the sand and mud substrate (Shapiro & Associates 1996).

Subtidal invertebrates characteristic of the Cherry Point reach include seastars, red rock crabs, small shrimp, and infauna species, such as polychaetes and small clams (EVS 1999). The deeper soft mud habitat is characterized by a sparse epifauna, which includes the sea pen, nudibranchs, Dungeness and Tanner crabs, and small crangonid shrimp. The infauna is dominated by small sea cucumbers, as well as polychaetes, bivalves, burrowing anemones, and brittle stars.

*Groundfish* are fish species that live on, in, or near the seafloor. Groundfish that utilize Cherry Point include Dover sole (*Solea solea*), English sole (*Parophrys vetulus*), rock sole (*Lepidopsetta bilineata*), starry flounder (*Platyichthys stellatus*), and Pacific and speckled sanddabs (*Citharichthys sordidus* and *C. stigmaeus*, respectively). Occasionally adult butter sole (*Isopsetta isolepsis*) have been found, along with lingcod (*Ophiodon elongates*) (Smith and Shull 2009). During the juvenile phase of their lives, many species of groundfish, such as lingcod and rockfish, use submerged aquatic vegetation for feeding, refuge from predators, and nursery (Mumford 2007).

Surveys conducted by Whatcom County (Fairbanks 2005) indicate that the submerged aquatic vegetation between the BP and Alcoa piers is dominated by large patches of low-density (1 percent to 50 percent plant cover) *Sargassum*, with smaller patches of low-density bull kelp, and isolated patches of low- and high-density eelgrass. Bull kelp potentially provides refuge habitat for a number of groundfish species, especially rockfish. The largest patch of bull kelp identified during the surveys conducted by Whatcom County lies north of the BP pier at Point Whitehorn (Fairbanks 2005). A small patch of bull kelp lies south of the proposed Terminal.

### **5.3.1.3 Federally Listed Threatened and Endangered Species**

The Endangered Species Act (ESA) was established in 1973 to protect endangered species and their habitats. The ESA authorizes the NOAA Fisheries Service and USFWS to identify species that need to be protected, or listed, under the ESA. Species listed by the NOAA Fisheries Service and USFWS that occur in the vicinity of the Strait of Georgia are listed in Tables 5-6 and 5.7, respectively.

**Table 5-6 Federally Listed Species that Could Occur Near the Strait of Georgia Identified by NOAA Fisheries Service**

Name	Scientific Name	Evolutionarily Significant Unit (ESU)	Federal Status
Chinook salmon	<i>Oncorhynchus tshawytscha</i>	Puget Sound	Threatened
Steelhead trout	<i>Oncorhynchus mykiss</i>	Puget Sound	Threatened
Humpback whale	<i>Megaptera novaeangliae</i>	North Pacific Ocean	Endangered
Killer whale	<i>Orcinus orca</i>	Southern Resident Population	Endangered
Steller sea lion	<i>Eumetopias jubatus</i>	Eastern Distinct Population Segment	Threatened
Leatherback sea turtle	<i>Dermochelys coriacea</i>	Pacific Ocean	Endangered
Bocaccio	<i>Sebastes paucispinis</i>	Georgia Basin	Endangered
Canary rockfish	<i>Sebastes pinniger</i>	Georgia Basin	Threatened
Yelloweye rockfish	<i>Sebastes ruberrimus</i>	Georgia Basin	Threatened

**Table 5-7 Federally Listed Species that Could Occur Near the Strait of Georgia Identified by the USFWS**

Name	Scientific Name	Population Segment	Federal Status
Bull trout	<i>Salvelinus confluentus</i>	Coastal/Puget Sound	Threatened
Marbled murrelet	<i>Brachyramphus marmoratus</i>	California/Oregon/Washington	Threatened

NOAA Fisheries has also identified coho salmon (*Oncorhynchus kisutch*), Puget Sound/Strait of Georgia distinct population segment (DPS) as a species of concern, but coho are not protected under the ESA at this time. A more detailed biological description of each of the species will be in the *Biological Evaluation* for the proposed Gateway Pacific Terminal, which is currently under development.

#### 5.3.1.4 State Priority Habitats and Species

WDFW defines *priority species* as those that require protective measures for their survival due to their population status, sensitivity to habitat alteration, or recreational, commercial, or tribal importance. *Priority habitats* are those areas with unique habitat features, or habitat features of significance to a diverse assemblage of species. Marine species identified as State Priority Species that occur along the Whatcom County shoreline area are summarized in Table 5-8. Priority habitat includes the nearshore area (classified by WDFW as Puget Sound Nearshore).

This section provides a brief description of the State Priority Species that may use the marine nearshore in the vicinity of the proposed Terminal. A more detailed analysis of the proposed Terminal on threatened and endangered and priority species will be provided in the forthcoming Biological Evaluation.

**Table 5-8 Marine State Priority Species that Could Occur at the Gateway Pacific Terminal Site**

	<b>Common Name</b>	<b>Scientific Name</b>	<b>State Status</b>	<b>Federal Status</b>
<b>Forage Fish</b>	Pacific herring	<i>Clupea pallasii</i>	Species of Concern	
	Surfsmelt	<i>Hypomesus pretiosus</i>	None	
	Pacific sand lance	<i>Ammodytes hexapterus</i>	None	
<b>Salmon and Trout</b>	Bull trout/Dolly Varden	<i>Salvelinus confluentus</i>	Candidate	Threatened
	Chinook Salmon	<i>Oncorhynchus tshawytscha</i>	Candidate	Threatened
	Chum salmon	<i>Oncorhynchus keta</i>	Candidate	Threatened
	Coastal Resident/Sea-run cutthroat	<i>Oncorhynchus clarki clarki</i>	None	
	Coho	<i>Oncorhynchus kisutch</i>	Candidate	Species of Concern
	Kokanee	<i>Oncorhynchus nerka</i>	None	
	Pink salmon	<i>Oncorhynchus gorbuscha</i>	None	
	Rainbow trout/steelhead	<i>Oncorhynchus mykiss</i>	Candidate	Threatened
	Sockeye salmon	<i>Oncorhynchus nerka</i>	Candidate	
<b>Groundfish</b>	Pacific cod	<i>Gadus macrocephalus</i>	Candidate	Species of concern
	Pacific hake	<i>Merluccius productus</i>	Candidate	Species of concern
	Walleye pollock	<i>Theragra chalcogramma</i>	Candidate	Species of concern
	Black rockfish	<i>Sebastes melanops</i>	Candidate	
	Bocaccio rockfish	<i>Sebastes paucispinis</i>	Candidate	Endangered
	Brown rockfish	<i>Sebastes auriculatus</i>	Candidate	Species of concern
	Canary rockfish	<i>Sebastes pinniger</i>	Candidate	Threatened
	Copper rockfish	<i>Sebastes caurinus</i>	Candidate	Species of concern
	Greenstriped rockfish	<i>Sebastes elongatus</i>	Candidate	
	Quillback rockfish	<i>Sebastes maliger</i>	Candidate	Species of concern
	Redstripe rockfish	<i>Sebastes prioriger</i>	Candidate	
	Yelloweye rockfish	<i>Sebastes reuberrimus</i>	Candidate	Threatened
	Yellowtail rockfish	<i>Sebastes flavidus</i>	Candidate	
	Lingcod	<i>Ophiodon elongatus</i>	None	
	English sole	<i>Parophrys vetulus</i>	None	
	Rock sole	<i>Lepidopsetta bilineata</i>	None	
Longfin smelt	<i>Hypomesus pretiosus</i>	None		
<b>Invertebrates</b>	Pinto abalone	<i>Haliotis kamtschatkana</i>	Candidate	Species of Concern
	Butter clam	<i>Saxidomus giganteus</i>	None	
	Native littleneck clam	<i>Protothaca abrupta</i>	None	
	Dungeness crab	<i>Cancer magister</i>	None	
	Pandalid shrimp	<i>Pandalus</i> spp.	None	
	Red urchin	<i>Strongylocentrotus franciscanus</i>	None	
<b>Marine Mammals</b>	Dall's porpoise	<i>Phocoenoides dalli</i>	None	
	Gray whale	<i>Eschrichtius robustus</i>	Sensitive	
	Harbor seal	<i>Phoca vitulina</i>	None	
	Orca (Southern Resident Killer Whale)	<i>Orcinus orca</i>	Endangered	Endangered
	Pacific harbor porpoise	<i>Phocoena phocoena</i>	Candidate	

Source: WDFW 2010

## Forage Fish

Forage fish are important prey fish for a variety of larger marine fish and marine mammals. Forage fish are known to spawn on intertidal beaches at Cherry Point; however, only herring are known to spawn near the project area, so only herring are described in detail herein.

### *Herring*

Pacific herring live in coastal waters, ranging along the Pacific Coast of North America from northern Baja California north to the Beaufort Sea, and in the Russian Arctic from the Chuckchi Sea in the east to the White Sea in the west. A large number of herring stocks, or metapopulations, and numerous occurrences of other more diverse, localized populations occur throughout the range of Pacific herring (Gustafson et al. 2006).

Pacific herring at Cherry Point (Cherry Point herring) spawn from April to mid-June, with peak spawning activity during the first or second weeks of May. WDFW studies have shown that herring form a pre-spawning aggregation (Trumble et al. 1982) offshore, where ripening adult herring congregate and hold for 3 to 4 weeks prior to moving toward the spawning grounds on the inter- and subtidal areas of the beach to spawn. The presumed location of the pre-spawn holding area for Cherry Point herring is shown in Figure 5-6, which is based on WDFW publications regarding reports from fishermen (Stick and Lindquist 2009; O'Toole 2010). Egg deposition typically occurs between +3.0 feet MLLW to the lower limits of algal growth at around -20 feet MLLW, with most spawning occurring between 0 and 10 feet MLLW. Herring spawn on eelgrass and macroalgae species, including *Laminaria* sp. and *Sargassum muticum* (WDFW, unpublished data, 2008). Following spawning, eggs incubate for 10 to 14 days prior to emergence, after which time larvae drift in nearshore currents for 2 to 3 months before becoming juveniles.

Cherry Point herring have shown a large decline in abundance since 1973. As a result, a number of studies have been conducted to identify the cause of their decline. The first major study conducted to evaluate the cause of the decline in the Cherry Point herring stock was a Regional Risk Assessment (EVS 1999). Since then, two petitions have been filed to protect the population under the ESA. The petitions led NOAA Fisheries to appoint a Biological Review Team to conduct a status review of the species in 2001 (Stout et al. 2001) and again in 2006 (Gustafson et al. 2006).

Both the Regional Risk Assessment and status reviews identified and evaluated potential factors for the decrease in abundance of the Cherry Point herring stock. It is generally agreed that the decline was probably initiated by a periodic, recurring shift in climate that occurred in 1977 (known as the Pacific decadal oscillation), which coincides with the beginning of the population decline (Chavez et al. 2003). Other factors that may have contributed to the decline in Cherry Point herring include physical stressors, such as temperature and salinity; biological stressors, such as lack of suitable food

supply, competition, larval abnormalities, reduction in size at maturity, parasites, disease, and predation; and anthropogenic stressors, including fisheries harvest, habitat modification, vessel traffic, noise, contaminants, and ship ballast (Gustafson et al. 2006). The 1999 *Cherry Point Screening Level Ecological Risk Assessment* (EVS 1999) determined that the current downward trend in the Cherry Point herring stock may be caused primarily by increased mortality of adults. Similarly, the 2001 status review of Pacific herring concluded that the decline in Georgia Basin herring was due to reduced recruitment of 3-year-old herring, and losses of older fish (Stout et al. 2001). In 2004, most of the spawning population consisted of fish 3 to 5 years old, and there has been an apparent temporal decline in size-at-age of Cherry Point herring since 1973 (Gustafson et al. 2006).

Predation is another potential explanation for the decline in Cherry Point herring. Pacific herring provide food for a multitude of species, including birds, fish, marine mammals, and benthic invertebrates. Bird predation is speculated to be the greatest source of egg loss, potentially resulting in egg mortality of 30 to 90 percent per spawning year (Taylor 1955). Seabirds have also been documented to graze heavily on intertidal plants covered with Pacific herring eggs, which may have contributed to the patchiness and zonation of eelgrass and macroalgae (Bayer 1980). Several species of fish are known to prey on Cherry Point herring, with Pacific hake the most significant predator in open waters off the coast of Vancouver Island (EVS 1999). Similarly, Pacific herring make up 32 percent of the diet of harbor seals (Environment Canada 1998), the most abundant pinniped in Washington (Jeffries et al. 1996). Recent studies show that herring pre-spawn holding areas appear to be important foraging habitat for harbor seals (Thomas et al. 2009). Benthic marine invertebrates also prey on Pacific herring eggs, with egg loss due to predation by invertebrates estimated at 8 percent in British Columbia (Haegele 1993). Combined, predation by birds, fish, marine mammals, and benthic invertebrates places substantial pressure on the Cherry Point herring stock.

Food availability was evaluated as a cause of the decline (EVS 1999). Herring feed selectively on plankton during all life-history stages. Larval herring feed on copepods, invertebrate eggs, and diatoms. Juvenile herring feed on larger copepods and other invertebrates common in eelgrass beds, such as barnacle larvae and chaetognaths (Levings 1983). Adults feed on invertebrates, such as copepods, and small fishes. One of the principal food sources for Pacific herring is a large and nutritious calanoid copepod (*Neocalanus plumchrus*). It is documented that zooplankton biomass in the upper layer of the Strait of Georgia peaks in April through early June, and is dominated by *N. plumchrus*. Studies show that *N. plumchrus* went into a steep decline in the early 1970s, while populations of other, smaller copepod species increased (Gardner 1977). However, EVS (1999) determined that no overall correlation exists between food availability (chlorophyll *a* and invertebrate biomass) and recruitment to the Cherry Point herring stock. Therefore, food availability is not considered a current risk factor for Pacific herring populations.



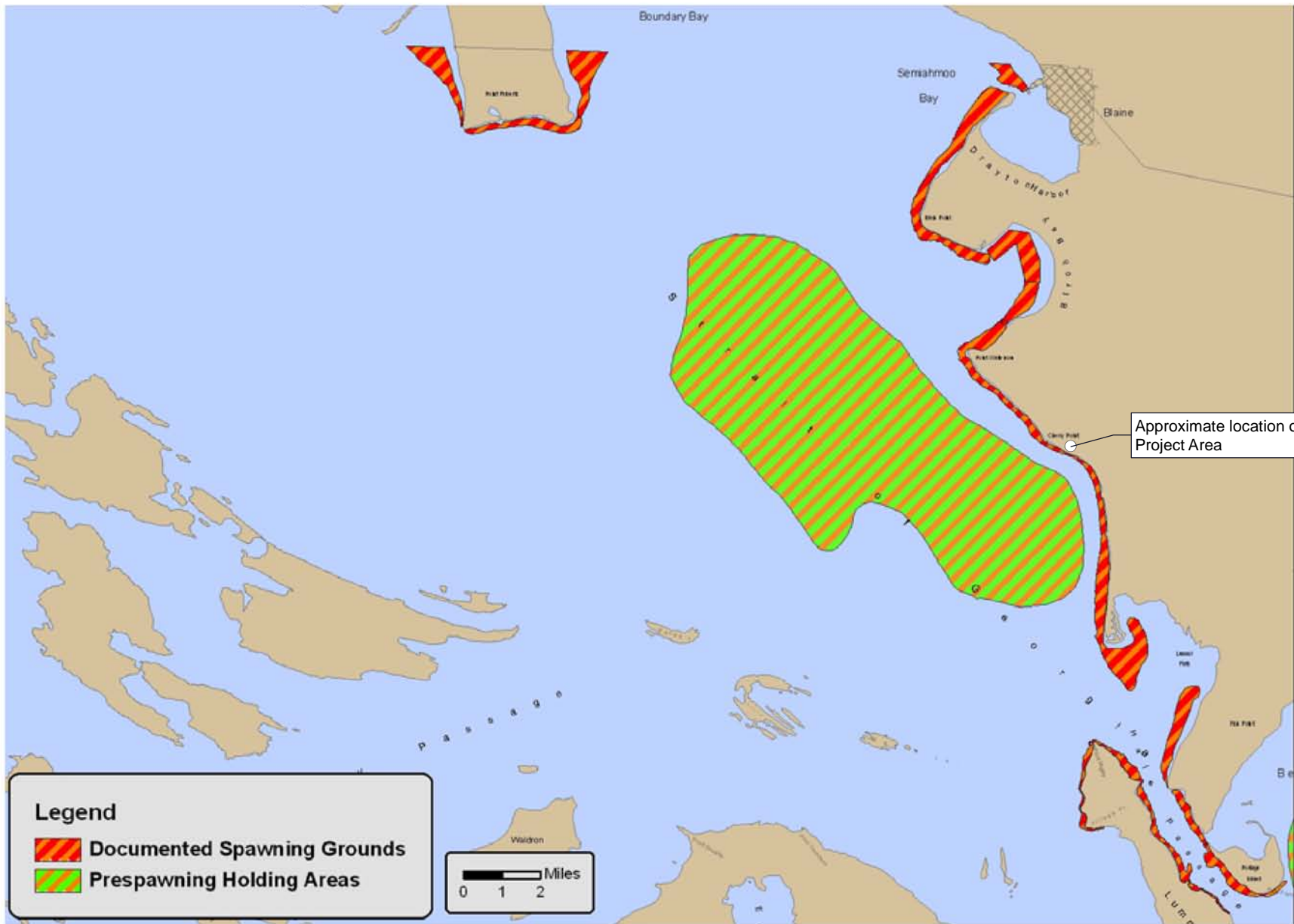

SOURCE: Figure 2: Documented herring spawning grounds and presumed pre-spawning holding areas, *Cherry Point Herring Effects Analysis*, Washington Department of Fish and Wildlife, 2009.



CLIENT:

PACIFIC INTERNATIONAL TERMINALS, INC.

DWN BY:

SD

CHKD BY:

KD

DATUM:

-

PROJECTION:

-

SCALE:

AS SHOWN

PROJECT:

PROPOSED GATEWAY PACIFIC TERMINAL

TITLE:

CHERRY POINT HERRING SPAWN AREA

DATE:

FEBRUARY 2011

PROJECT NO.:

091515338C-18-01

REV. NO.:

-

FIGURE NO.:

5-6



Seasonal changes in temperature are important for regulating the timing of spawning migration and metabolic development rates of Pacific herring (Gustafson et al. 2006). In addition, the 1999 Risk Assessment (EVS 1999) mentioned a relationship between temperature and increased predation on Cherry Point herring.

Habitat modification is another potential factor for the decline in Cherry Point herring. Herring spawn on intertidal vegetation, including eelgrass. While the decline of habitat, particularly eelgrass, at Cherry Point has been hypothesized as a factor for the decline in Cherry Point herring, the distribution and quantity of spawning substrate is subject to natural conditions, and thus varies yearly due to storms, natural littoral processes, and growth of eelgrass and macroalgae beds (Kyte 1999, 2000, 2001, 2002, 2003, 2004).

The existing marine structures at Cherry Point result in some shading of intertidal habitat, potentially resulting in some disruption of the spatial distribution of macroalgae. However, the degree of the impact depends on the vegetation type and the type of overwater structures. Field observations under overwater structures near Cherry Point show the potential for macroalgae to flourish if hard substrate is available (Shapiro & Associates 1996). Other studies have shown that overwater structures result in some reduction in macroalgae and eelgrass growth (Gustafson et al. 2006).

Whereas shading associated with overwater structures at Cherry Point may have resulted in some reduction in macroalgae and eelgrass, and thus some reduction in spawning area, experts agree that spawning substrate is not a limiting factor for Cherry Point herring (EVS 1999).

### **Groundfish and Schooling Fish**

A number of groundfish listed as State Priority Species are likely to occur near the Terminal during the juvenile phase of their lives. They are most likely to occur near submerged aquatic vegetation for feeding, refuge from predators, and nursery (Mumford 2007). Bull kelp near the proposed Terminal potentially provides refuge habitat for a number of groundfish species, especially rockfish. A small patch that may provide habitat to groundfish species lies to the south of the proposed Terminal. The common habitat type and typical depth interval for State Priority List groundfish species that may occur in the vicinity are provided in Table 5-9.

### **Marine Invertebrates**

Representative invertebrate species that may be present at the Terminal site include Dungeness crabs, red urchins, butter clams, native littleneck clams, and pandalid shrimp. Pinto abalone is a priority species and has not been documented to occur at the site.

Dungeness crab spawn in the spring and larvae from the Puget Sound region may disperse as far as Alaska (Park et al. 2007). This species is a carnivore that feeds on more than 40 different species, including small clams, oysters, fish, shrimp, and worms.

Red sea urchins are found in the intertidal to subtidal zone on seaweed, surfgrass, eelgrass, and rocks. There is a small commercial fishery for this species in the San Juan Islands, but not in the vicinity of the project site.

Adult and juvenile native littleneck clams are found in coarse, sandy-rock muds of the upper intertidal beaches of estuaries and on the open coast where appropriate substrate, detritus (decaying plant material), and protection from predators are present. Native littlenecks stay buried at a depth of around 80 mm due to their relatively short siphons (WSU 2007, Kegel 1998). Their siphons allow this species to gather food by filtering water for phytoplankton and diatoms. Rock crabs, fish, birds, and other predators feed on these clams depending on the region. Native littlenecks spend 2 to 3 weeks in the larval form (Shaw 1986).

Spot prawns, a species of Pandalid shrimp, inhabit the deep sandy bottoms in the Rosario Strait area. They feed on crustaceans, polychaetes, limpets, and carcasses. The breeding season for spot prawns ends in late October, after which females carry their eggs on the abdomen for 4 to 5 months while remaining in deep water. The eggs hatch in March or April, with the larvae settling a few months later in May and June. Juveniles feed in shallow water during summer, especially among *Agarum fimbriatum* and *A. clathratum* kelp. During their second fall (carapace length 2.8 cm), they become males, which they remain until they grow to 3.3 cm carapace length, at which time they become females. Females may mate only once, and they may not live longer than 4 years (O'Clair and O'Clair 1998)

### **Marine Mammals**

Marine mammals included on the WDFW State Priority Species List that could occur in the nearshore waters at the Terminal site include Dall's porpoises, gray whales, harbor seals, Southern Resident killer whales (also protected under the ESA as described previously), and the Pacific harbor porpoise. A more detailed analysis of the proposed Terminal on threatened and endangered and priority species will be provided in the forthcoming Biological Evaluation.

**Table 5-9 Groundfish on the State Priority List that Could Occur near the Gateway Pacific Terminal Site**

<b>Species</b>	<b>Habitat Type</b>	<b>Common depth range</b>
Pacific cod	Schooling species over soft or gravel substrate	150-900 feet
Pacific hake	Dense, mid-water schools	150-600 feet
Walleye pollock	Schooling, mid-water to bottom-dwelling fish	300-900 feet
Black rockfish	Relatively mobile, mid-water dwelling fish found in kelp beds and shallow reefs	40-300 feet
Bocaccio rockfish	Adults in rocky areas, juveniles under dense kelp mats	150-1,000 feet
Brown rockfish	Bottom dwellers living on hard bottom or sand, near structures (piers, oil platforms, etc.)	20-440 feet
Canary rockfish	Found near the bottom, usually near pinnacles and sharp drop-offs.	150-750 feet
Copper rockfish	Near the bottom, over sand, near rock-sand interfaces. Not highly mobile.	20-60 feet
Greenstriped rockfish	Solitary, found on mud, cobble or mud-rock interface	150-800 feet
Quillback rockfish	On or near the bottom, living among rocks or on coarse sand or pebbles next to reefs in areas with flat-bladed kelp.	40-250 feet
Redstripe rockfish	Generally schooling, but sometimes isolated	70-150 feet
Yelloweye rockfish	Solitary, occurring on or over rocky reefs	150-1,200 feet
Yellowtail rockfish	Mid-water schooling fish found over rocky and hard bottoms, and occasionally over sand and mud.	300-450 feet
Lingcod	Bottom dwelling, solitary in a variety of habitats including sand, gravel, and eelgrass beds.	0-200 feet
English sole	Soft bottom	150-900 feet
Rock sole	Pebbly or semi-rocky bottom	0-300 feet
Longfin smelt	Anadromous species	0-300 feet

Source: Love 1996

## 5.3.2 Effects of Construction on Marine Resources

### 5.3.2.1 Fisheries

An effects analysis is currently under development and will be provided as a future supplement to this document.

### 5.3.2.2 Marine Physical Processes and Bathymetry

Marine physical processes could potentially be affected by the presence of the marine trestle and wharf structure, and is discussed in Section 5.3.3.1.

The Cherry Point shoreline's unique bathymetric contours provide deepwater access without the need to dredge berthing areas. Therefore, there would be no effect to the bathymetry due to construction of the proposed wharf and trestle.

### **5.3.2.3 Marine Biological Communities**

The footprint of the proposed marine wharf and trestle would be supported by steel piles. Construction and installation of the steel piles supporting the marine trestle would result in a loss of 333 square feet of nearshore habitat, potentially displacing marine invertebrates. Similarly, the piles supporting the marine wharf would displace 9,169 square feet of subtidal habitat.

#### **The Backshore**

Construction activity would result in the temporary displacement of animals using the marine riparian vegetation in the backshore, as described in Section 5.2.

#### **The Intertidal Community and Shallow Subtidal**

Trestle construction in the intertidal and shallow subtidal portions of the beach would not noticeably affect invertebrate populations, except for benthic invertebrates found at the immediate piling locations that would be destroyed during pile installation. Construction of the marine trestle would displace a total of 333 square feet of shallow subtidal habitat for marine invertebrates.

#### **The Subtidal Community**

Construction effects on the subtidal community would include displacement of benthic habitat. The wharf would be supported by 730 steel piles with a diameter of 48 inches. The piles would be configured such that 298 piles would form the perimeter and 432 piles would form the interior under the wharf. These piles would displace an area of 9,169 square feet (0.2 acre) of benthic habitat.

Dungeness crab could be temporarily affected by the potential increase in turbidity associated with pile driving. An increase in turbidity could contaminate gill structures; however, it is more likely that juvenile and adult Dungeness crabs would avoid the immediate areas of construction.

### **5.3.2.4 Federally Listed Threatened and Endangered Species**

The effects of the proposed project on ESA-listed species are currently under evaluation. A more detailed analysis of the proposed Terminal on threatened and endangered and priority species will be provided in the forthcoming Biological Evaluation.

### **5.3.2.5 State Priority Habitats and Species**

This section describes potential effects of project construction on state priority habitats and species.

#### **Forage Fish**

Construction-related noise associated with the proposed project is not likely to affect forage fish adversely. Surfsmelt and sand lance may occur within the proposed project area, but they do not

spawn in the vicinity of the project area, so they are not likely to be affected adversely by the proposed project.

Cherry Point herring are known to spawn in the project vicinity. The primary construction-related factors that may affect Cherry Point herring are potential shading, which could cause a decrease in spawning habitat and primary productivity, and noise and vessel traffic, which could interfere with herring spawn migration.

A more detailed analysis of the effects of the proposed project on Cherry Point herring will be included as an appendix to the Biological Evaluation.

### **Groundfish**

Groundfish are highly mobile and would likely avoid the area during construction.

### **Marine Invertebrates**

Pile driving and construction activities would result in both temporary and permanent displacement of marine invertebrates. Benthic invertebrates in the footprint of the proposed support piles would be permanently displaced.

## **5.3.3 Effects of Operation on Marine Resources**

This section describes potential effects of operation of the Terminal on marine resources. A more detailed analysis of the proposed Terminal on threatened and endangered and priority species will be provided in the forthcoming Biological Evaluation.

### **5.3.3.1 Marine Physical Processes and Bathymetry**

The presence of the marine trestle and wharf in the nearshore could potentially reduce wave energy on the sheltered side of the structure, ultimately influencing sediment transport behavior. Westmar evaluated energy reduction associated with the waves, as the waves propagate past rows of piles (Westmar 1996). Reflection and transmission of waves through the piles of the wharf and trestle were calculated to determine the effect of the waves passing through the rows of piles to the shoreline (Westmar 1996).

The study showed that waves from the south and southwest sectors would be reduced in height by approximately 1 percent, as measured at the contact with the shoreline. Waves from the west and northwest would be reduced by less than 0.1 percent as measured at contact with the shoreline (Westmar 1996). For waves propagated parallel to the rows of piles (pile bents), relatively little reduction in wave height occurred in association with wave propagation past the piles, since the 30-foot span between pile bents is sufficiently wide to not have much influence on wave height.

However, when waves approach the wharf head more obliquely, they may need to propagate through several pile bents, creating greater potential for reduced wave height, and a corresponding reduction of wave energy.

The transmission coefficient for waves approaching from the south, southwest, west, and northwest was calculated using wave height, wave period, wave direction, pile diameter, pile spacing within each row, the length of each row, and the spacing between each row. The results indicate that waves from the south and southwest are minimally attenuated by the piles, waves from the west undergo a slight reduction, and waves from the northwest would be reduced even more, since the waves would need to propagate past many rows of piles (Westmar 1996).

The reduction in wave energy on the sheltered side of the wharf head is not expected to affect sediment deposition. Waves from the west would give rise to the greatest reduction in wave energy on the sheltered side of the wharf head. Taking into account the wave diffraction around the ends of the wharf head, wave heights at the shore would be somewhat reduced, resulting in some sediment accretion. However, this sediment accretion is not expected to be significant, particularly as waves from the south would tend to disturb any accumulated sediments (Westmar 1996).

Based on site conditions, including wave action, currents, sediment, and beach characteristics, the proposed facility should have no significant effect on physical habitat conditions at the Terminal. There would be no effect on bathymetry at the site.

#### **5.3.3.2 Marine Biological Communities**

If the shading from the proposed trestle is not mitigated, it could potentially result in a net decrease in primary productivity due to decreased macroalgae biomass. A more detailed analysis of the proposed Terminal on threatened and endangered and priority species will be provided in the forthcoming Biological Evaluation.

#### **The Backshore**

The long term effects of the facility on the backshore would be negligible, as the height of the trestle as it passes over the backshore would not likely interfere with vegetation growing in the marine riparian community. The proposed wetland mitigation would result in a net increase in coastal lagoon habitat south of the proposed Terminal.

#### **The Intertidal and Shallow Subtidal Community**

Effects on the intertidal and shallow subtidal communities are evaluated jointly because both communities are located within the photic zone, and thus operation of the proposed Terminal would



have similar effects due to shading and habitat displacement associated with the footprint of support piles.

A shading study was conducted in 1992 and 1993 to evaluate the effects of the proposed project on marine vegetation in the intertidal and shallow subtidal communities (Shapiro & Associates 1996). The study was used to generate a model to predict the reductions in incident light levels that might be expected under the proposed trestle. The model predicted that on a sunny day during the growing season, conditions under the centerline from the proposed trestle would still provide more total incident light for photosynthesis (ranging from 20 percent to 41 percent more), than the total incident light available away from the trestle on cloudy days. Furthermore, field observations of overwater structures near Cherry Point show the existence of macroalgae growing if there is hard substrate available (Shapiro & Associates 1996). Therefore, it was predicted that there would be minimal loss of biomass of the vegetative community under the proposed wharf and trestle.

As described previously, some benthic habitat would be lost during construction; however, offshore piles provide an attachment substrate for marine invertebrates. It is assumed that, upon completion of the intertidal and shallow subtidal portions of the trestle and wharf, submerged surfaces of the piles would be colonized by a succession of barnacles, mussels, and other encrusting marine invertebrates. Assuming that an average length of 20 feet of piling surface on each of the proposed support piles would support attachment of marine organisms, an area of 22,608 square feet of potential habitat for marine organisms would result from the trestle, resulting in a net gain of 0.5 acre of invertebrate habitat. Although the species community would be different from the species affected, the result would be a net increase in invertebrate biomass.

### **Subtidal**

Effects on the subtidal community during Terminal operations would include vessel traffic and the creation of invertebrate attachment habitat and habitat for reef-dwelling fish.

If it is again assumed that an average length of 20 feet on the perimeter and average length of 5 feet on each interior pile would support attachment of marine invertebrates, a total area of 2.8 acres of potential habitat for marine invertebrates would be created by the project, resulting in an overall net gain of 2.6 acres of invertebrate habitat. Ultimately, benthic invertebrates in the footprint of the proposed piles would be eliminated; however, the surface of the piles would provide habitat for encrusting marine invertebrates.

Finally, whereas Dungeness crabs could be temporarily displaced during construction, the proposed structure would provide shelter for the crabs, and would potentially result in a net increase in Dungeness crab production (Nightingale and Simenstad 2001).

### **5.3.3.3 Federally Listed Threatened and Endangered Species**

A more detailed analysis of the proposed Terminal on threatened and endangered and priority species will be provided in the forthcoming Biological Evaluation.

### **5.3.3.4 State Priority Habitats and Species**

This section describes potential operational effects on State Priority Habitats and Species.

#### **Forage Fish**

While surfsmelt and sand lance may occur within the proposed project area, they do not spawn in the vicinity of the proposed project, so they are not likely to be affected by the proposed project adversely.

Operational noise could potentially affect Cherry Point herring. Herring respond to a variety of auditory inputs, including marine mammal echolocation sounds (Wilson and Dill 2002) and apparent production of endogenous sounds (Wilson et al. 2003). Assuming that Pacific herring have a noise threshold of 75 dB and vessels generally emit noise levels of 145 dB in the same frequency range, Pacific herring would be able to detect the vessels. However, it is unknown whether the noise would be significant enough for herring to react to the disturbance. The Cherry Point stock has continuously spawned near the BP Cherry Point refinery pier, despite elevated frequency of vessel traffic and increases in the associated noise (EVS 1999). Although it is anticipated that Cherry Point herring would be able to detect noise associated with vessel traffic, the disturbance is not anticipated to affect Cherry Point herring adversely.

Herring that spawn at Cherry Point hold temporarily in an offshore area prior to moving inshore to spawning habitat. When the Cherry Point herring fishery was active (1988 to 1996), WDFW staff observed that herring fishing activity was typically concentrated near a bathymetric trench located along the southern boundary of the proposed Gateway Pacific Terminal site, suggesting that the highest concentrations of herring may occur at the location of the proposed Gateway Pacific Terminal (Settlement Agreement 1999). The specific area identified by WDFW is the area offshore from Cherry Point proper and extending south to the mouth of the seasonal creek on the property owned by Pacific International Terminals (O'Toole 2010). This area encompasses the northwestern "wing" of the proposed wharf structure included as part of the proposed Gateway Pacific Terminal.

According to Mark O'Toole (2008), WDFW identified the preferred holding area for Cherry Point herring by monitoring fishing activity in the harvest area for herring spawn-on-kelp (kelp with a covering of herring eggs). The Cherry Point spawn-on-kelp fishery started in 1988 and closed in 1996 (due to low spawning stock size). Starting with the first year of the fishery, it became clear that this area contained an unusually large number of herring schools. WDFW staff noticed that at least 50 percent of the seine sets and approximately 60–70 percent of the successful catches (O'Toole

2008) occurred in this relatively small area (the area just north of Gulf Road up to Cherry Point proper).

To evaluate WDFW's conclusion that the preferred holding area for pre-spawning herring is within the footprint of the proposed project, Pacific International Terminals obtained hydroacoustic surveys of herring distribution in the Cherry Point area to determine whether preferred nearshore migration corridors/schooling areas truly exist at or near the Gateway Pacific Terminal site. In 1998 and 2004, relative school size and location were examined to determine whether the relative spatial and temporal distribution of herring spawning concentrations suggested potential migration pathways. Results of the surveys indicate that herring do not show any particular spatial pattern when spawning (Resource Analysts International 2006). In both years, herring were found distributed throughout the survey area, with no evidence that herring favor one area over another for entering or leaving the nearshore spawning grounds (Resource Analysts International 2006). The results of these hydroacoustic studies are corroborated by data from tagging studies conducted by Pacific International Terminals (Hay et al. 2001) that indicate Cherry Point herring do not follow specific migration patterns.

Although hydroacoustic data do not support the conclusion that the presumed Cherry Point herring holding area lies within the footprint of the proposed wharf and trestle, vessel traffic for the proposed Gateway Pacific Terminal would likely cross through the holding area. WDFW has expressed concern over the potential for propeller wash associated with vessel traffic, decreased light penetration due to vessel traffic, and general disturbance to herring associated with vessel activity.

Propeller wash associated with vessel traffic could potentially affect Cherry Point herring using the presumed holding area. Data show that Pacific herring hold near the bottom of the water column in depths ranging from 69 to 121 feet below the surface (EVS 1999). Because the largest inbound vessels proposed to use the Gateway Pacific Terminal draw no more than 65 feet and would likely be powered by tug, not by the ship itself, it is presumed that they would have no direct effect on Pacific herring.

There has also been concern that the physical presence of the marine facility and noise from ship movements and unloading operations would somehow disrupt herring spawning migration to the extent it could be a significant impact to survival of the stock. There is no evidence that herring are sensitive to ship noise at Cherry Point. The Cherry Point herring stock has returned year after year to the Point Whitehorn-Sandy Point area despite ongoing operation of the three industrial piers in the vicinity (EVS 1999). A recent analysis of herring spawning frequency relative to vessel traffic at Cherry Point showed that herring spawn at Cherry Point whether vessels are present or not, with some tendency toward increased spawning frequency when vessels are present (O'Toole 2010).

In other industrial areas, including San Francisco Bay and Fidalgo Bay, herring have been documented to spawn on dock pilings and the bottoms of ships. Ken Ota, lead herring biologist at the California Department of Fish and Game, provided information on the interaction between vessel traffic and herring spawning behavior in San Francisco Bay (Ota 2006). Mr. Ota indicated that herring generally display initial avoidance to ship traffic, but the avoidance behavior is temporary, and does not appear to affect spawning. Herring spawning has been occurring in the presence of vessel traffic in San Francisco Bay for more than a century. In San Francisco Bay, herring spawn along the edge of the shipping channels, indicating that vessel traffic does not interfere with herring spawning in San Francisco Bay. Similarly, observations show that vessel traffic at the BP and Intalco docks at Cherry Point, in San Francisco Bay, and in Fidalgo Bay have not affected herring spawning behavior (O'Toole 2010).

### **Marine Invertebrates**

The proposed marine wharf and trestle would provide habitat for marine invertebrates. Pier piles would be colonized by marine invertebrates, such as mussels and barnacles, potentially resulting in a net increase in biota. The proposed structure would provide shelter for the crabs, and would potentially result in a net increase in Dungeness crab production (Nightingale and Simenstad 2001).

### **5.3.4 Proposed Design Features Intended to Reduce Impacts**

Features intended to reduce impacts to Marine Resources include mitigation that would result in response to ongoing investigations, mitigation associated with impacts to wetlands, voluntary mitigation (removal of an abandoned creosote-pile conveyor), mitigation agreed to under the Settlement Agreement (1999), and implementation of best management practices (BMPs), as detailed below. Specific measures would include an enhanced macroalgae mitigation area (Figure 5-7) and removal of an existing overwater structure (Figure 5-8).

#### **5.3.4.1 Fisheries**

Construction would be timed to avoid impacts to commercial, Tribal, and recreational fisheries. The applicant will begin coordination immediately with WDFW and the Tribes to identify potential impacts to fisheries and possible strategies to reduce impacts.

#### **5.3.4.2 Marine Physical Processes and Bathymetry**

Based on studies conducted by Westmar in 1996, the effects of the proposed project on marine physical processes would be negligible. Additional data are currently being collected to finalize the design and to minimize the effects on marine physical processes.

The proposed project would have no effect on bathymetry. The location of the facility in naturally occurring deep water eliminates the need for dredging.

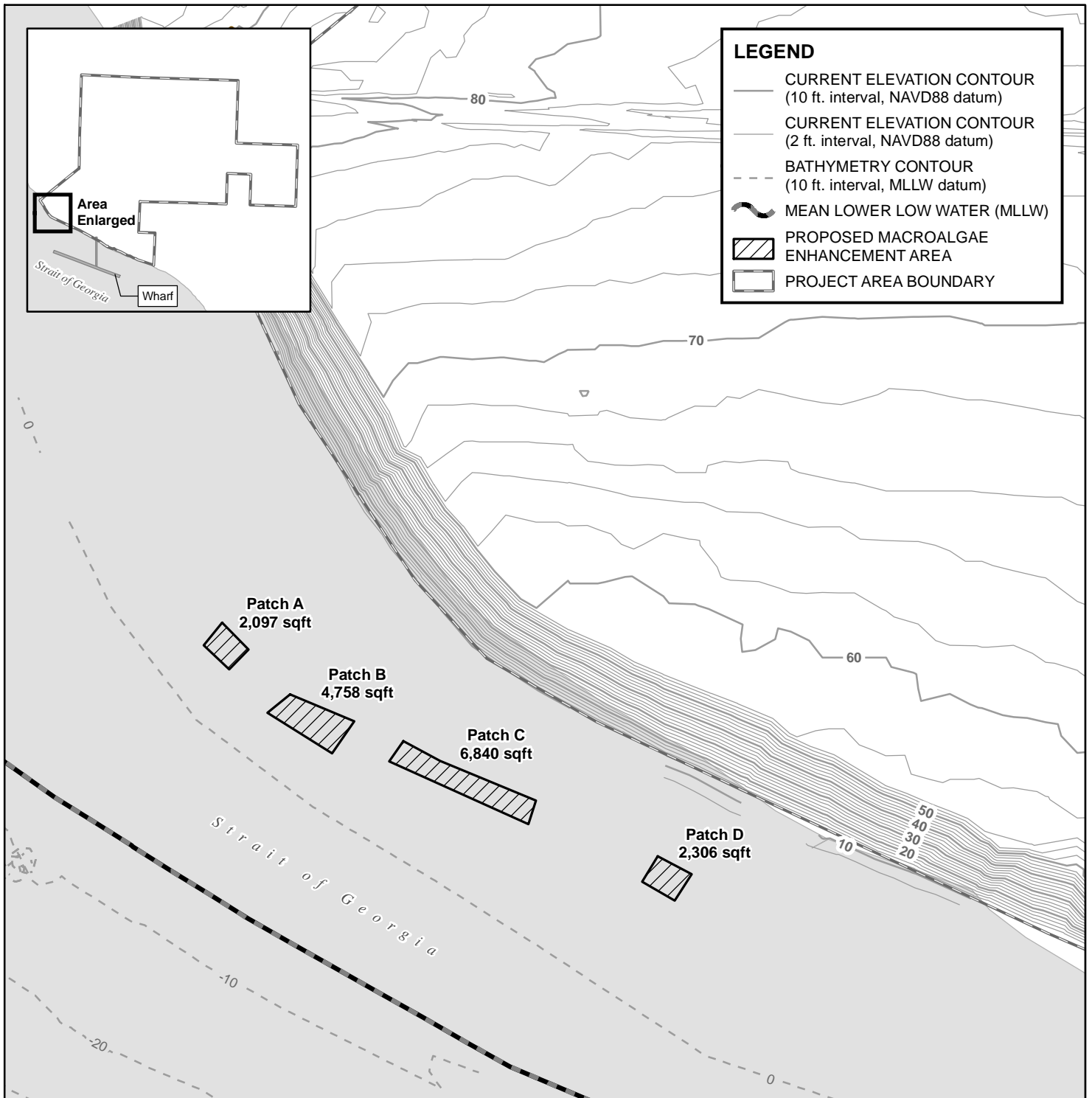

Source:  
 Ausenco Sandwell, 154199-A100-42S01.dwg (Rev. J), 12/24/2010.  
 David Evans & Associates, 2010-04-14-svTPXpit0006-DEGROSS.dwg,  
 07/20/2010.

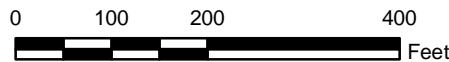



				CLIENT: <b>PACIFIC INTERNATIONAL          TERMINALS, INC.</b>	
PROJECT: <b>PROPOSED GATEWAY PACIFIC TERMINAL</b>		DWN BY: SD	DATUM: NAD83	DATE: FEBRUARY 2011	
TITLE: <b>MACROALGAE ENHANCEMENT AREA</b>		CHK'D BY: KD	REV. NO.: 1	PROJECT NO.: 091515338C-18-01	
		PROJECTION: WA SP North, Ft.	SCALE: 1 inch=200 feet	FIGURE No.: <b>FIGURE 5-7</b>	







**LEGEND**

-  MEAN HIGHER HIGH WATER (MHHW)
-  BATHYMETRY CONTOUR  
(20 ft. interval, MLLW datum)
-  ABANDONED BELT CONVEYOR  
(0.02 acres)

Strait of Georgia

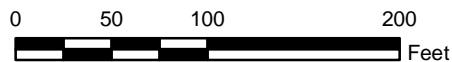
Source:  
 David Evans & Associates, 2010-07-14-svBSXpiti0006.dwg, 07/20/2010.  
 David Evans & Associates, 2010-04-14-svTPXpiti0006-DEGROSS.dwg,  
 07/20/2010.



				CLIENT: <b>PACIFIC INTERNATIONAL          TERMINALS, INC.</b>	
PROJECT:	PROPOSED GATEWAY PACIFIC TERMINAL	DWN BY:	SD	DATUM:	NAD83
TITLE:	PHOTO OF ABANDONED BELT CONVEYOR TO BE REMOVED	CHKD BY:	KD	REV. NO.:	1
		PROJECTION:	WA SP North, Ft.	SCALE:	1 inch=100 feet
				DATE:	FEBRUARY 2011
				PROJECT NO.:	091515338C-18-01
				FIGURE No.:	FIGURE 5-8





#### **5.3.4.3 Vessel Traffic and Moorage**

A vessel traffic analysis (VTA) is currently under development to model the impacts of vessel traffic resulting from operation of the Terminal.

#### **5.3.4.4 Marine Biological Communities**

To compensate for impacts to marine biological communities, mitigation would follow the guidance of the Settlement Agreement (1999) in addition to the below described mitigation measures. A more detailed analysis of the proposed Terminal on threatened and endangered and priority species will be provided in the forthcoming Biological Evaluation.

As compensation for wetland impacts and general impacts to the backshore community, a coastal lagoon habitat would be constructed east of Gulf Road, adjacent to the existing coastal lagoon. The constructed coastal lagoon would provide functions similar to those provided by the existing coastal lagoon. Creation of the additional proposed coastal lagoon habitat would potentially provide enhanced primary productivity and increased connectivity between upland habitats and the Strait of Georgia (AMEC 2011).

To further reduce shading and improve water quality, Pacific International Terminals would remove an abandoned creosote-piling conveyor at the southern boundary of the Terminal property (Figure 5-8). The existing conveyor system extends offshore approximately 170 linear feet. Eight creosote piles support the conveyor structure, and four steel piles encased in concrete at the base support the metal hopper on the shore. The total area of the abandoned pier is approximately 870 square feet (Figure 5-8). Removal of the existing pier would result in a reduction of 870 square feet of shading of nearshore habitat relative to existing conditions.

#### **5.3.4.5 Threatened and Endangered Species and Priority Species**

A more detailed analysis of the proposed Terminal on threatened and endangered and priority species will be provided in the forthcoming Biological Evaluation.

#### **5.3.4.6 Best Management Practices**

Best management practices would be developed and published in the Final Operations Plan for the facility. BMPs would include, among other management practices, plans for managing ballast water, implementation of a stormwater pollution prevention plan (SWPPP), and a marine spill avoidance and response plan.

During construction and operation of the facility, BMPs would be implemented for handling any material spills. In addition, state and federal requirements for managing stormwater discharge and all protocols to avoid vessel traffic collisions, interactions, and marine spills would be followed. If a

catastrophic spill occurred, private, local, state, and federal response action plans would be implemented to minimize damage.

Ballast water is regulated by WDFW under the Revised Code of Washington (RCW), Chapter 77.120, which applies to all vessels of 300 English gross tons or more carrying ballast water into the waters of the state after operating outside of the waters of the state. All vessels using the Terminal would file a ballast water report form at least 24 hours prior to arrival into waters of the state. Discharge of ballast water into waters would be allowed only after a prior open sea exchange, or if the vessel has treated ballast water (WDFW 2010). The Settlement Agreement (1999) contains provisions regarding ballast water, and the parties to that agreement are currently discussing how to implement those provisions best.

Marine directional lighting would be used to minimize lighting impacts on the marine environment. To provide illumination for safe access along the conveyor walkways and transfer towers, lighting would be provided using stanchion, ceiling, or wall-mounted 100-watt fixtures. Illumination for the working area on the shipping trestle and wharf would be provided by 400-watt floodlights mounted along the wharf conveyor.

## **5.4 WETLANDS, STREAMS, AND OTHER DRAINAGES**

This section describes the existing freshwater resources of the Gateway Pacific Terminal project area. Construction of the Terminal would result in:

- Unavoidable permanent and temporary loss of existing wetlands, streams, and other drainages in the project area; and
- Possible indirect effects to wetlands, streams, and ditches during construction or operation.

Mitigation to avoid, lessen, or compensate for these potential effects are included as part of the Terminal project. Compensation on-site is provided for minimized, unavoidable impacts. The need for additional compensatory mitigation, such as in-lieu fees, purchase of mitigation bank credits, or purchase and restoration of additional off-site areas, has been identified as a remaining obligation of the project.

A description of terrestrial vegetation and habitats was provided in Section 5.2.

### **5.4.1 Affected Environment**

The project area is drained via two coastal watersheds that empty into the Strait of Georgia. The project area has no hydrologic connection to interior mountain drainage. The majority of the project

area lies within and drains to the Gateway Pacific Terminal watershed; however, approximately 68 acres likely drains north to the Birch Bay Watershed (Figure 5-9).

#### **5.4.1.1 Birch Bay Watershed**

The existing drainage network for the project area is illustrated in Figure 5-10. The northwest corner of the project area (approximately 68 acres) is currently drained by Stream 3, which flows toward the northwest onto adjacent BP property (Figure 5-10). Stream 3 appears to connect downstream to the “*Industrial Tributary to Terrell Creek*,” which drains the western and northwestern portions of BP’s property. The hydrologic connection of Stream 3 to Terrell Creek has not been confirmed, but since no alternative is topographically apparent, it has been assumed that this connection occurs downstream on BP property.

In the project vicinity, the Birch Bay coastal watershed (31 square-miles) lies to the north and east and supports a variety of land uses, including heavy industry, residential, open space, and farming. The area includes the BP Refinery and associated industries lying immediately north, and Lake Terrell and its natural area lying due east of the project area.

Lake Terrell State Wildlife Refuge is a 1,500-acre wildlife area managed by the Washington Department of Fish and Wildlife as part of the Whatcom Wildlife Area for wintering waterfowl. The Whatcom Wildlife Area includes Lake Terrell (500 acres) and approximately 50 acres farmed for winter waterfowl forage (WDFW 2006). The westernmost extent of Lake Terrell lies less than a mile east of the Terminal’s eastern boundary and contains much of the Birch Bay basin’s wetlands. Planning efforts by Whatcom County and the Washington State Department of Ecology (Ecology) identified goals to meet natural resource objectives for maintaining the health of Birch Bay. The highest priority identified was to focus terrestrial and aquatic habitat rehabilitation efforts in the Terrell Creek stream corridor, and in areas within and adjacent to Lake Terrell (ESA Adolfson 2007).

The portion of the Birch Bay Watershed within the project area includes Wetland 1 (approximately 44 acres), which drains to Stream 3 (Table 5-10). A single 6-inch culvert beneath Aldergrove Road provides surface water connection to Stream 3 only during high flow periods (AMEC 2008). However, based on topographic gradients, Wetland 1 likely has subsurface hydrologic connectivity through the roadbed of Aldergrove Road.

#### **5.4.1.2 Gateway Pacific Terminal Watershed Characteristics**

The project area encompasses a major portion of an unnamed small coastal watershed (approximately 2,000 acres), which will be referred to in this document as the Gateway Pacific Terminal watershed. The Gateway Pacific Terminal watershed lies completely within the Puget Sound

**Table 5-10 Summary of Streams and Wetlands in the Project Vicinity that Drain into the Birch Bay Watershed**

Stream or Wetland ID	State of Washington Stream Type/ Wetland Rating <sup>1</sup>	Whatcom County Stream Type <sup>2</sup>	Water Flow Characteristic/ Classification	Location
Stream 3 (the "Industrial Tributary to Terrell Creek")	Ns	HCA 1c	Approximately 2,000 linear feet are adjacent to property. Relatively permanent water. Drains to Terrell Creek.	Drainage ditch on BP property adjacent to north side of Aldergrove Road.
Wetland 1	III	N/A	44.21-acre deciduous forested slope wetland.	Northwest corner of the project area. Drains toward Stream 3.

1 Source: Washington Administrative Code (WAC) 222-16-030 (Streams) and Wetland Rating system for Western Washington (Ecology 2006).

2 Whatcom County regulates streams as Habitat Conservation Areas (HCAs). HCA 1c is a non-fish bearing streams that have no known or potential use by anadromous or resident fish

lowlands and drains via two first-order streams to the Strait of Georgia. A coastal lagoon lies at the mouth of the streams at the Strait.



The Gateway Pacific Terminal watershed has experienced extensive disturbance over at least the past century due to road building, rail development, gas line and power line installation, homesteading, forest harvesting, and other development. Together these land uses have resulted in filling and ditching of wetlands, rerouting of streams, clear-cut logging and removal of other vegetation, and continuous grazing and hay production in some locations. However, land use has been less intensive in the last 20 years than historically because homesteads are no longer present.

One reach of Stream 1 (WRIA # 01.0100) and all of Streams 3, 4, 5, 6, and 7 flow in roadside ditches in the project area (see Figure 5-10 for locations). In addition, nine other drainages occur as roadside ditches. The streams have continuous flow for at least three months of the year and are considered relatively permanent waterways (RPWs). Other relatively permanent waterways include Ditches 1, 3, 4, 7, 8, and 9. All other drainages are considered non-RPWs. Table 5-11 provides summary information on streams in the project area. No determination has been made yet as to which roadside streams meet the State of Washington’s definition for streams. Stream 1 has been assigned a number under Washington’s Water Resources Inventory Area (WRIA) stream-naming convention (Stream 01.0100), Stream 2 is numbered 01.0101; all other streams, and ditches are technically unnamed and unnumbered but are herein numbered to facilitate discussion.

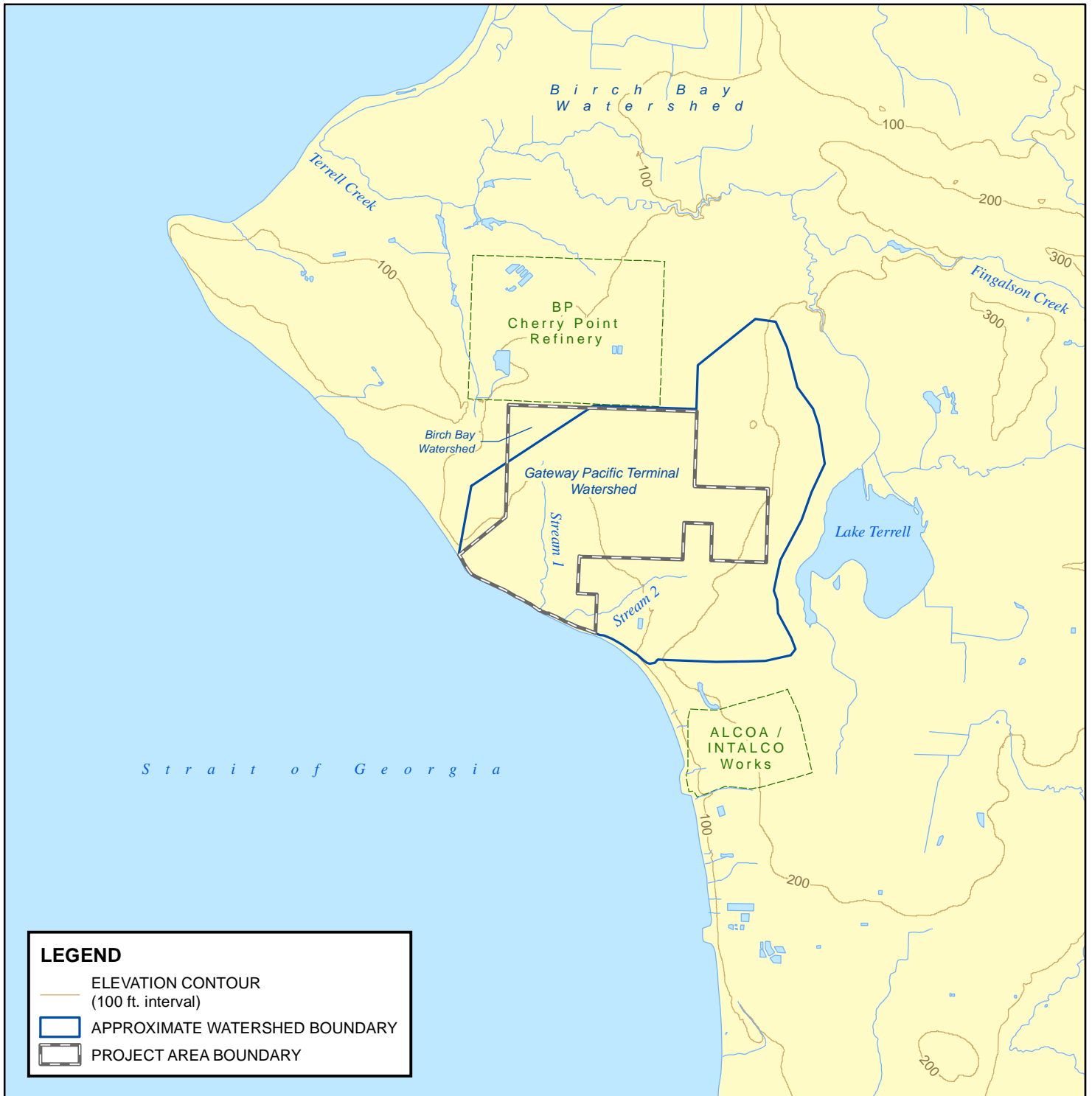
Characteristics of these streams are described in more detail below.



**LEGEND**

-  ELEVATION CONTOUR (100 ft. interval)
-  APPROXIMATE WATERSHED BOUNDARY
-  PROJECT AREA BOUNDARY

Source:  
 Elevation Contours from Whatcom County:  
<http://www.co.whatcom.wa.us/pds/planning/gis/gisdata.jsp>

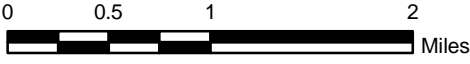

				CLIENT: <b>PACIFIC INTERNATIONAL TERMINALS, INC.</b>	
PROJECT: <b>PROPOSED GATEWAY PACIFIC TERMINAL</b>		DWN BY: SD	DATUM: NAD83	DATE: FEBRUARY 2011	
TITLE: <b>WATERSHEDS WITHIN THE GATEWAY PACIFIC TERMINAL PROJECT SITE</b>		CHK'D BY: RH	REV. NO.: 1	PROJECT NO.: 091515338C-18-01	
		PROJECTION: WA SP North, Ft.	SCALE: 1 inch=1 mile	FIGURE No.: <b>FIGURE 5-9</b>	



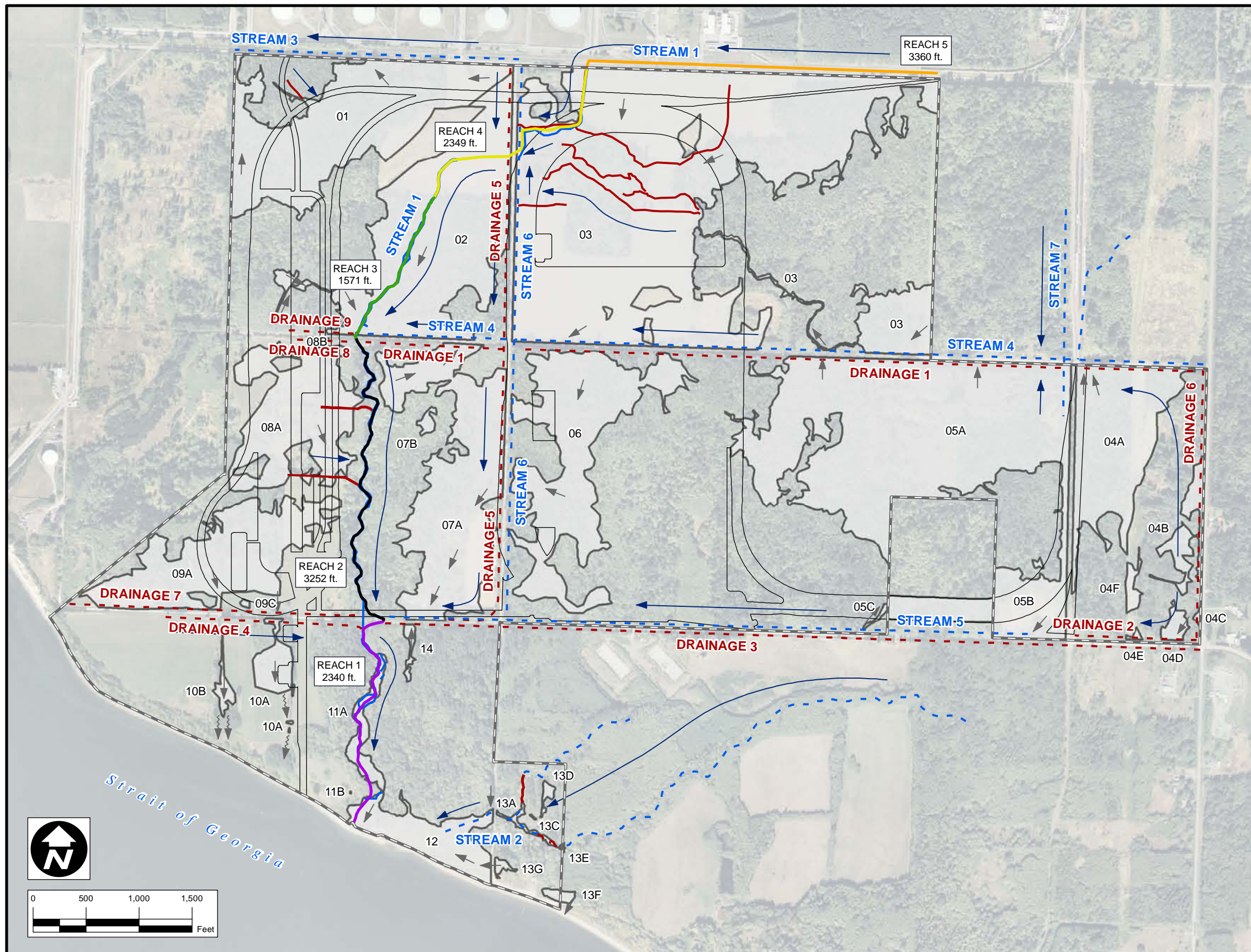

**LEGEND**

- - - APPROXIMATE DRAINAGE
- SURVEYED DRAINAGE
- - - APPROXIMATE STREAM COURSE
- SURVEYED STREAM COURSE
- ➔ STREAM AND DRAINAGE FLOW DIRECTION
- ➔ WETLAND FLOW DIRECTION

**STREAM 1:**

- REACH 1
- REACH 2
- REACH 3
- REACH 4
- REACH 5

- 05A EXISTING WETLAND AREA
- PROPOSED DEVELOPMENT FOOTPRINT
- PROJECT AREA BOUNDARY

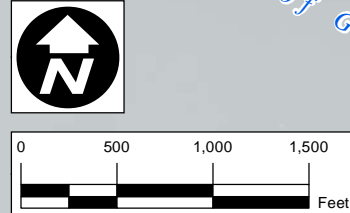

 Pacific International Terminals <small>A Carris Enterprise</small>	CLIENT: <b>PACIFIC INTERNATIONAL TERMINALS, INC.</b>	DWN BY: SD CHK'D BY: KD DATUM: NAD83 PROJECTION: WA SP North, Ft. SCALE: 1 inch = 1,000 feet	PROJECT: <b>PROPOSED GATEWAY PACIFIC TERMINAL</b>	DATE: FEBRUARY 2011 PROJECT NO.: 091515338C-18-01 REV. NO.: 1 FIGURE NO.: FIGURE 5-10
	TITLE: <b>EXISTING CONDITIONS          STREAM NETWORK, WETLANDS, AND          HYDROLOGIC FLOW</b>			





### Stream 1

Table 5-12 describes the characteristics of Stream 1 by individual stream reach (see Figure 5-10). Stream 1 is approximately 2.4 miles long in the project vicinity and drains a total of approximately 800 acres, flowing from its headwaters northwest of the project area via roadside ditches, pastures, and natural drainage. It is fed by surface runoff through excavated roadside ditches and isolated channels within wetlands, and in some places, by surface sheet flow. Groundwater seeps appear to be important for base flow support in Reaches 1 and 2.

According to the definition of properly functioning condition, the lowest reach of Stream 1 has indicators of properly functioning conditions with regard to width-to-depth ratio and large woody debris (LWD); however, other characteristics are lacking. Stream 1 provides limited fish habitat because of a blocking culvert at Reach 1, intermittent flow, few high-quality pools, lack of LWD and spawning gravels, poor water quality attributed to sediment load, and garbage in the stream. The only fish species identified within the stream channel was the three-spine stickleback (*Gasterosteus aculeatus*), schools of which were located in Reach 1.

Restoration opportunities identified along Stream 1 include replacing culverts to permit fish passage further upstream, rerouting flows from roadside tributary ditches to wetlands, restoring adjacent wetlands and riparian areas, and possibly installing LWD and habitat gravels where needed.

### Stream 2

Stream 2 is approximately 1 mile long, with about 1,160 linear feet located on the Pacific International Terminal property, and the remaining area on adjacent, privately owned parcels. Stream 2 drains from the eastern portion of the Gateway Pacific Terminal watershed and generally flows toward the southwest. A short tributary flowing from the northeast (Stream 2A) joins the primary channel of Stream 2 at a location approximately 400 feet east of Gulf Road. The stream then flows southwest through a culvert under Gulf Road to Wetland 12, a coastal lagoon.

Although the area has been mapped as a priority area due to its location, the habitat value of Stream 2 and its tributary is relatively low because it has been disturbed by development over many years, including industrial, agricultural, and residential uses. At least three areas of abandoned foundations and piles of debris are present within the riparian area of the lower reach. Because of previous development in this area, much of the vegetation has been disturbed and includes a large component of Himalayan blackberry. Approximately 250 feet east of the project area, on an adjacent property, an old stock pond with an earthen dam across the main channel eliminates continuous flow in the stream corridor. Upstream of the stock pond, the stream lies in a steep-sided ravine, and the riparian area is narrow but forested. The stream drains approximately 80 acres of active pasture area, with cattle fenced from the stream and its ravine.

**Table 5-11 Stream Characteristics in the Gateway Pacific Terminal Watershed**

Stream ID	State of Washington Stream Type <sup>1</sup>	Whatcom County Stream Type <sup>2</sup>	Water Flow Characteristic	Location
Stream 1	F	HCA 1b	Relatively permanent waterway. Begins as roadside ditch at north side of Aldergrove Road.	First-order stream. Flows mainly south through the project area.
Stream 2	Ns	HCA 1b	Relatively permanent waterway	First-order stream. Flows southwest in the southernmost portion of the project area. Most of stream on adjacent property. Has several small tributaries (not mapped).
Stream 4	Ns	HCA 1c	Relatively permanent waterway	Drainage ditch on the north side of Lonseth Road
Stream 5	Ns	HCA 1c	Relatively permanent waterway	Drainage ditch on the north side of Henry Road
Stream 6	Ns	HCA 1c	Relatively permanent waterway	Drainage ditch on the east side of Gulf Road
Stream 7	Ns	HCA 1c	Relatively permanent waterway	Drainage ditch located between Henry Road and Lonseth Road along the west side of the Custer Spur rail embankment in the Elliot Yard

1 Source: WAC 222-16-030 (Streams)

2 Whatcom County regulates streams as Habitat Conservation Areas (HCAs). HCA 1b are other fish bearing streams that do not meet the definition of shorelines of the state but have known or potential use by anadromous or resident fish species; HCA 1c are non-fish bearing streams that have no known or potential use by anadromous or resident fish.

**Roadside Streams and Drainages**

Roadside ditches within the project area were constructed to convey runoff, keep the road subbase dry, and provide a transition from public roads to private property. While all of the roadside conveyances produce a defined channel or bed, none of the streams or ditches occurs in locations where natural streams existed before human alteration. According to correspondence with Whatcom County, the roadside ditches are mowed annually and excavated approximately once every three years (AMEC in preparation). Sheet flow from either adjacent areas or road surfaces is the source for flow in the roadside ditches. There are only four or five locations in the entire project area where other small ditches drain into the roadside ditches. Water in the roadside ditches flows directly to Stream 1 in almost all cases. The geometry of nearly all of the ditches is trapezoidal, with relatively sharp corners subject to erosion. The dimensions of the ditches are variable, with depths ranging from 0.8 to 3.9 feet. The average depth of roadside ditches is 2.4 feet, while the average depth of roadside streams is 2.2 feet.

**Table 5-12 Summary of Stream 1 Conditions by Reach**

Reach Number	Length (linear feet)	Description (see Figure 5-10)	Characteristics	Stream Function: High, Medium, Low (Based on Field Observations)
1	2,340	Stream mouth to Henry Road	Flows through a ravine, defined by steep slopes on both stream banks with a canopy of red alder and a shrub understory dominated by willow and twinberry. Riverine wetlands are characteristic along the stream.	High
2	3,252	Henry Road to Lonseth Road	Narrow streambed with less emergent or aquatic vegetation than Reach 1, without riverine wetlands. The riparian community is characterized by a canopy of red alder with shrubs, including salmonberry and snowberry ( <i>Symphoricarpos albus</i> ), in the understory.	High
3	1,571	Upstream of Lonseth Road to the pasture South of Aldergrove Road	Shallow streambed, poorly defined in places, not in a ravine. Travels through Wetland 2 (PFO). No fish habitat, but provides water quality function.	Medium
4	2,349	From the pasture to Aldergrove Road	Ditch in active pasture (Wetlands 1 and 3). Not protected from grazing. In culvert under Powder Plant Road.	Low
5	3,360	From culvert at Aldergrove Road to property boundary	Roadside ditch on north side of Aldergrove Road. Receives runoff from refinery and roadway.	Low

PFO = Palustrine forested wetland type.

Vegetated roadside ditches have the potential to provide water quality benefits, but they may also transport sediments and pollutants. Therefore, roadside ditches may provide both positive and negative effects on downstream water quality. Dense herbaceous vegetation present in the majority of the ditches has the potential to reduce the contaminant load of roadside runoff. Direct disturbance to roadside ditches that may impair their water quality performance is not widespread, as ditch maintenance occurs only every few years. During a stream survey in 2010, approximately 50 percent of the ditch segments exhibited trash, all classified as minor. Siltation was evident in 83 percent of ditches evaluated and in all of the roadside streams.

### Other Ditches

Other small, unnamed ditches occur in the project area, mainly in hayfields and pasture area wetlands. These other ditches are generally less than 3 feet deep and 4 feet wide and are not regularly maintained. They convey water for more than three months of the year. Near hayfields, these ditches have narrow riparian areas with blackberry, rose, and young alder vegetation. In the pasture areas, the ditches are not protected from cattle, and thus the ditches and riparian areas have grazed herbaceous vegetation.

## **Wetlands**

A Jurisdictional Determination by the US Army Corps of Engineers (USACE) issued on March 5, 2009, confirmed the extent and location of delineated wetlands on the Pacific International Terminals property. The USACE also determined that all aquatic features, including wetlands, streams, and ditches, on the Pacific International Terminals property are jurisdictional because they either abut or are adjacent to unnamed tributaries of the Strait of Georgia, a traditional navigable water. More details on existing wetland conditions can be found in the *Wetland Determination and Delineation Report* (AMEC 2008). It is assumed that any wetlands on Parcel 14 (Figure 1-3) would also be considered jurisdictional.

Wetlands comprise approximately 530.6 acres, or approximately 49 percent, of the Pacific International Terminals property (Table 5-12). Hydrogeomorphic wetland classes present include depressionnal, slope, and riverine. Red alder forested wetlands (PFO) are most common, followed by wet pastures, hayfields, and mowed utility corridors (PEM), with a smaller amount of dense rose/blackberry/snowberry shrub wetland (PSS).

Approximately 513 acres are rated as Category III wetland and 1.1 acre is rated as Category IV (Wetland 4F). Category I and II Wetlands totaled about 15 acres. A barrier dune separates Wetland 12 from the beach and shore and the area was classified as an estuarine emergent wetland that grades in the landward direction to a forested palustrine wetland system. This wetland is also referred to as a coastal lagoon.

Wetland characteristics and ratings are summarized in Table 5-13.

### ***Water Quality Functions***

Wetlands in the project area have low to moderate potential to provide water quality functions. A majority of the wetlands that are forested lack defined outlets, which help to slow and detain water and allow sediments and pollutants to settle out and become assimilated into the soil column. However, the presence of large wetland pastures that are grazed or mowed and the lack of clay or organic soils reduce the overall ability of on-site wetlands to perform water quality functions.

Due to the presence of paved roads and grazed pastures, many wetlands received higher ratings based on the opportunity to perform water quality functions. However, the deep roadside streams and drainages collect a majority of the surface water runoff from the adjacent wetlands. While Wetlands 2 and 3 have the opportunity to perform water quality functions as they are pastures, their low vegetation biomass reduces their actual water quality functional rating to low.

**Table 5-13 Characteristics and Ratings of Wetlands on the Pacific International Terminals Property**

Wetland Name	Hydrogeomorphic Class	Wetland Area by Cowardin <sup>1</sup> Classification			Rating <sup>2</sup>	Total Area (acres)
		Palustrine Scrub-Shrub (acres)	Palustrine Emergent (acres)	Palustrine Forested (acres)		
1	Flats/Depressional	1.3	5.1	37.8	III	44.2
2	Slope	5.0	11.3	37.0	III	53.2
3	Slope	15.1	72.3	63.2	III	150.7
4A	Slope	2.2	5.0	19.5	III	26.6
4B	Depressional	0.7	0	3.7	III	4.4
4C	Depressional	0.1	0	0.1	III	0.2
4D	Slope	0	0	1.3	III	1.3
4E	Slope	0	0.2	0	III	0.2
4F	Slope	0.3	0.8	0	IV	1.1
5A	Slope	8.6	3.2	83.4	III	95.2
5B	Depressional	0	0	0.1	III	0.1
5C	Slope	0	0	0.2	III	0.2
6	Slope	0	0	36.9	III	36.9
7A	Slope	2.1	3.5	34.5	III	40.1
7B	Depressional	0	0	0.6	III	0.6
8A	Slope	9.8	5.9	9.1	III	24.8
8B	Depressional	0.1	0	0	III	0.1
9A&C	Slope	6.9	8.6	12.7	III	28.2
10A	Slope	0.5	0.2	3.1	III	3.7
10B	Depressional	0.6	0.3	0.3	III	1.1
11A	Riverine	0	0	3.5	I	3.5
11B	Depressional	<0.1	0	0	III	<0.1
12	Depressional <sup>3</sup>	4.7	0.7	5.8	I	11.2
13A	Riverine	0	0	0.6	I	0.6
13C	Depressional	0	0	<0.1	III	<0.1
13D	Slope	0	0	0.4	III	0.4
13E	Riverine	0	0	0.1	I	0.1
13F	Depressional	0	0	0.6	III	0.6
13G	Depressional	0	0	0.4	III	0.4
14	Depressional	0	0	0.7	III	0.7
<b>Total Wetland Area</b>		<b>57.9</b>	<b>117.1</b>	<b>355.6</b>		<b>530.6</b>

1 Cowardin et al. 1979.

2 Hruby 2004.

3 Estuarine, not palustrine wetland

Surface water quality within the project area is affected by sheet-flow runoff from roads to adjacent open ditches. The extent of roadway area and traffic volume are relatively low in this area. Water quality is degraded during periodic roadside ditch maintenance. Vegetation mowing in and adjacent to the ditches occurs on a 1- to 2-year cycle, and ditch cleaning on about a 5-year cycle (currently). Trash is almost always observed in ditches. Water quality is also affected by grazing in the active pasture areas.

### ***Hydrologic Functions***

Wetlands in the project area have low to moderate potential to provide water quality functions. A majority of the wetlands that are forested lack defined outlets and results in detaining water. The presence of large wetland pastures that are grazed or mowed and the lack of clay or organic soils reduce the overall ability of on-site wetlands to perform water quality functions. Due to the presence of paved roads and grazed pastures, many wetlands received higher ratings based on the opportunity to perform water quality functions. However, the deep roadside streams and drainages collect a majority of the surface water runoff from the adjacent wetlands. While Wetlands 2 and 3 have the opportunity to perform water quality functions as they are pastures, their low vegetation biomass reduces the actual water quality functions.

### ***Habitat Functions***

Wetlands at the Terminal project site provide moderate to high habitat functions According to the *Washington State Wetlands Rating System for Western Washington* With the exception of Wetland 4F, all wetlands on site scored 10 or higher for habitat functions, and 10 wetlands scored 20 or higher (Wetlands 2, 3, 5A, 5C, 7A, 8A, 9A, 11A, 13A, and 13E). Adjacent roads and land uses prohibit undisturbed corridors and connections to other habitats and eliminate wetland buffers. However, large forested wetlands with multiple vegetation layers provide numerous habitat niches for a variety of species. Wetland 11A provides the highest habitat functions, and coincides with WDFW and Whatcom County priority riparian habitats along Streams 1.

## **5.4.2 Potential Development Effects**

Impacts to wetlands, streams, and ditches have been avoided and minimized to the extent practicable, while maintaining the ability and area to develop and operate an intermodal Terminal. Development of the Terminal would result in direct permanent impacts to 140.6 acres of wetlands and 12,814 linear feet (approximately 50,850 square feet) of streams and ditches (Figure 5-11).

### **5.4.2.1 Streams**

The layout of the Terminal would eliminate some existing roadways and their associated roadside ditches. Reach 4 of Stream 1 crosses an active pasture, and the area would be filled for railroad embankment. Table 5-14 summarizes other likely direct effects to streams and roadside drainages.

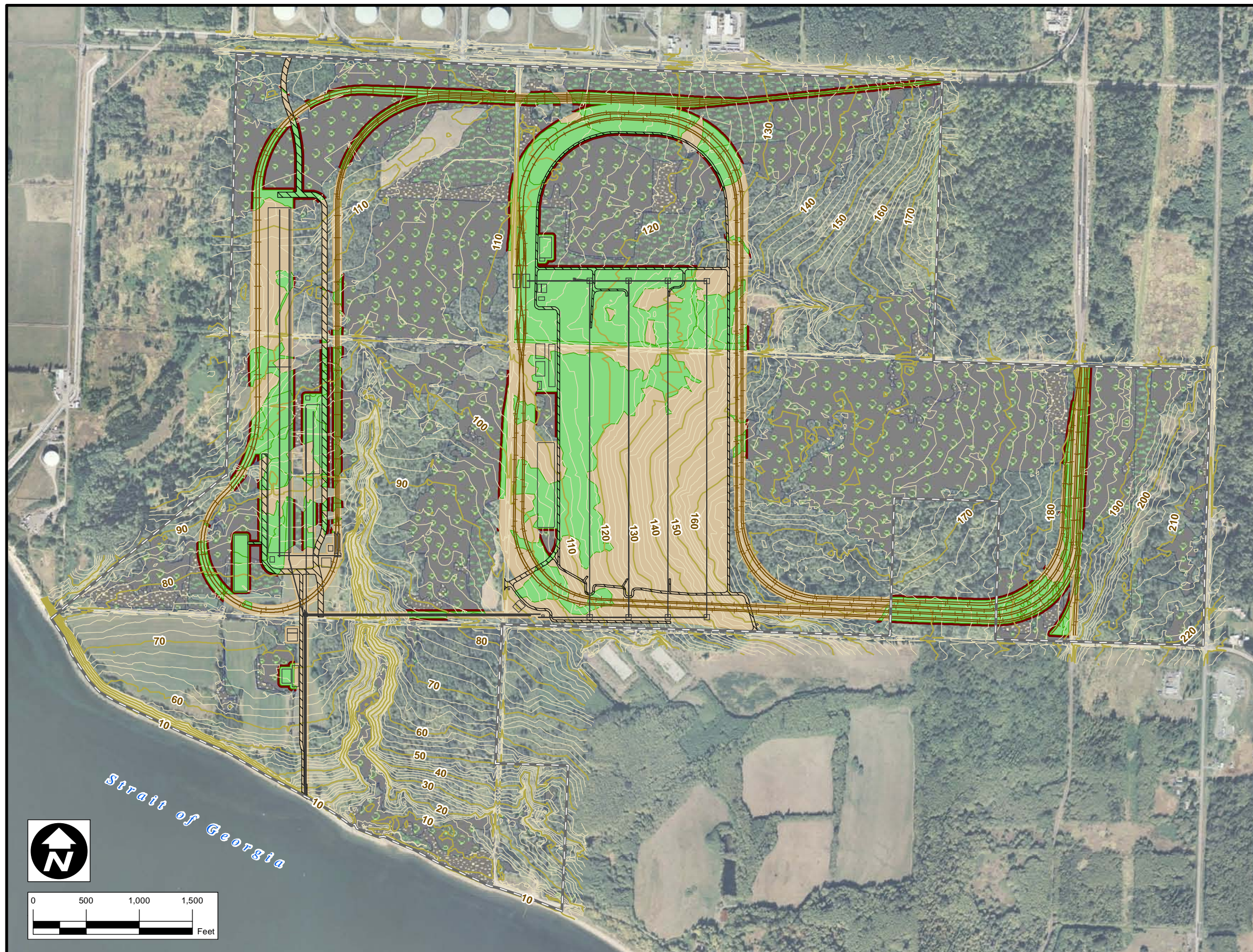

**LEGEND**

- CURRENT ELEVATION CONTOUR (10 ft. interval, NAVD88 datum)
- CURRENT ELEVATION CONTOUR (2 ft. interval, NAVD88 datum)
- RAILROAD
- ROAD

**WETLAND IMPACT AREA (161.86 acres):**

- PERMANENT (140.60 acres)
- TEMPORARY (21.26 acres)
- DEVELOPMENT FOOTPRINT
- PROJECT AREA BOUNDARY

**VEGETATION TYPE:**

- FRESHWATER FORESTED WETLAND (PFO)
- FRESHWATER SHRUB WETLAND (PSS)
- FRESHWATER EMERGENT WETLAND (PEM)

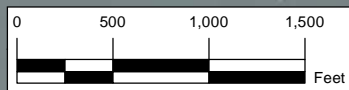

Source:  
 Ausenco Sandwell, 154199-A100-42S01.dwg (Rev. I), 12/09/2010.  
 David Evans & Associates, 2010-04-14-svTPXpiti0006-DEGROSS.dwg, 07/20/2010.



CLIENT:  
**PACIFIC INTERNATIONAL TERMINALS, INC.**

DWN BY: SD  
 CHK'D BY: RH  
 DATUM: NAD83  
 PROJECTION: WA SP North, Ft.  
 SCALE: 1 inch = 1,000 feet

PROJECT:  
**PROPOSED GATEWAY PACIFIC TERMINAL**

TITLE:  
**SUMMARY OF DIRECT FILL IMPACTS  
 TO WETLANDS WITHIN THE  
 GATEWAY PACIFIC TERMINAL PROJECT SITE**

DATE: FEBRUARY 2011  
 PROJECT NO.: 091515338C-18-01  
 REV. NO.: 1  
 FIGURE NO.: FIGURE 5-11





**Table 5-14 Impacts to Gateway Pacific Terminal Streams and Drainages**

<b>Stream/Drainage – Impact location</b>	<b>Development Phase/Location</b>	<b>Impact Description/Flow Routing</b>	<b>Impact (linear feet)</b>	<b>Estimated Area of Fill (square feet)</b>
Stream 1 – Reach 4 in active pasture (Wetland 3)	Stage 1/ East Loop and portion of West Loop	Stream would be piped under East Loop and West Loop rail embankments in approximately same location as current stream.	774	7,737
Stream 4 – Westward flowing roadside ditch on north side of Lonseth Road	Stage 1/East Loop	Rail embankment and interior of East Loop; flows rerouted starting from upstream location into historic channel. Small portion of the stream would be route via a culvert.	2,240	8,958
Drainage 1 – West-flowing ditch on south side of Lonseth Road.	Stage 1/East Loop	Rail embankment and interior of East Loop; flows rerouted starting from upstream location into historic channel (same as Stream 4). Small portion of reroute in culvert.	2,144	6,433
Stream 5 – Westward flowing roadside ditch on north side of Henry Road	Stage 1/East Loop	Western portion piped in same location. Eastern portion flows diverted to Wetland 5.	488	1,951
Drainage 6 – Westward flowing roadside ditch south side of Lonseth Road, east of Custer Spur	Stage 1/East Loop	Fill for culvert beneath rail embankment.	57	114
Stream 6 – Southward flowing roadside ditch on east side of Powder Plant Road	Stage 1/East Loop	Fill for rail embankment. Flow combined with Drainage 5.	4,281	17,125
Drainage 5 – Southward flowing roadside ditch on west side of Powder Plant Road	Stage 1/East Loop	Fill for rail embankment. Flows rerouted to adjacent wetland.	1,459	4,370
Drainage 7 – Eastward flowing roadside ditch on north side of Henry Road, West of Stream 1	Stage 2/West Loop	Culvert under rail embankment; western portion restored to wetland when roadbed removed.	1,001	3,003
Drainage 4 – Eastward flowing roadside ditch on south side of Henry Road, west of Stream 1	Stage 2/West Loop	Culvert under rail embankment (same as Drainage 7); western portion restored to wetland when roadbed removed.	83	290
Drainage 8 – Eastward flowing roadside ditch on south side of Lonseth Road	Stage 2/West Loop	Culvert under rail bed, eastern portion restored to wetland when roadbed removed	143	428
Drainage 9 – Eastward flowing roadside ditch on north side of Lonseth Road	Stage 2/West Loop	Culvert (same as Drainage 8), eastern portion restored to wetland when roadbed removed	144	433
<b>Total</b>			<b>12,814</b>	<b>50,850</b>

### 5.4.2.2 Wetlands

Direct permanent impacts are expected to total 140.6 acres. See Figure 5 11 for locations of these impacts. Impacts would result from earth moving conducted to establish grades suitable for development. Earth moving would include both filling and grading or cutting.

### 5.4.3 Temporary Wetland and Stream Effects

Temporary direct effects to wetlands and streams would occur during construction. Temporary impacts during construction are estimated to include 21.3 acres of wetlands and 4,532 linear feet (16,899 square feet) of streams and ditches. Temporary impacts would result from removal of wetland vegetation and soil disturbance in a zone that extends 20 feet beyond the outer edge of the proposed permanent infrastructure. Vegetation would need to be removed to stage construction equipment and to install silt fencing. The temporarily disturbed area would define the limits of construction and provide maneuvering space for earth-moving and other construction machinery. Temporary disturbance would also result in areas where trenching would be required through wetlands for the installation of water and electrical utilities. Following construction, soil in these areas would be re-graded to the natural topography, and the areas would be replanted with appropriate native forest and shrub wetland vegetation. A summary of the temporary direct impacts to wetland by vegetation type is provided in Table 5-15.

**Table 5-15 Temporary Wetland Impacts**

Wetland ID	PEM <sup>1</sup>	PFO	PSS	Total
1	0.31	3.72	0.0	4.02
2	0.25	0.50	0.13	0.89
3	3.71	1.76	0.48	5.95
4A	0.0	0.72	0.00	0.72
5A	0.35	0.58	0.34	1.28
5B	0.0	0.01	0.0	0.01
5C	0.0	0.02	0.0	0.02
6	0.0	0.64	0.0	0.64
7A	0.01	0.92	0.13	1.06
8A	0.53	1.29	1.28	3.10
8B	0.01	0.0	0.02	0.03
9A	1.37	0.79	0.24	2.40
10A	0.0	0.23	0.00	0.23
Parcel 14	0.0	0.91	0.0	0.91
Total	6.54	12.09	2.64	21.26

1 Cowardin Classifications are as follows: PEM=Palustrine emergent wetland, PFO= Palustrine Forested Wetlands, PSS= Palustrine scrub-shrub wetland. Cowardin et al. 1979.

#### **5.4.4 Potential Operational Effects**

Potential impacts to streams, ditches, and wetlands during operations have been avoided or minimized to the extent feasible through Terminal design or implementation of appropriate operations controls. During operations of the facility, the greatest risks to wetlands, streams and drainages would be indirect effects to water quality or hydrologic functions, as well as effects to wetland and stream habitat from operational noise or light.

##### **5.4.4.1 Potential Negative Changes to Hydrologic Functions**

The risk of downstream flooding, scour, channel degradation, and loss of habitat has been mitigated by using appropriately sized stormwater facilities and a large open-water area that would replace hydrologic functions and avoid downstream effects.

One important aspect of a development's effect on downstream hydrologic systems is the amount of new impervious surface that occupies the watershed. Precipitation on impervious surfaces results in increased runoff, which triggers a cascade of effects. Lack of effective controls on runoff from impervious surfaces could risk degradation of downstream systems by increased "flashiness" of the hydrologic functions. The Terminal design incorporates appropriate stormwater collection and retention from impervious surfaces to both treat runoff to improve water quality and control runoff to modulate hydrologic response to storm events.

#### **5.4.5 Proposed Design Features Intended to Reduce Impacts**

The Terminal's currently proposed layout, with two independent rail loops and commodity storage areas, would best meet the project's purpose and need. The proposed project avoids and minimizes impacts to wetlands, streams, and ditches to the extent possible, rectifies temporary impacts where practical, and provides compensation for minimized, unavoidable negative effects to wetland streams, ditch areas, and their functions. Mitigation was developed following the latest guidance and information available. *The Gateway Pacific Terminal Preliminary Conceptual Compensatory Mitigation Plan* (AMEC 2011) provides further details, and a summary is presented below.

##### **5.4.5.1 Avoidance**

Site layout alternatives were generated in the 1990s and evaluated for potential impacts. One of these earlier project designs included a rail line crossing the Stream 1 ravine, which would likely have required filling for construction of the embankment within the ravine. Operation of trains across the ravine may have resulted in other indirect impacts. More recent designs developed before efforts to avoid wetland and stream areas were undertaken included estimates of up to 180 acres of direct wetland impacts.

In the currently proposed design, Terminal infrastructure has been repositioned to be more densely developed, leaving large areas of the property undisturbed. Priority wildlife habitats are present in the project area and a goal was set to avoid these areas to the extent practical. Importantly, the current design avoids the highest functioning wetland and stream systems in the project area. These design efforts include the following avoidance strategies.

- Impacts have been avoided at:
  - Reaches 1, 2, ,3, and 5 of Stream 1;
  - All of Stream 2; and
  - All parts of Category I Wetlands (11A, 12, 13A or 13E).
- Direct permanent impacts to Category III Wetlands 4B, 4C, 4D, 4E, 4F, 7B, 10B, and 14 have been avoided completely.
- In total, 390.1 acres of wetlands in the project area will be avoided by development.
- The shoreline area has been avoided, with the exception of the trestle area.
- Terminal infrastructure has been located as far from these sensitive and priority habitat areas as possible.

#### **5.4.5.2 *Minimization***

The current Terminal design incorporates the following appropriate and practicable measures to minimize those impacts to wetlands, streams, and ditches that cannot be avoided:

- Rail lines have been aligned to minimize impacts to wetlands, streams, and drainages while maintaining the length and turning radius required for trains to enter and exit the Terminal facility safely and efficiently.
- Storage areas have been grouped inside rail loops. This has concentrated development at the Terminal within defined areas.
- Facilities have been shifted away from the shoreline (compared to the 1996/1997 design), which allows for preservation and improvement of the critical areas proximate to shoreline priority habitats.
- Development of terminal infrastructure in a single construction period would avoid repeated disturbance to areas over time.
- Implementation of all compensatory mitigation during Stage 1 construction would provide up to 2 years of mitigation benefit prior to potential impacts, thereby minimizing temporal loss and reducing the potential effects of compensation failure.

- Extra consideration has been given to preserving watershed functions, especially those that protect downstream functions of Stream 1. Potential effects to hydrology and water quality have been minimized through the careful design of stormwater facilities that provide water quality protection and integrate hydrologic functions with natural stream courses.
- Temporary construction impacts will be minimized by locating construction laydown and staging areas in areas that will ultimately be developed, using high-visibility fencing to demarcate construction limits, and designing and enforcing an effective construction stormwater plan.

The Terminal was designed to avoid and minimize impacts to wetlands and streams to the extent practicable. Development impacts to wetlands, streams, and drainages would be expected to result in water quality deterioration if development was poorly controlled within the watershed. However, an overall improvement in water quality is expected because the Terminal development would:

- Permanently remove grazing impacts from more than 100 acres,
- Provide effective stormwater treatment and management systems, and
- Reroute almost all roadside streams and drainages into new or restored natural stream systems.

Impacts to hydrologic functions are compensated through engineering of the Terminal that integrates hydrologic and water quality systems and a mitigation design that works to maintain and improve this important function.

#### **5.4.5.3 Compensation**

Compensatory mitigation for unavoidable, minimized impacts to wetlands, streams, and drainages is proposed at multiple on-site locations (Figure 5-12). The compensatory mitigation strategy was developed using a watershed approach. Compensation was designed within a holistic framework, with the primary aim to address the highest needs for the watershed when viewed as a connected, interactive aquatic ecosystem. The design approach followed federal guidance prescribed in the *Compensatory Mitigation for Losses of Aquatic Resources; Final Rule* (Federal Register 2008). In the guidance, agencies were directed to evaluate proposed compensation in light of watershed analysis, considering landscape position and sustainability, the ability to provide a suite of functions, and the ability to ensure that the level of analysis is commensurate with impacts.

The compensatory mitigation strategy for impacts to wetlands and streams was developed using a watershed approach for the Gateway Pacific Terminal Watershed, from its headwater wetlands to the Strait of Georgia.

Three mechanisms are available for providing compensatory mitigation: permittee-responsible mitigation, mitigation banking, and in-lieu fee mitigation. The regulation encourages using mitigation bank credits and in-lieu fee credits instead of permittee-responsible compensatory mitigation when such credits are available. Currently, we know of only one possible source for mitigation bank credits. In addition, although in-lieu fee programs are being planned, no existing in-lieu fee program is available for the Terminal area as of February 2011.

The following paragraphs describe a permittee-responsible approach for the Gateway Pacific Terminal for on-site compensation. Other alternative approaches to complete the compensation will be developed as the design process moves forward.

In addition to guidance from state and federal agencies, Whatcom County Code provides guidance on appropriate compensation ratios for impacts to wetlands (Table 5-16).

**Table 5-16 Approximate Area of Compensatory Mitigation Required For Category III Wetland Impacts by Whatcom County**

Compensatory Mitigation Requirements Mitigation Type	Compensation area needed for 1 acre of Impact area
Creation	2:1
Rehabilitation	4:1
Enhancement	8:1
Preservation (Category I and II only)	20:1

Source: Whatcom County Municipal Code (16.16.680)

The proposed compensatory mitigation would consist of on-site wetland creation and enhancement, riparian enhancement, stream relocation, fish passage improvements, forest preservation, forest enhancement, and stormwater quality and quantity control (Figure 5-12).

Unavoidable minimized impacts to wetlands, streams, and ditches would be compensated by:

- creating wetland areas to provide no net loss of wetland area in the watershed;
- providing replacement hydrologic and water quality functions high in the watershed;
- rehabilitating/restoring degraded wetlands wherever feasible to provide hydrologic, water quality, and habitat functions; and
- rerouting streams and ditches to increase riparian and in-stream functions.

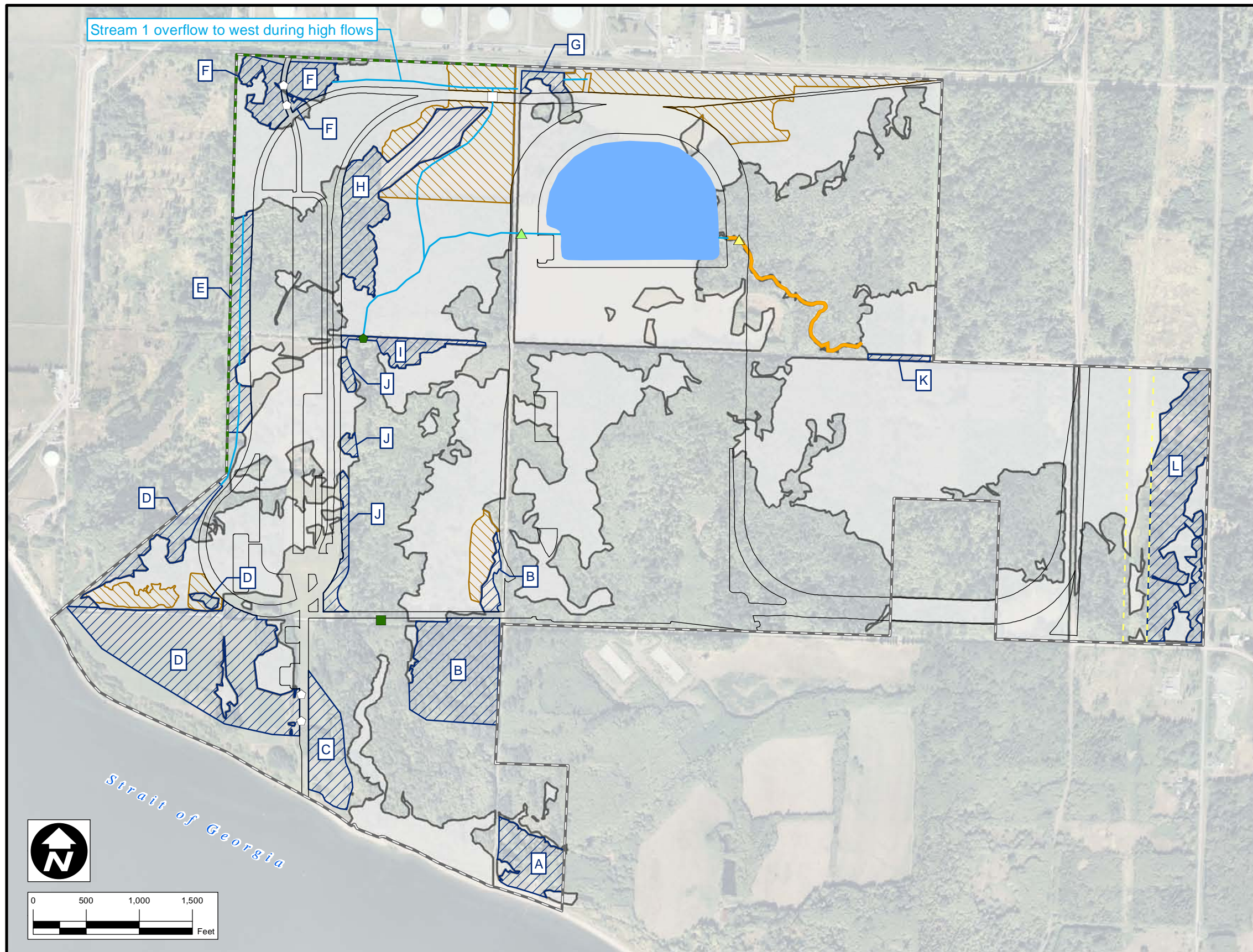

Stream 1 overflow to west during high flows

**LEGEND**

- ▲ CULVERT INFLOW TO POND
- ▲ CULVERT OUTFLOW FROM POND
- CULVERT UNDER RAIL LINES
- ◇ CULVERT UNDER ROAD
- CULVERT ENHANCEMENT TO IMPROVE FISH PASSAGE
- ◆ CULVERT REMOVAL & STREAM RESTORATION
- - - CONIFER ENHANCEMENT (6,530 lf)
- PROPOSED NEW STREAM/DITCH (8,793 lf)
- ENHANCEMENT OF EXISTING STREAM WITH 15' RIPARIAN BUFFER ENHANCEMENT ON EACH SIDE (2,300 lf, 1.6 acres of riparian planting)
- ▨ PROPOSED WETLAND ENHANCEMENT AREA (49 acres)
- ▩ PROPOSED WETLAND CREATION AREA (136 acres)
- PROPOSED WATER QUALITY POND WITH 100' BUFFER (36 acres)
- ▭ EXISTING WETLAND AREA
- - - APPROXIMATE UTILITY RIGHT-OF-WAY (location is approximate and will need to be field verified)
- ▭ PROPOSED DEVELOPMENT FOOTPRINT
- ▭ PROJECT AREA BOUNDARY

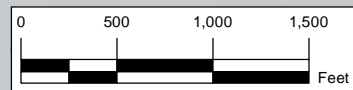

Source: Ausenco Sandwell, 154199-A100-42S01.dwg (Rev. I), 12/09/2010.



CLIENT:  
**PACIFIC INTERNATIONAL TERMINALS, INC.**

DWN BY: SD  
 CHK'D BY: KD  
 DATUM: NAD83  
 PROJECTION: WA SP North, Ft.  
 SCALE: 1 inch = 1,000 feet

PROJECT:  
**PROPOSED GATEWAY PACIFIC TERMINAL**

TITLE:  
**PROPOSED WETLAND MITIGATION AREAS**

DATE:  
FEBRUARY 2011

PROJECT NO.:  
091515338C-18-01

REV. NO.:  
1

FIGURE NO.:  
FIGURE 5-12





### 5.4.6 Proposed Compensation

The main goals for compensatory mitigation at the Terminal are as follows.

- Provide approximately 2 years advance compensation for 30.1 acres of direct impacts.
- Provide functional replacement for 12,814 linear feet of stream and drainage impacts.
- Increase the water quality functional capacity of the project area compared to current conditions, specifically with regard to stormwater treatment.
- Increase potential fish habitat in Streams 1 and 2 by improving connectivity and fish passage, increasing riparian functions, and installing habitat features.
- Protect and increase habitat functions for wetland-associated birds, mammals, and amphibians by developing structurally diverse native vegetation communities in created wetlands and riparian areas, by enhancing wetlands, and by providing protection to forested areas.
- Provide flood attenuation by diverting Stream 1 to an area containing created and enhanced wetlands during periods of high flow, and installing depressions within created riparian wetlands that would function to capture and retain water during periods of high flow.
- Use native vegetation to buffer the facility from adjacent habitats effectively and to provide habitat functions.

Table 5-17 provides a summary of on-site compensatory mitigation by construction stage. More details on how these objectives would be achieved are provided in the *Preliminary Conceptual Compensatory Mitigation Plan for the Proposed Gateway Pacific Terminal* (AMEC 2011).

#### 5.4.6.1 Net Compensatory Mitigation

The on-site mitigation proposed for the Gateway Pacific Terminal is shown on Figure 5-12. The adequacy of proposed mitigation for wetlands and stream impacts is evaluated based on meeting the minimum standard for offsets, replacement, or enhancement of wetland function and replacement or enhancement of wetland area.

#### Minimum Replacement Standard

The Gateway Pacific Terminal watershed would lose 140.6 acres of wetlands, while only 136 acres would be created, representing less than a 1:1 ratio for wetlands replacement area. This replacement alone would not meet the state and federal policy for no net loss of wetland acreage and function. While additional acreage would be enhanced (49 acres), this area would not provide the needed safety net (approximately 1–1.5 times the area) to cover the risk of compensation failure or temporal

**Table 5-17 Permanent Wetland Impacts and Proposed Mitigation**

Activity	Wetland Name <sup>1</sup>	Wetland type and rating category <sup>2</sup>	Permanent impact area by Cowardin class (acres)			Total permanent impact area (acres) <sup>3</sup>	Proposed mitigation type <sup>4</sup>	Wetland mitigation area (acres) <sup>5</sup>
			PSS	PFO	PEM			
Clearing, grading, excavation, filling for East Loop and Shared Services area. (See Mitigation Plan for details)	2	III	0.1	1.2	0.6	1.9	(C),(E)	Creation: Mitigation Areas A, B, G, H, I, J, K, L = 77.7 acres; Enhancement: Wetlands 2, 3, and 7A = 38.5 acres; Additional Compensation = 36 acre water quality pond; Total compensation area = 152.2 acres
	3	III	6.8	10.1	38.6	55.5	(C),(E)	
	4A	III	1.5	1.8	0.0	3.3	(C)	
	5A	III	2.9	2.0	2.1	7.0	(C)	
	5C	III	0.0	0.1	0.0	0.1	(C)	
	6	III	0.0	34.8	0.0	34.8	(C)	
	7A	III	0.3	1.2	0.0	1.5	(C),(E)	
	8B	III	0.0	0.0	0.1	0.1	(C)	
	9C	IV	0.0	0.0	0.1	0.1	(C)	
Parcel 14	N/A	0.0	5.1	0.0	5.1	(C)		
<b>Stage 1 Construction Total Impacts = 109.4 acres</b>								
Clearing, grading, excavation, filling for West Loop (See Mitigation Plan for details)	1	III	0.0	6.6	0.7	7.3	(C),(E)	Creation: Mitigation Areas C, D, E, F = 58.3 acres; Enhancement: Wetlands 1 and 9A = 10.4 acres; Total compensation area = 68.7 acres
	8A	III	7.3	4.6	3.2	15.1	(C)	
	9A	III	2.3	2.4	3.5	8.2	(C),(E)	
	10A	III	0.0	0.6	0.0	0.6	(C)	
<b>Stage 2 Construction Total Impacts = 31.2 acres</b>								

- 1 Assessment Units (AU) were given numerical designations and Wetlands were numbered by their AU and where more than one wetland was present, a letter was added.
- 2 Ecology wetland category based on current Western Washington Wetland Rating System.
- 3 Creation (C), Enhancement (E)
- 4 Preservation is proposed for 305 acres, including Wetland 12 (coastal lagoon).
- 5 All Mitigation Areas are anticipated to become Category II wetlands within 15 years after construction.

loss of wetland function that would occur. Preservation is highly merited, but does not in itself provide for lost area or functions of these systems and is in itself discounted heavily by Whatcom County. It is intended that the project will meet all requirements after further discussions with the pertinent agencies.

**Wetland and Stream Function**

Regulation and guidelines require that compensatory wetland mitigation provide equal or greater function than that lost through project impacts. These functions are measured in terms of water quality and hydraulic and habitat functions of wetlands. Functional evaluation of the proposed compensatory mitigation showed a functional lift at maturity (estimated to be 15 years after installation). In each

case, the functional score of the wetlands created is greater than the functional score of the wetlands lost, indicating a net gain in wetland function.

### **Wetland Area**

Direct mitigation of impacts to wetlands may occur by creating new wetlands or enhancing or preserving existing ones. Each of these strategies, however, does not yield the same degree of benefit towards achieving full mitigation of impacts. To account for the disparity in value of different mitigation methods, Whatcom County established the compensation ratios shown in Table 5-16.

One acre of mitigation is factored by a specific ratio to determine how much mitigation credit is awarded toward the goal of complete replacement of impacted area. According to Whatcom County Code requirements, it appears the total available acre-credits would be approximately 93.9 equivalent acres, which leaves a shortfall of approximately 46.7 equivalent acre-credits for the project to provide in some form other than on-site compensation. This calculation does not factor in any credit for stream realignments or creation of natural watercourses, or opening up 4,000 feet of stream habitat to fish, and providing other riparian functional improvements. Credits for these would restoration activities would be negotiated with agencies.

Pacific International Terminals is continuing land acquisition, planning, design, and implementation of alternative mitigation options to obtain the additional wetlands mitigation credits required for full mitigation of wetland and stream impacts.

## **5.5 ARCHAEOLOGICAL, CULTURAL, AND HISTORIC RESOURCES**

This section identifies and describes known cultural resources within the Gateway Pacific Terminal project area, evaluates potential impacts for the proposed project, and identifies design features to reduce those impacts. Site-specific archaeological information, as it pertains to this project, is presented in the *Gateway Pacific Terminal Archaeological Assessment Findings Report* (AMEC 2010). The evaluations and design features to reduce impacts presented in this section are based on evaluations of the impacts of the proposed project design on known resources in the project area.

The following key issue of concern was identified regarding cultural resources:

- Potential direct impacts to cultural resources and impacts to the integrity of setting, feeling, and association of cultural resource sites.

### 5.5.1 Affected Environment

Local agencies and regional Native American Tribes were contacted to obtain information about existing archaeological resources and traditional cultural places. This information is useful in characterizing and assessing the potential effects of the project. Additional information was also obtained from the following city and state agencies and other organizations regarding identified cultural resources in the Area of Potential Effects (APE):

- Washington State Department of Archaeology and Historic Preservation (DAHP) database, known as the Washington Information System for Architectural and Archaeological Records Data (WISAARD);
- National Register of Historic Places (NRHP);
- Washington State Historic Register (WSHR);
- Federally recognized Native American tribes: Lummi Nation and Nooksack Tribe;
- Whatcom County Historical Society;
- Whatcom County Tax Assessor's Office;
- Whatcom County Library: Ferndale Branch and Bellingham Branch;
- HistoryLink, an online encyclopedia of Whatcom County and Washington State history;
- University of Washington Suzzallo Library, Special Collections and Manuscripts;
- Western Washington University, Western Libraries; Center for Pacific Northwest Studies; and Anthropology Department (Sarah Campbell); and
- US Army Corps of Engineers-Seattle District, Cultural Resources Staff.

Information collected from the above sources helped to describe the existing cultural resource conditions in the project area and to identify the existing cultural resources in the APE. The APE for the proposed Gateway Pacific Terminal project was defined as the Pacific International Terminals property. Cultural resources on Parcel 14 (as shown on Figure 1-3) have not been evaluated as of February 2011.

Archaeological resources were investigated by conducting background research and conducting a field study consisting of on-the-ground field reconnaissance, pedestrian survey, and subsurface exploration. The background research carried out on DAHP's WISAARD database and at local libraries revealed that at least two previously documented archaeological sites (45WH1 and 45WH523) were present within the APE. The background research confirmed that the project area lies within lands and waters once occupied by several Puget Sound Tribes, whose descendents are

represented by federally recognized Indian Tribes including the Lummi Nation and Nooksack Tribe. Because of this, the APE is considered to have a high level of archaeological sensitivity.

Information that we evaluated for the *Gateway Pacific Terminal Archaeological Assessment Findings Report* (AMEC 2010) included:

- Previous cultural resource studies, including archaeological site records and cultural resources reports;
- Environmental background reports, including environmental histories and geological (geomorphological or geoarchaeological) analyses; and
- Ethnographic, ethnohistoric, and historic background material, including relevant ethnographic reports, local histories, newspaper articles, census data, city directories, historic photographs, historic aerial photographs, and historic maps,

Based on this background information, known and predicted sites with high, moderate, and low probability of containing pre-contact, ethnographic, and historic period archaeological resources were identified for the APE.

#### **5.5.1.1 Regulatory Context**

The term “cultural resources” encompasses historic properties, archaeological sites, Native American cultural resources, and other valued cultural resources. The National Historic Preservation Act (NHPA) became law in 1966 as a reflection of the importance of these resources to our national, regional, and local culture. Section 106 of the NHPA [United States Code (USC) Title 16, Section 470], as amended, and its implementing regulation [Code of Federal Regulations (CFR), Title 36, Part 800] provides for the establishment of the NRHP and the State Historic Preservation Officer/Office (SHPO), and directs federal agencies to consider the effect of their activities on historic properties.

The USACE-Seattle District is the lead federal agency for this undertaking. As a result, cultural resources studies for the project are subject to USACE-Seattle District procedures and review in consultation with the Washington State DAHP, and any federally recognized Native American Tribe that may have ancestral connections to the proposed APE. USACE-Seattle District Cultural Resources Staff is leading government-to-government consultation with the Lummi Nation and Nooksack Tribe. Properties of traditional religious and cultural importance to a Tribe according to Section 101(d)(6)(A) of the NHPA can be determined eligible for inclusion in the NRHP and thus be considered under NHPA.

Cultural resources must also be given consideration under the National Environmental Policy Act (NEPA), and Section 106 of the NHPA encourages maximum coordination with the NEPA process. Washington's State Environmental Policy Act (SEPA) closely resembles NEPA and requires environmental compliance at the state level. It requires that properties listed in or eligible for the WSHR be taken into account when undertakings enabled or funded by a state agency affect properties of historic, archaeological, scientific, or cultural importance (WAC 197 11-960). The Revised Code of Washington, Chapters 27.34, 27.44, and 27.53 protect Native American graves, archaeological sites, and cultural and historic resources from disturbance and give DAHP the authority to issue civil penalties for violations.

Under federal regulations, a project is considered to have an effect on a prehistoric or historic property when the undertaking could alter characteristics of the property that may qualify the property for inclusion in the NRHP. These alterations include alteration of location, setting, or use. An undertaking may be considered to have an adverse effect on a cultural property when the effect may diminish the integrity of the property's location, design, setting, materials, workmanship, feeling, or association.

Adverse effects on historic properties (per federal guidelines) include:

- Physical destruction or alteration of all or part of the property;
- Isolation of the property from or alteration of the property's setting when that character contributes to the property's qualifications for listing in the NRHP;
- Introduction of visual, audible, or atmospheric elements that are out of character with the property or that alter its setting;
- Neglect of a property resulting in its deterioration or destruction; and
- Transfer, lease, or sale of the property (36 CFR 800.9).

Section 106 of the NHPA requires that any federal agency having direct or indirect jurisdiction over a proposed federal or federally assisted undertaking, or issuing licenses or permits, must consider the effect of the proposed undertaking on historic properties. An historic site or property may include a prehistoric or historic district, site, building, structure, or object included in, or eligible for inclusion in, the NRHP. The US Secretary of the Interior maintains the NRHP. When evaluating resources, NRHP criteria for evaluation of significance of cultural resources properties must be applied.

According to the National Register Criteria for Evaluation:

*The quality of significance in American history, architecture, archaeology, engineering and culture is present in districts, sites, buildings, structures, and objects that possess integrity of location, design, setting, materials, workmanship, feeling, and association, and:*

- A. That are associated with events that have made a significant contribution to the broad patterns of our history; or
- B. That are associated with the lives of significant persons in our past; or
- C. That embody the distinctive characteristics of a type, period, or method of construction, or that represent the work of a master, or that possess high artistic values, or that represent a significant and distinguishable entity whose components may lack individual distinction; or
- D. That have yielded or may be likely to yield, information important in history or prehistory.

Historic significance is the importance of a property to a community, state, or the nation. In addition to the above criteria, significance is defined by the area of history in which the property made important contributions and by the period of time when these contributions were made (National Register Bulletin 16).

#### **5.5.1.2 Cultural Resources Investigations within the Area of Potential Effect**

Two phases of cultural resource investigations have been conducted within the Gateway Pacific Terminal APE. Northwest Archeological Associates (NWAA) reported results from an intensive archaeological survey of approximately 340 acres conducted in the western and southwestern portions of the Gateway Pacific Terminal property in the 1990s (Miss 1996). One pre-contact archaeological site (45WH523) and five historic-period structures-in-ruin<sup>1</sup> were documented during that investigation, in addition to the reconnoitering of the previously documented pre-contact and ethnographic site at Cherry Point (45WH1). NWAA concluded that the five historic-period sites were not eligible for listing in the NRHP because they lacked architectural integrity (Miss 1996:16). It was recommended that additional testing at site 45WH523 be made to determine if other associated material was to be found, and to determine if horizontal and vertical integrity were intact (Miss 1996:16). Site 45WH1, which has been the subject of numerous archaeological investigations (Grabert and Hall 1978; Blodgett 1976; Markham 1993; Donald 1995; Desilets 1995; Dugas 1996; Rorabaugh 2009; VanBuskirk 2000), has been determined eligible for the NRHP (Miss 1996).

---

<sup>1</sup> Note: Smithsonian Trinomial numbers were not assigned for these five resources.

The most recent phase of cultural resource surveys of the Gateway Pacific Terminal project area were conducted by AMEC between 2008 and 2010 (AMEC 2010). These efforts consisted of a background literature and records review, an intensive pedestrian survey and subsurface exploration of the unsurveyed portions of the APE, subsurface testing of 45WH523, and a boundary delineation of 45WH1. During the intensive pedestrian survey and subsurface exploration, 11 newly discovered archaeological sites and 2 isolated finds were recorded (Table 5-17). The newly discovered archaeological sites consist of early to mid-20th century farmstead foundations-in-ruin, historic refuse piles, and one pre-contact lithic scatter. Recorded isolated finds consist of individual pre-contact lithic artifacts in both instances. None of the newly recorded sites is recommended as being eligible for listing in the NRHP. Further discussion of locations and eligibility information of each of these sites is presented in Section 5.5.1.3. A discussion on the site boundary delineation of 45WH1 and the subsurface testing of 45WH523 is also presented in Section 5.5.1.3.

**Table 5-18 Archaeological Sites in or near the APE<sup>1</sup>**

Site/Isolate Number	Description	NRHP Eligibility
45WH1	Cherry Point Site; extensive shell midden and features	Eligible
45WH523	No cultural material	Not Eligible
45WH869	Historic foundation in ruin	Not Eligible
45WH870	Historic Refuse Pile	Not Eligible
45WH871	Concrete Well in Ruin	Not Eligible
45WH872	Historic Foundation in Ruin	Not Eligible
45WH873	Historic Foundation in Ruin	Not Eligible
45WH874	Historic Foundation in Ruin	Not Eligible
45WH875	Farmstead in Ruin	Not Eligible
45WH876	Historic Foundation in Ruin	Not Eligible
45WH877	Historic Foundation in Ruin	Not Eligible
45WH878	Historic Foundation in Ruin	Not Eligible
45WH879	Pre-contact lithic material	Not Eligible
45WH880	Pre-contact isolated find	Not Eligible
45WH881	Pre-contact isolated find	Not Eligible

Source: AMEC 2010.

**5.5.1.3 Documented Cultural Resources within the Area of Potential Effect**

Table 5-17 presents the documented archaeological resources within the APE. In addition to the 13 archaeological sites and 2 isolated finds, five additional historic-period sites were recorded by NWAA in 1996 and are not included in this table. Those sites that are eligible or potentially eligible as:



**Site 45WH1**

Multiple archaeological investigations since the mid-20th century have been conducted at Site 45WH1. AMEC (2010) conducted the most recent surveys with the goal of accurately delineating the boundaries of Site 45WH1 with a precision of less than 2 meters, so that designers could develop facility plans without threatening the integrity of this significant historic property. The initial investigation took place in October 2008, with subsequent site visits in 2009 and 2010. To determine the boundary, AMEC conducted close-interval sampling of the northern (inland) edge of the site using a small-diameter auger (AMEC 2010). This approach allowed direct mapping of the extent of the midden without damaging the archaeological deposits. The AMEC archaeologists also walked the beach checking for evidence of the midden that might have been visible in the bluff. They found midden deposits approximately 270 meters (885 feet) from the east end of the site. Global positioning system (GPS) coordinates of the beach and bluffs at the west end were taken. At the completion of the investigation, the boundaries of Site 45WH1 were accurately delineated (AMEC 2010).

**Site 45WH523**

Archaeological Site 45WH523 is located on an uplifted glaciomarine surface northwest from Site 45WH1. AMEC conducted archaeological testing of Site 45WH523 from April 19 to 23, 2010, with an additional day of excavation on June 2, 2010 (AMEC 2010). A total of 76 test units measuring 50 by 50 centimeters were excavated across the previously defined site boundary. No archaeological material was recovered from any of the test units. Angular rocks deposited as part of glaciomarine drift did occur in the test units. However, AMEC concluded that angular broken rocks that derive from this glaciomarine deposit were identified incorrectly as pre-contact lithic material by the previous archaeologists. Field archaeologists recovered no additional archaeological materials. Based on the absence of cultural materials, AMEC recommended removing 45WH523 from the Washington State Archaeological Database (AMEC 2010).

**Site 45WH879**

Site 45WH879 is a lithic assemblage consisting of two flakes, one core, and six pieces of fire-modified rock. The lithic assemblage associated with Site 45WH879 suggests that this site was possibly a short-term encampment. Site testing included excavating two 50- by 50-centimeter test units and one 1- by 1-meter test unit. Results from these test excavations found that soils containing the site were disturbed by grading associated with either the construction or demolition of various modern developments in the area (now only foundations-in-ruin) (AMEC 2010).

**Other Recorded Sites**

Five historic-period structures-in-ruin (circa 1960s) were recorded during the NWAA investigation in 1996 (Miss 1996). At that time, these structures-in-ruin were not old enough to be assigned Smithsonian archaeological site trinomials. These structures, comprised of only poured concrete

foundations, are consistent with the other historic structures-in-ruin encountered during AMEC's investigation of the project area in 2008–2010 (AMEC 2010). During the 1996 cultural resource investigation, NWAA determined that these five historic structures-in-ruin were not eligible for listing in the NRHP because they do not yield any significant information to the history of the area. AMEC similarly concluded that other historic structures-in-ruin are not eligible for listing (AMEC 2010) (Table 5-17).

### **5.5.2 Potential Effects on Archeological, Cultural, and Historic Resources**

Section 106 of the NHPA, as amended, requires federal agencies to take into account the effects of an undertaking on historic properties, defined as cultural resources that are listed in, or eligible for listing in, the NRHP. Site 45WH1 is an archaeological site that has significance both as an archaeological resource, and as a potential Traditional Cultural Property. Impacts to this site may result from the construction of the Gateway Terminal Project.

No direct impacts to Site 45WH1 are anticipated as the project has been designed to avoid impacts within the site boundaries. However, indirect impacts to Site 45WH1 could result in an adverse effect per Section 106 of the NHPA. Because Site 45WH1 is considered a potential Traditional Cultural Property, construction of the Terminal affects the integrity of setting, feeling, and association. And because indirect effects cannot be avoided, design features to lessen the effects of project impacts are presented below.

Compensatory wetland and stream restoration and enhancement could affect cultural resources located within the project area. Specifically the construction of one of the proposed wetland enhancement projects would be situated in and around Site 45WH879. This archaeological site was determined to be not eligible for listing in the NRHP; however, due to its location, it does have the potential to yield inadvertent discoveries and impacts to undocumented resources. It is likely that Site 45WH879 would be completely removed during the compensatory actions.

No other cultural resources located within the project area would be adversely affected by the proposed project.

### **5.5.3 Proposed Design Features Intended to Reduce Impacts**

Indirect impacts to Site 45WH1 associated with construction of the Terminal have the potential to be significant, and under existing plans are unavoidable. Pacific International Terminals will work with DAHP and the affected Native American Tribes (Lummi Nation and Nooksack Tribe) to develop a mitigation plan to address potential effects of the marine terminal development on the site. The mitigation plan would form the basis for a Memorandum of Agreement (MOA) between Pacific International Terminals, the USACE, the Washington SHPO, and the affected Native American Tribes.

To mitigate adverse effects to Site 45WH1, an archaeologist should be present during the construction of project elements located within 200 feet of the boundary of Site 45WH1. In addition, a professional archaeologist should be present during the construction of the compensatory wetland and stream restoration near Site 45WH879 as potential exists for inadvertent discoveries and impacts to undocumented resources (AMEC 2010).

The presence of an archaeologist would allow proper documentation of any cultural materials or features (e.g., shell midden, fire-cracked rock, or burned sediment) that may be uncovered inadvertently during the construction process. Prior to construction, an Inadvertent Discovery Plan should be prepared outlining the procedures that should be followed if archaeological materials are found during construction. If archaeological resources are discovered during the construction process and a monitor is not present, all work at that location should cease, and the Inadvertent Discovery Plan should be followed (AMEC 2010).

If cultural resources (e.g., artifacts such as stone tools, bottles, ceramics, bone, or shell) are discovered during the excavation work, all work in the vicinity should stop. The contractor should work with a professional archaeologist and the Washington State DAHP to evaluate the significance of the find (AMEC 2010). State statutes RCW 27.44.055, 68.60.055, and 68.50.645 require any individual discovering human remains to report them to county law enforcement and the Lummi Nation and Nooksack Tribe if the remains are determined to be Native American.

## **5.6 ROADWAY AND RAILROAD TRANSPORTATION**

This section describes the existing roadway and railroad network near the proposed Terminal, presents a summary of traffic volumes, and summarizes the effects of the proposed project on the existing roadway and railroad infrastructure. Road and rail traffic resulting from construction and operation of the Terminal could result in changes to the level of service (LOS) provided by existing road and railroad systems.

Key issues of concerns regarding potential transportation impacts of the Terminal include:

- Maintaining an LOS on affected roadways that meets state and county LOS standards;
- Conducting terminal operations in a manner that would not reduce availability or quality of rail services to other existing users of the BNSF Railway system.

### **5.6.1 Affected Environment**

This section describes the existing road and rail transportation networks in the project vicinity. To evaluate potential effects, the study area is defined generally as the area bounded by Birch Bay–

Lynden Road to the north, Interstate 5 (I-5) to the east, Slater Road to the south, and Blaine Road to the west. The boundaries of the transportation study area are shown in Figure 5-13.

### **5.6.1.1 Roadway Transportation**

Fifteen key intersections were identified in the transportation study area and are evaluated in this assessment. The intersection geometry at each of these locations is shown on Figure 5-13. These intersections serve as important throughpoints and access points to the road network in the area. Impacts to these traffic intersections could affect road and highway traffic. These 15 key intersections are listed below:

- Intersection #1: Aldergrove Road and Kickerville Road
- Intersection #2: Grandview Road and Kickerville Road
- Intersection #3: Grandview Road and Olson Road
- Intersection #4: Grandview Road and Portal Way
- Intersection #5: Bay Road and Kickerville Road
- Intersection #6: Arnie Road and Valley View Road
- Intersection #7: Grandview Road and Blaine Road
- Intersection #8: Birch Bay-Lynden Road and Blaine Road
- Intersection #9: Birch Bay-Lynden Road and Portal Way
- Intersection #10: Slater Road and Sunset Avenue/Rural Avenue
- Intersection #11: Slater Road and Lake Terrell Road
- Intersection #12: Rainbow Road/Mountain View Road and Lake Terrell Road
- Intersection #13: Rainbow Road/Henry Road and Kickerville Road
- Intersection #14: Main Street/West Axton Road and Riverside Drive/Labounty Drive
- Intersection #15: Slater Road and Haxton Way

### **Roadway Transportation Network and Conditions**

The roadway network in the project vicinity is predominantly rural and has lower than average traffic volumes. Most existing roadways have been constructed of bituminous asphalt material and are 24 feet wide or less. Traffic is controlled through unsignalized methods (i.e., stop signs and yield signs) at all of these intersections, except for four signalized intersections near the I-5 corridor.

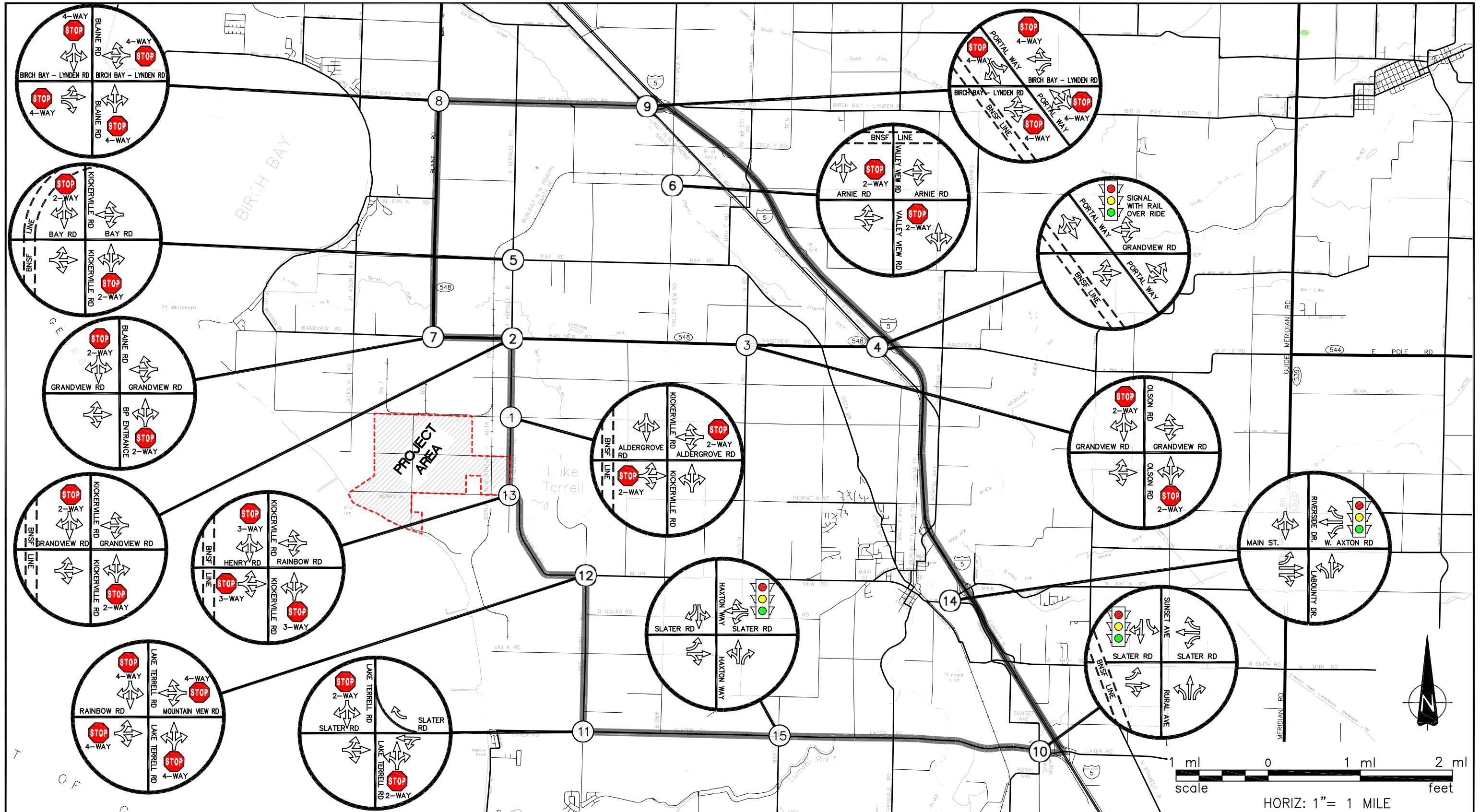

<b>LEGEND:</b> Study Area Boundary Analyzed Intersection Existing Stop-Controlled Intersection Existing Signalized Intersection	<b>CLIENT LOGO</b>  Pacific International Terminals <small>A Carris Enterprise</small>	<b>CLIENT:</b> PACIFIC INTERNATIONAL TERMINALS, INC.	<b>DWN BY:</b> BMM / MJR	<b>PROJECT</b> GATEWAY PACIFIC TERMINAL	<b>DATE:</b> JANUARY 2011
			<b>CHK'D BY:</b> BPL		<b>PROJECT NO.:</b> 5-91M-15338C-08-01
			<b>DATUM:</b> -	<b>TITLE</b> INTERSECTION GEOMETRY- INTERSECTIONS #1 TO #15	<b>REV. NO.:</b> -
			<b>PROJECTION:</b> -		<b>FIGURE No.</b> 5-13
			<b>SCALE:</b> AS SHOWN		



Whatcom County has established a hierarchy of streets based on four commonly accepted functional classifications:

- Principal arterials are streets that move large volumes of traffic between major traffic generators and destinations.
- Minor arterials are streets that move traffic from higher classification arterials to lesser arterials.
- Collector arterials are streets that move traffic from arterials to local access streets.
- Local streets move traffic from commercial, industrial, or residential areas to the collector arterials.

The existing arterial roadways serving the immediate project vicinity are:

- **Aldergrove Road** is a two-lane rural minor arterial running east/west. The lane width is 11 feet and the pavement is in average condition based on a visual inspection. The road has little or no shoulders and a posted speed limit of 35 miles per hour (mph) in the project vicinity. A signalized, at-grade rail crossing exists west of the intersection with Kickerville Road.
- **Grandview Road (SR 548)** is a two-lane, rural, principal arterial running east/west in the project vicinity between Cherry Point and I-5. The lane width varies between 11 and 12 feet and the pavement is in average condition, based on a visual inspection. The road has a combination of paved and gravel shoulders with a posted speed limit of 50 mph in the project vicinity.
- **Henry Road** is a local street running east/west with approximately 10-foot-wide lanes. The pavement is in average condition based on a visual inspection. The road does not have shoulders and has a posted speed limit of 35 mph in the project vicinity. A signalized, at-grade rail crossing exists west of the intersection with Kickerville Road.
- **Kickerville Road** is a two-lane, minor arterial running north/south with lane widths of 12 feet. The pavement condition is average based on a visual inspection. The road does not have shoulders and has a posted speed limit of 45 mph in the project vicinity.
- **Mountain View Road** is a two-lane, rural, principal arterial running east/west connecting Cherry Point with the City of Ferndale. The lane width is 12 feet and the pavement is in average condition based on a visual inspection. The road does not have shoulders and has a posted speed limit of 45 mph in the project vicinity.

## Existing Traffic Volumes

Industrial facilities and low-density residential areas characterize the traffic-generating land use in the vicinity. Therefore, peak traffic volumes reflect shift changes of major employers near Cherry Point.

Traffic counts were conducted at the previously referenced 15 intersections in the study area. Lower volume intersections were counted manually, while video recording systems were used at the higher volume intersections. The counts were conducted on Tuesday, June 22, and Wednesday, June 23, 2010.

The peak hour represents the four consecutive 15-minute periods with the highest total traffic volume for the intersection as a whole. In the study area, the PM peak hour volumes were higher than the AM peak hour volumes. Based on the results of the traffic count data, the PM peak hour was found to occur between 4:15 PM and 5:15 PM at a majority of the intersections; however, if the peak hour volume for a particular intersection occurred outside of that time frame, the actual peak hour volume was used in the LOS analysis.

The existing traffic operating conditions in the study area were analyzed using Trafficware's Synchro 7 traffic analysis software and the methodology in the *Highway Capacity Manual 2000* (Transportation Research Board 2000). The 2010 existing condition turning movement volumes are shown for Intersections 1–12 in Figure 5-14 and for Intersections 13–15 in Figure 5-15.

## Level of Service Standards

Level of service is a qualitative measure describing operational traffic conditions, and the perception of these conditions by drivers or passengers. These conditions include factors such as speed, delay, travel time, freedom to maneuver, traffic interruptions, comfort, convenience, and safety. Levels of service are given letter designations from A to F, with LOS A representing the best operating conditions (free flow, little delay) and LOS F, the worst (congestion, long delays). Generally, LOS A and B are considered high level of service, LOS C and D are considered moderate, and LOS E and F are considered low.

The Washington State Department of Transportation (WSDOT) has adopted standards for levels of service for highways of statewide significance. The Regional Transportation Planning Organization, in consultation with WSDOT, has adopted levels of service for other state highways. For state highways in Whatcom County, the standards are LOS D in urban areas and LOS C in rural areas. Similar to the LOS adopted on state highways, Whatcom County generally adopts LOS D in urban areas and LOS C in rural areas. LOS D has been adopted by Whatcom County for some of the rural roads that function as primary routes connecting major activity centers (as designated in the regional Whatcom Transportation Plan) to reflect higher peak-hour volumes (Whatcom County 2010).



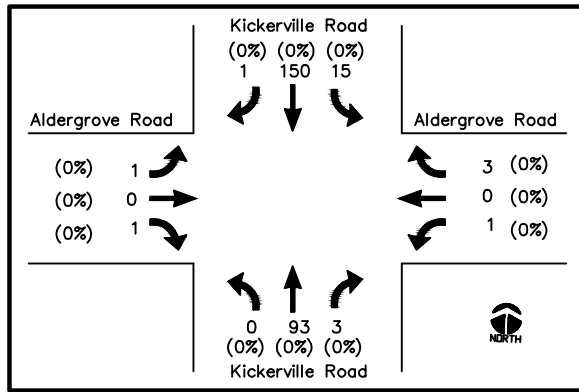

INTERSECTION NO. 1  
ALDERGROVE ROAD AND  
KICKERVILLE ROAD  
N.T.S.

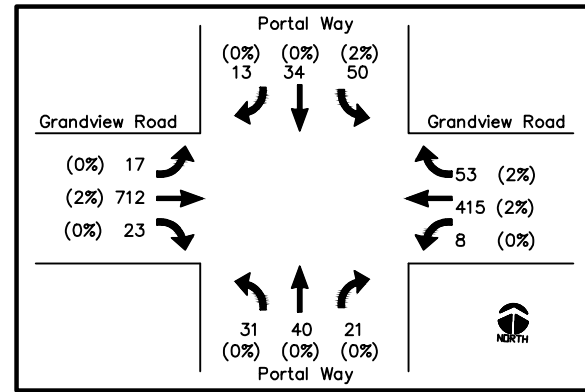

INTERSECTION NO. 4  
GRANDVIEW ROAD AND PORTAL WAY  
N.T.S.

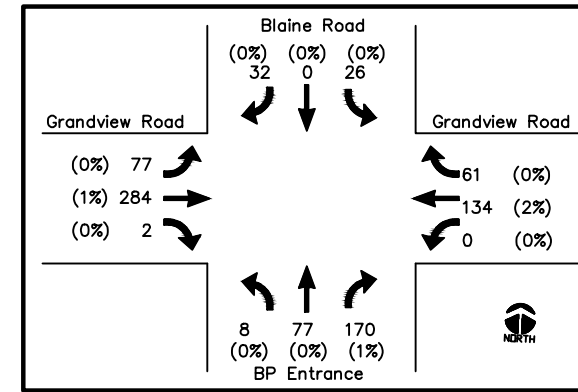

INTERSECTION NO. 7  
GRANDVIEW ROAD, BLAINE ROAD AND BP ENTRANCE  
N.T.S.

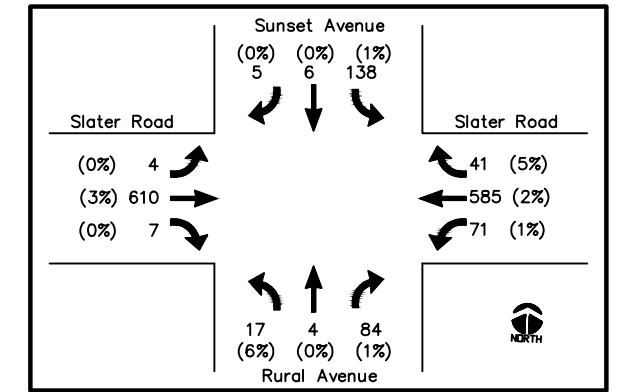

INTERSECTION NO. 10  
SLATER ROAD, RURAL AVENUE AND SUNSET AVENUE  
N.T.S.

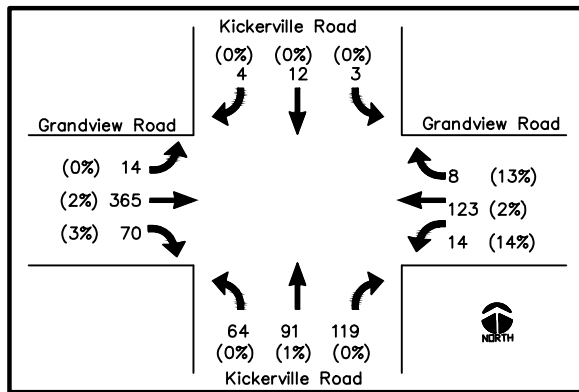

INTERSECTION NO. 2  
GRANDVIEW ROAD AND  
KICKERVILLE ROAD  
N.T.S.

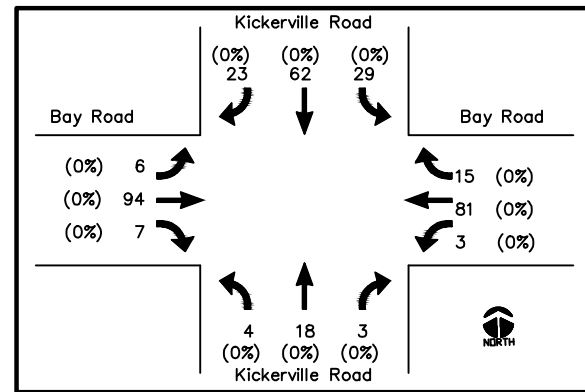

INTERSECTION NO. 5  
BAY ROAD AND KICKERVILLE ROAD  
N.T.S.

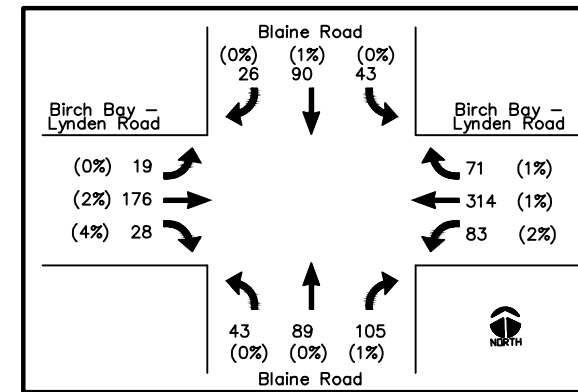

INTERSECTION NO. 8  
BIRCH BAY - LYNDEN ROAD AND BLAINE ROAD  
N.T.S.

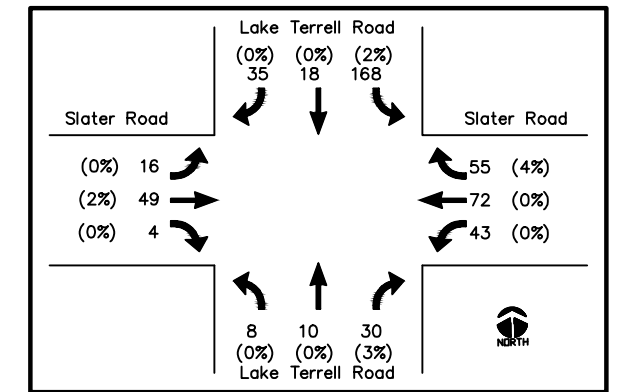

INTERSECTION NO. 11  
SLATER ROAD AND LAKE TERRELL ROAD  
N.T.S.

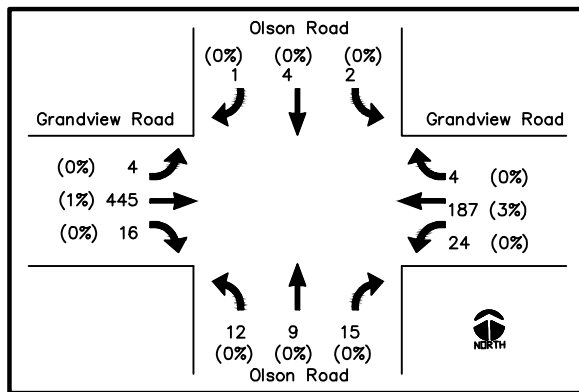

INTERSECTION NO. 3  
GRANDVIEW ROAD AND OLSON ROAD  
N.T.S.

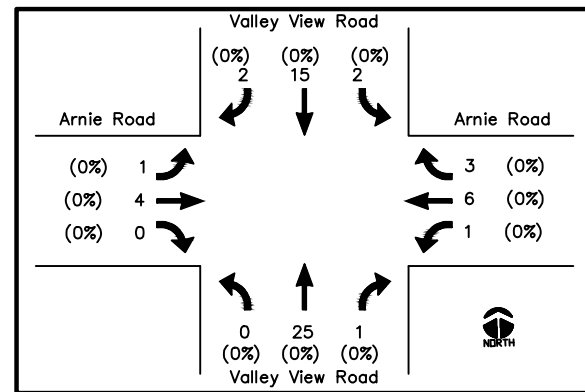

INTERSECTION NO. 6  
ARNIE ROAD AND VALLEY VIEW ROAD  
N.T.S.

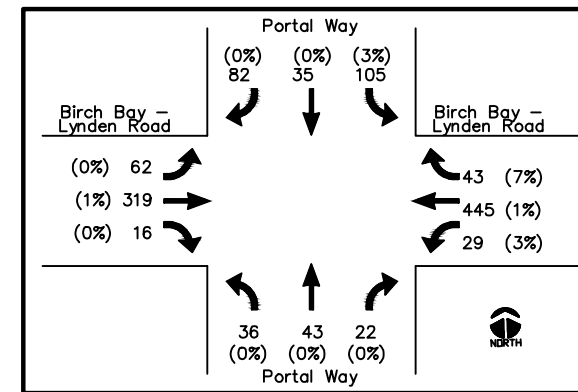

INTERSECTION NO. 9  
BIRCH BAY - LYNDEN ROAD AND PORTAL WAY  
N.T.S.

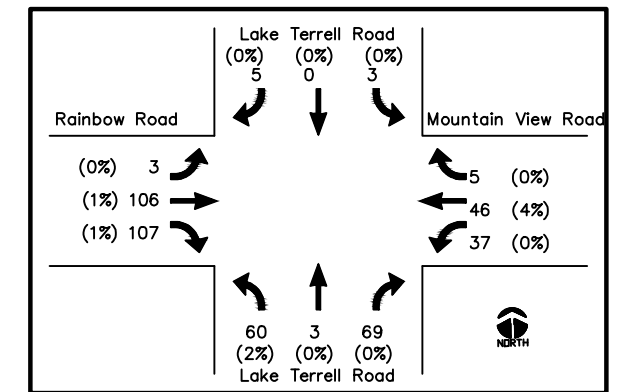

INTERSECTION NO. 12  
RAINBOW ROAD, MOUNTAIN VIEW ROAD AND  
LAKE TERRELL ROAD  
N.T.S.

**LEGEND:**

- Directional Indicators
- X PM Peak Hour Traffic Count
- (X%) Percent of Heavy Vehicles

CLIENT LOGO



Pacific International  
Terminals  
A Carrix Enterprise

CLIENT:

PACIFIC INTERNATIONAL TERMINALS, INC.

DWN BY:

BMM / MJR

CHK'D BY:

BPL

DATUM:

PROJECTION:

SCALE:

AS SHOWN

PROJECT

GATEWAY PACIFIC TERMINAL

TITLE

EXISTING VOLUMES 2010 ( PM) PEAK HOUR  
TURNING MOVEMENT VOLUMES  
INTERSECTIONS #1 TO #12

DATE:

JANUARY 2011

PROJECT NO:

5-91M-15338C-08-01

REV. NO.:

-

FIGURE No.

5-14



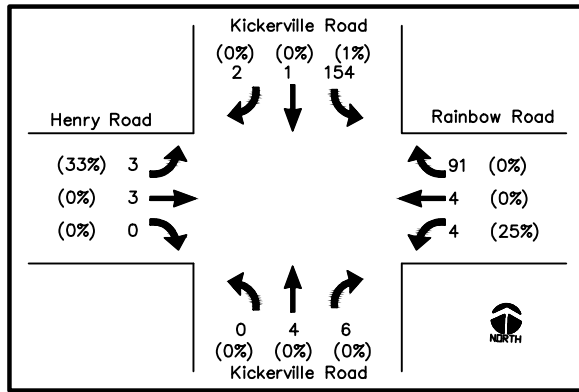

INTERSECTION NO. 13  
HENRY ROAD, RAINBOW ROAD AND KICKERVILLE ROAD  
N.T.S.

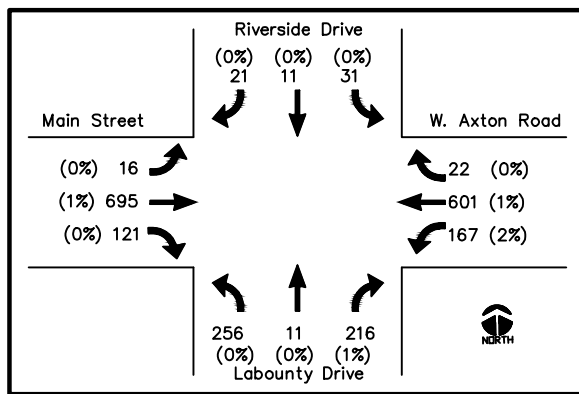

INTERSECTION NO. 14  
MAIN STREET, W. AXTON ROAD,  
RIVERSIDE DRIVE AND LABOUNTY DRIVE  
N.T.S.

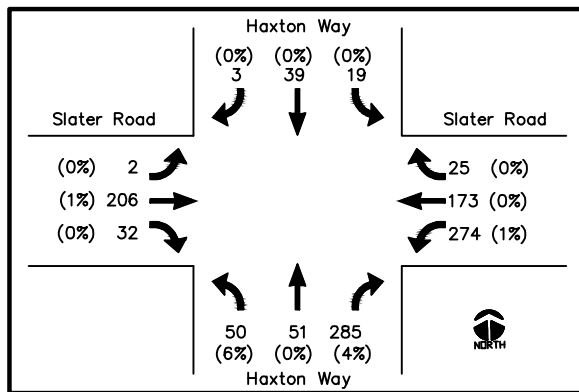

INTERSECTION NO. 15  
SLATER ROAD AND HAXTON WAY  
N.T.S.

**LEGEND:**

- Directional Indicators
- X PM Peak Hour Traffic Count
- (X%) Percent of Heavy Vehicles

CLIENT LOGO



CLIENT:

PACIFIC INTERNATIONAL TERMINALS, INC.

DWN BY: BMM / MJR  
CHK'D BY: BPL  
DATUM: -  
PROJECTION: -  
SCALE: AS SHOWN

PROJECT

GATEWAY PACIFIC TERMINAL

TITLE

EXISTING VOLUMES 2010 ( PM) PEAK HOUR  
TURNING MOVEMENT VOLUMES  
INTERSECTIONS #13 TO #15

DATE: JANUARY 2011

PROJECT NO:  
5-91M-15338C-08-01

REV. NO.: -

FIGURE No.  
5-15



**Table 5-19 2010 PM Peak Hour Level of Service, Delay, and Volume/Capacity (V/C) Ratio**

Intersection Number	Description	Volume (PM Peak Hour)	LOS	Avg. Delay (seconds)	V/C Ratio Actual <sup>1</sup>	V/C Ratio Limit <sup>2</sup>
1	Aldergrove Road and Kickerville Road	268	A	0.7	.01	.75
2	Grandview Road and Kickerville Road	887	B	8.8	.65	.75
3	Grandview Road and Olson Road	723	A	1.3	.10	.75
4	Grandview Road and Portal Way	1,307	B	15.7	.75 <sup>3</sup> - EB	.75
5	Bay Road and Kickerville Road	345	A	4.6	.17	.75
6	Arnie Road and Valley View Road	60	A	7.1	.03	.75
7	Grandview Road and Blaine Road	871	B	7.8	.52	.75
8	Birch Bay-Lynden Road and Blaine Road	1,087	C	22.0	1.00 <sup>3</sup> - WB	.90
9	Birch Bay-Lynden Road and Portal Way	1,237	E	38.8	1.00 <sup>3</sup> - WB	.90
10	Slater Road and Sunset Avenue/Rural Avenue	1,560	B	13.3	.71	.90
11	Slater Road and Lake Terrell Road	508	A	7.9	.37	.75
12	Rainbow Road/Mountain View Road and Lake Terrell Road	444	A	8.4	.28	.75
13	Rainbow Road/Henry Road and Kickerville Road	272	A	8.0	.21	.75
14	Main Street/West Axton Road and Riverside Drive/Labounty Drive	1,788	C	20.7	.72	.75
15	Slater Road and Haxton Way	1,099	A	7.3	.54	.75

1 EB = eastbound traffic; WB = westbound traffic.

2 Limit set by Whatcom County Comprehensive Plan (2010), Map #14A—Level of Service Standards Volume/Capacity Ratio.

3 Volume/capacity ratio of one of the approaches meets or exceeds the Whatcom County limit with existing traffic without the project improvements. Includes approach direction that fails.

In addition, Whatcom County established a limit on volume-to-capacity ratio of less than 0.75 during weekday PM peak hours for county arterials and collectors located outside of urban growth areas. The County identifies exceptions for specified primary routes, which shall have a volume-to-capacity ratio less than or equal to 0.90 (LOS D) (Whatcom County 2010). Table 5-18 shows the 2010 PM peak hour LOS, average delay time, actual volume/capacity (V/C) ratio, and Whatcom County V/C ratio limit for the 15 key intersections in the Gateway Pacific Terminal transportation study area.

### Traffic Safety

Whatcom County accident data for project area intersections is summarized in Table 5-19.

The existing collision rate for Whatcom County is 1.92 according to the 2009 WSDOT Collision data Summary. For rural principal arterials in the Northwest Region, the collision rate is 0.95. Based on the collision rates calculated, it appears that the intersections studied have no significant collision issues.

**Table 5-20 Collision Rate and Frequency – January 1, 2007 to December 31, 2010**

Intersection Number	Description	4-Year Total	Collision Frequency <sup>1</sup>	ADT <sup>2</sup>	Rate (per MVM) <sup>3</sup>
1	Aldergrove Road and Kickerville Road	1	0.25	2,680	0.26
2	Grandview Road and Kickerville Road <sup>4</sup>	—	—	8,870	—
3	Grandview Road and Olson Road <sup>4</sup>	—	—	7,230	—
4	Grandview Road and Portal Way <sup>4</sup>	—	—	14,170	—
5	Bay Road and Kickerville Road	4	1.00	3,450	0.79
6	Arnie Road and Valley View Road	0	N/A	600	N/A
7	Grandview Road and Blaine Road <sup>4</sup>	—	—	8,710	—
8	Birch Bay-Lynden Road and Blaine Road <sup>4</sup>	—	—	10,870	—
9	Birch Bay-Lynden Road and Portal Way	6	1.50	12,370	0.33
10	Slater Road and Sunset Avenue/Rural Avenue <sup>5</sup>	—	—	15,720	—
11	Slater Road and Lake Terrell Road	1	0.25	5,080	0.13
12	Rainbow Road/Mountain View Road and Lake Terrell Road	1*	0.25	4,440	0.15
13	Rainbow Road/Henry Road and Kickerville Road	1	0.25	2,720	0.25
14	Main Street/West Axton Road and Riverside Drive/Labounty Drive <sup>5</sup>	—	—	21,680	—
15	Slater Road and Haxton Way	9	2.25	11,590	0.53

1. Collision frequency is the number of collisions divided by traffic volume, expressed in collisions per million entering vehicles for intersections and collisions per 100 million vehicle-miles for street sections.
  2. ADT = Average delay trips. Estimated from peak hour volumes using a “k value” of 0.10 for rural/urban mixed area.
  3. MVM = number of accidents per millions of vehicle miles.
  4. Collision data requested from WSDOT were not available at the time of publication.
  5. Collision data requested from the City of Ferndale were not available at the time of publication.
- \* Fatal collision.

**Transit**

The Whatcom Transportation Authority (WTA) provides transit service near the project area. The nearest service is Route 55, which runs from Cordata Station to Blaine along Portal Way and Birch Bay-Lynden Road. No direct access to transit service is available closer to the project area.

**Non-motorized Facilities**

Few sidewalks and pedestrian crossings occur in the study area. Most of the area has rural arterial streets, where pedestrian movements are not encouraged. Surrounding streets have no marked bicycle lanes, and few bicycle movements were observed during 2010 traffic studies.

### **5.6.1.2 Rail Transportation**

Both freight and passenger rail services are provided in the project study area. The rail line serving the Terminal would be the BNSF Railway Custer Spur (Cherry Point Line), which connects to the BNSF Railway Bellingham Subdivision main line. The Custer Spur currently provides only freight cargo service, while the Bellingham Subdivision main line serves both freight cargo and passenger trains. Passenger rail currently serves the area, with the trains running along the Bellingham Subdivision main line.

The Custer Spur has at-grade crossings in the study area. The at-grade rail crossing locations are shown in Figure 5-16. The nearest road intersections to the Custer Spur at-grade crossings are intersections 1, 2, 5, 6, and 13. The at-grade crossings near intersections 1, 2, and 13 consist of actuated signals and gates. The crossings near intersections 5 and 6 are stop controlled. The Bellingham main line has at-grade crossings in the study area near intersections 4, 9, and 10. The signalized controls at Intersection 4 are pre-empted by the rail line (the traffic signal is overridden when rail traffic is present). Intersection 9 is stop controlled, and intersection 10 is signalized, but the rail line is far enough away from the intersection that there is no traffic signal pre-emption.

The intermediate pavement structures between the rails consist of asphalt pavement and/or wood timbers. The condition of the rail network is good, but some upgrades would be required to serve the Terminal, as described in Section 4.3.5.

Using the estimates of current railroad traffic provided by BNSF Railway and the assumption that the railroad crossing gates and warnings take 20 seconds to lower and 10 seconds to raise, it was determined that during the PM peak hour, current train operations on the Custer Spur result in an estimated delay of at most 6 minutes for road traffic at each of the at-grade rail crossings located near intersections 1, 2, 5, 6, and 13. The 6 minutes of delay would occur for a driver who arrives just as the train approaches. Although the actual delay at each intersection varies, this 6-minute delay time was developed and used as an estimate for all of the intersections for analysis purposes. Based on the railroad traffic frequency data provided by BNSF Railway, a blockage by freight train is estimated to occur one time daily during the PM peak hour at each location.

For freight traffic on the Bellingham Subdivision main line, it was determined that during the PM peak hour a maximum delay of 2 minutes is experienced at intersections 9 and 10 could be expected for a driver who arrives as the train approaches. Intersection 4 was analyzed using this same delay time. The actual delay at each intersection would vary; the delay times at Intersections 9 and 10 were used for other intersections as an estimate for analysis purposes. Based on the railroad traffic frequency data provided by BNSF Railway, a blockage by freight train is estimated to occur three times daily during the PM peak hour at each location.

Passenger trains would cause 1 minute of delay during the PM peak hour at intersections 4, 9, and 10. The actual delay at each intersection would vary; this value is used as an estimate for analysis purposes. Based on the railroad traffic frequency data provided by BNSF Railway, a blockage by a passenger train is estimated to occur on average one time during the PM peak hour at each location.

actual train arrival times are unpredictable and would vary daily, the analysis presented here is based on the assumption that vehicular traffic arrives at a consistent rate at the intersection in each approach. This assumption allows a reasonable estimate to be made of the number of vehicles affected by train blockage.

he turning movements and volume that cross the at-grade crossing during the entire PM peak hour period were analyzed for each intersection based on the total traffic volume during the peak hour, in directions affected by train blockage. The estimated minutes of delay are based on the assumption that vehicles arrive at a uniform rate for each movement.

Delay for each intersection was evaluated against the delay criteria provided in the *Highway Capacity Manual* (Table 5-20) to determine the LOS.

**Table 5-21 Level of Service Criteria for Two-Way Stop-Controlled Intersections**

Level of Service	Average Control Delay (sec/veh)
A	0 – 10
B	> 10 – 15
C	> 15 – 25
D	> 25 – 35
E	> 35 – 50
F	> 50

From Source: Exhibit 17-2, Transportation Research Board, *Highway Capacity Manual*, 2000.

The LOS rating was calculated for each intersection, with the estimated delay due to current train crossings, as presented above, taken into account. Each intersection was treated as a two-way, stop-controlled (TWSC) intersection due to the at-grade rail crossing. Table 5-21 shows a summary of the intersection delay and LOS before and after the delay due to train crossings is accounted for. The intersection LOS is a measure of how the intersection functions as a whole. Each separate approach has its own LOS, which may be higher or lower than the intersection LOS.



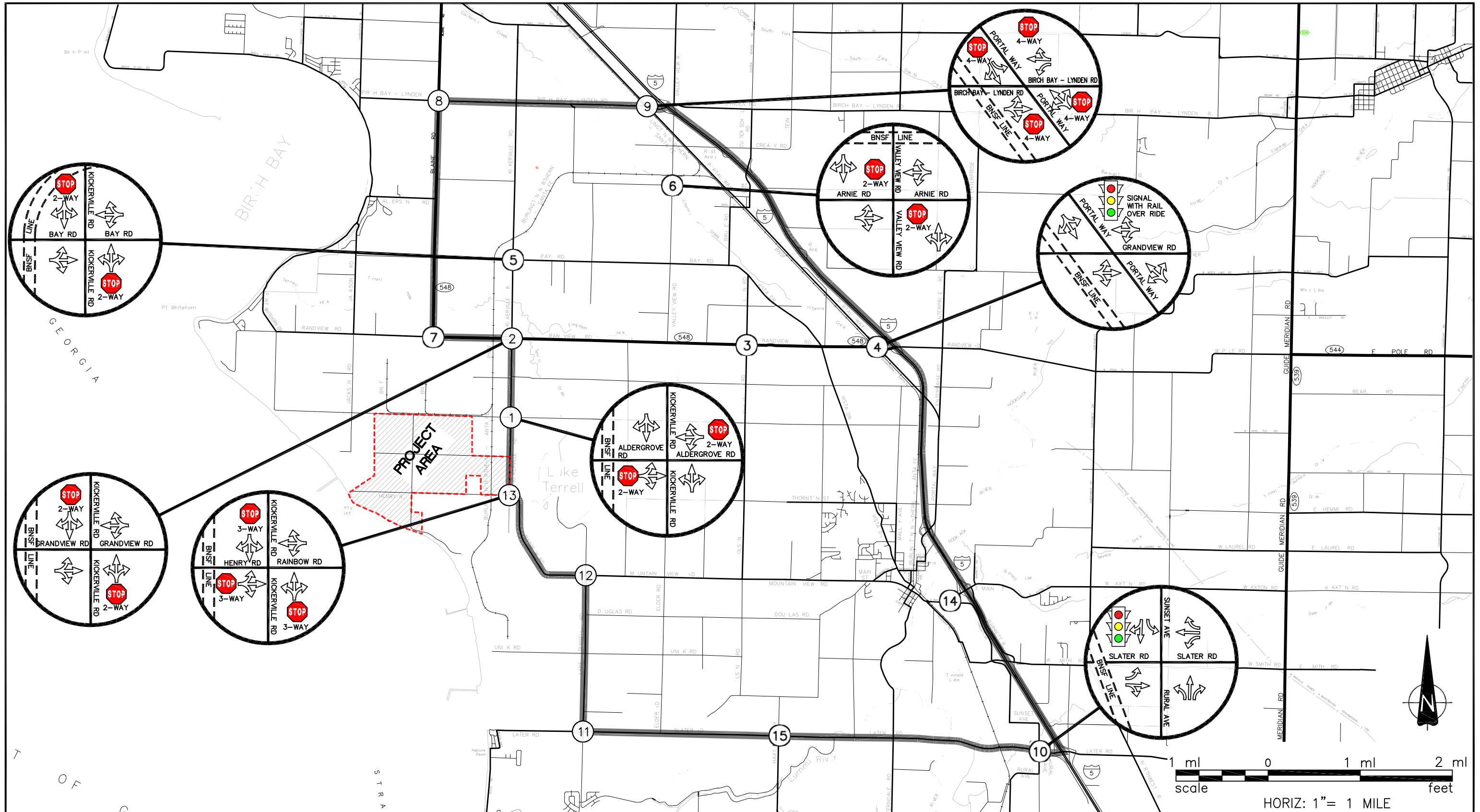

<b>LEGEND:</b> Study Area Boundary Analyzed Intersection Existing Stop-Controlled Intersection Existing Signalized Intersection	<b>CLIENT LOGO</b>  Pacific International Terminals <small>A Carris Enterprise</small>	<b>CLIENT:</b> PACIFIC INTERNATIONAL TERMINALS, INC.	<b>DWN BY:</b> BMM / MJR	<b>PROJECT</b> GATEWAY PACIFIC TERMINAL	<b>DATE:</b> JANUARY 2011
			<b>CHK'D BY:</b> BPL		<b>TITLE</b> AT-GRADE RAIL CROSSINGS
			<b>DATUM:</b> -		<b>REV. NO.:</b> -
			<b>PROJECTION:</b> -		<b>FIGURE No.</b> 5-16
			<b>SCALE:</b> AS SHOWN		



**Table 5-22 2010 PM Peak Hour Level of Service and Delay Without and With Train Crossings**

<b>Intersection Number</b>	<b>Description</b>	<b>Volume (PM Peak Hour)</b>	<b>LOS Without Trains</b>	<b>Average Delay (seconds)</b>	<b>LOS With Trains</b>	<b>Avg. Delay (seconds)</b>
1	Aldergrove Road and Kickerville Road	268	A	0.7	A	N/A
2	Grandview Road and Kickerville Road	887	B	8.8	C	23.2
4	Grandview Road and Portal Way	1,307	B	15.7	C	20.9
5	Bay Road and Kickerville Road	345	A	4.6	C	25.0
6	Arnie Road and Valley View Road	60	A	7.1	C	15.3
9	Birch Bay-Lynden Road and Portal Way	1,237	E	38.8	E	41.7
10	Slater Road and Sunset Avenue/Rural Avenue	1,560	B	13.3	C	18.2
13	Rainbow Road/Henry Road and Kickerville Road	272	A	8.0	A	N/A

As shown in Table 5-22, when factoring in the possible delay due to a train crossing during the PM peak hour, some intersections may operate at a lower LOS lower than they would in the absence of rail traffic. It should be noted that trains do not necessary impact the PM peak hour every day, and the durations may be different from day to day. The information presented in this analysis is an estimate of current typical rail operating conditions and their impacts to vehicular traffic.

## **5.6.2 Potential Effects**

The potential effects of the proposed project on transportation are evaluated in this section.

### **5.6.2.1 Roadway Transportation Effects during Construction**

Traffic volumes attributed to project construction include construction worker vehicles and construction vehicles typically associated with construction of a Terminal. These impacts would be short term, occurring only during terminal construction. Construction would occur in two stages. The duration of construction is anticipated to be 2 years for each stage.

Pacific International Terminals would work with Whatcom County and WSDOT during the permit process to identify and minimize impacts to existing traffic patterns, including potential roadway closures or lane reductions. Any access interruptions to occupied parcels during construction would be coordinated with the affected businesses or homeowners to minimize impacts.

### **5.6.2.2 Roadway Transportation Effects during Operation**

#### **Background Growth**

Historical traffic counts indicate an average annual growth rate of 2 percent per year in the project vicinity. The Terminal is anticipated to be developed in four operational phases, with Phase 1 generating traffic beginning in 2016. Phase 4 traffic rates would commence in 2026. Section 4.4 provides additional details regarding planned terminal development staging.

Existing PM peak period traffic counts were factored by 2 percent per year to estimate future year 2026 traffic volumes without Terminal development. Figures 5-17 and 5-18 show the turning movement volumes without the project-generated trips for the 2026 condition.

#### **Trip Generation—Employees**

Trip generation equations compiled by the Institute of Transportation Engineers (ITE) were used to compute the daily project-related traffic that would be generated by the Terminal (ITE 2008). Two published trip-generation rates for ITE land use code Waterport/Marine Terminal (010) were used to evaluate the potential number of trips that would be generated by the Gateway Pacific Terminal.

Based upon trip rates per acre, an estimated 6,017 daily trips would be generated. Based upon trip rates per berth, an estimated 479 daily trips would be generated. Characteristics of the proposed Terminal suggest that the specific characteristics for this project would be better represented by estimates based on trip rates per ship berth. Trip-generation estimates based on the anticipated number of employees (213 employees at 2.25 trips per day) yield approximately 480 daily trips. Additionally, total commodity throughput is limited by the total number of ship berths, not by the acreage of the project area, making the trip-generation rate based on ship berths more realistic.

The facility would be operational 24 hours per day. The proposed employee needs are divided into three shifts: 7 AM to 4 PM, 3 PM to 12 AM, and 11 PM to 8 AM. The day shift (7 AM to 4 PM) during Operational Phase 4 would require 88 employees. It is estimated that each employee would generate 2.25 trips per day. This represents one trip to and from work, and 1 out of 4 employees leaving for lunch or another errand during their shift. For this shift of 88 employees, it is estimated they would generate 198 trips per day.

For the purpose of the analysis, it is assumed that 100 percent of the day-shift employees would leave the Terminal from 4:15 to 5:15 PM (during the peak hour). This is a conservative estimate, as some employees would leave before 4:15 PM when their shift ends. The result is that the estimated number of PM peak hour trips would be 88 trips (home from work) for this shift.

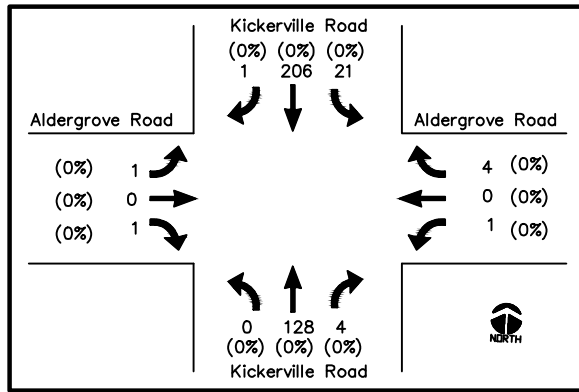

INTERSECTION NO. 1  
ALDERGROVE ROAD AND  
KICKERVILLE ROAD  
N.T.S.

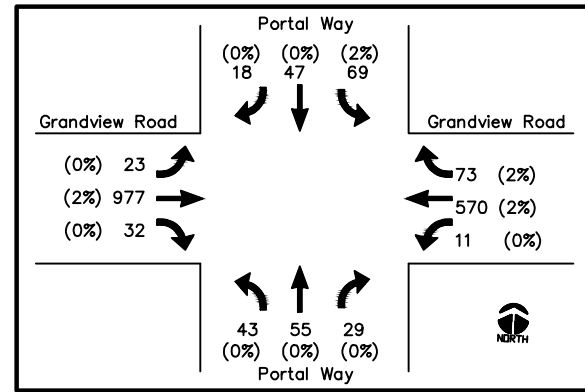

INTERSECTION NO. 4  
GRANDVIEW ROAD AND PORTAL WAY  
N.T.S.

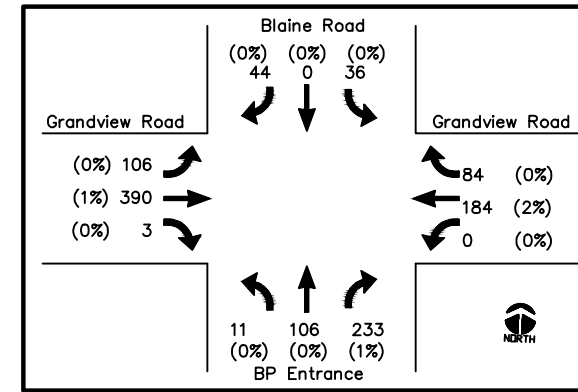

INTERSECTION NO. 7  
GRANDVIEW ROAD, BLAINE ROAD AND BP ENTRANCE  
N.T.S.

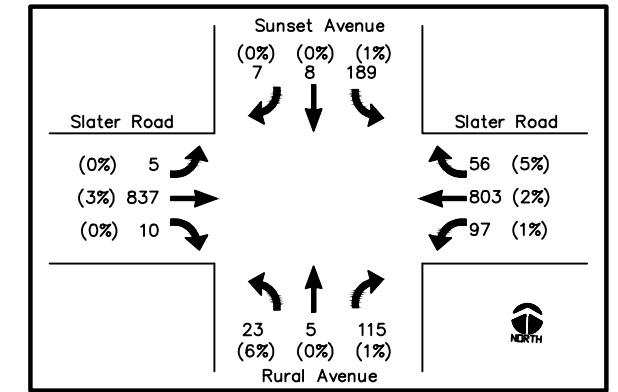

INTERSECTION NO. 10  
SLATER ROAD, RURAL AVENUE AND SUNSET AVENUE  
N.T.S.

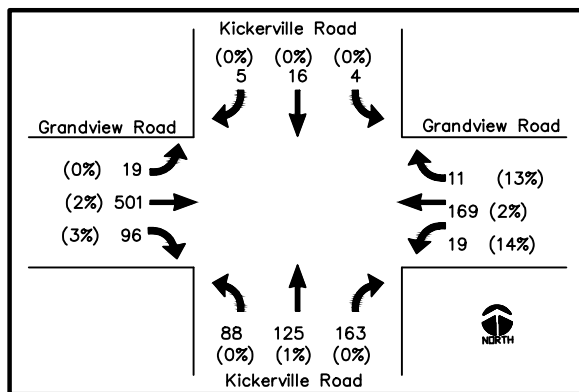

INTERSECTION NO. 2  
GRANDVIEW ROAD AND  
KICKERVILLE ROAD  
N.T.S.

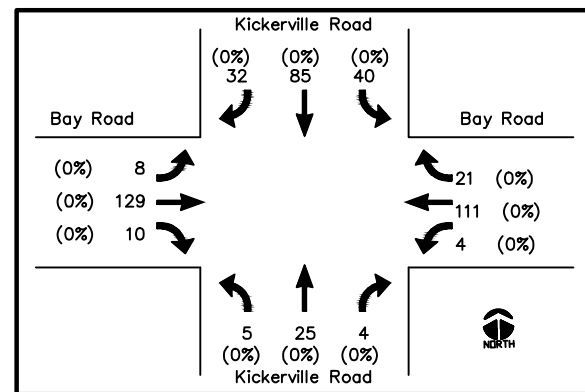

INTERSECTION NO. 5  
BAY ROAD AND KICKERVILLE ROAD  
N.T.S.

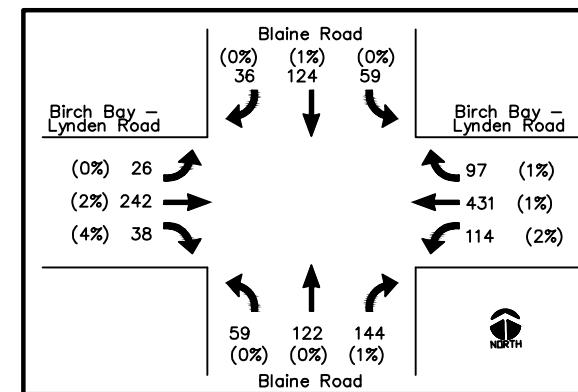

INTERSECTION NO. 8  
BIRCH BAY - LYNDEN ROAD AND BLAINE ROAD  
N.T.S.

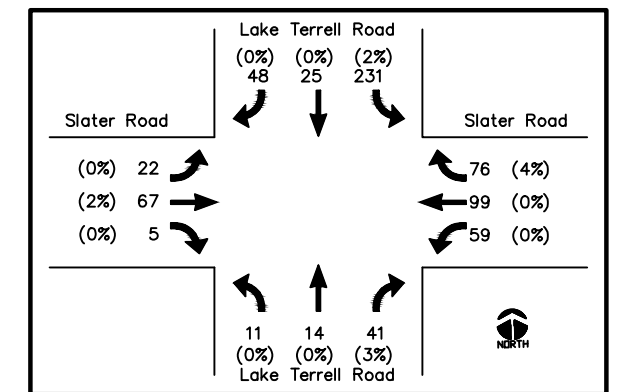

INTERSECTION NO. 11  
SLATER ROAD AND LAKE TERRELL ROAD  
N.T.S.

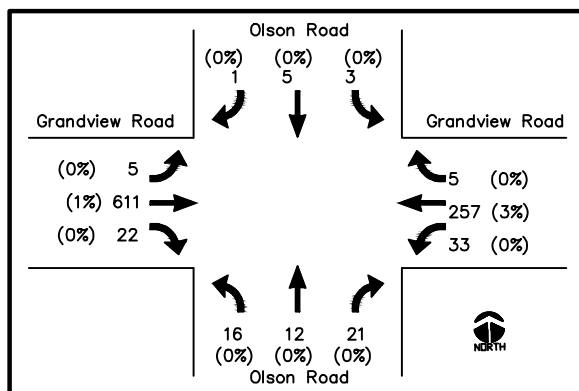

INTERSECTION NO. 3  
GRANDVIEW ROAD AND OLSON ROAD  
N.T.S.

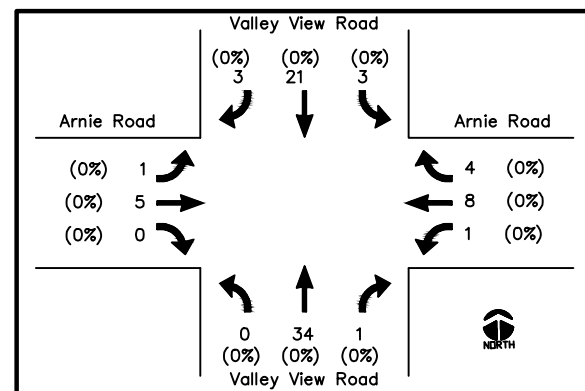

INTERSECTION NO. 6  
ARNIE ROAD AND VALLEY VIEW ROAD  
N.T.S.

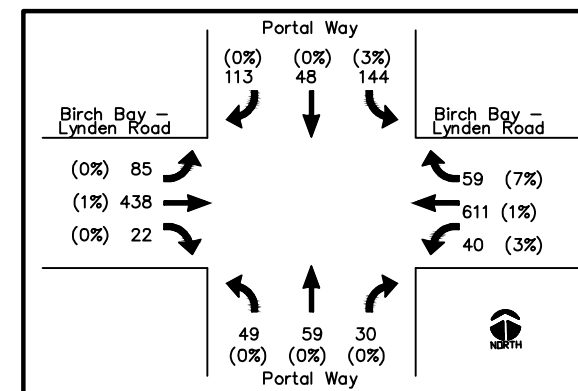

INTERSECTION NO. 9  
BIRCH BAY - LYNDEN ROAD AND PORTAL WAY  
N.T.S.

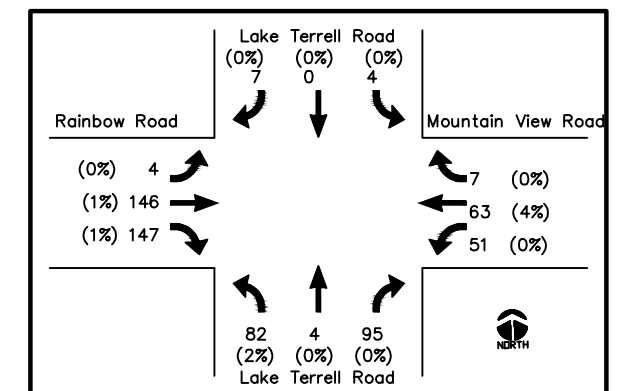

INTERSECTION NO. 12  
RAINBOW ROAD, MOUNTAIN VIEW ROAD AND  
LAKE TERRELL ROAD  
N.T.S.

**LEGEND:**

- Directional Indicators
- X PM Peak Hour Traffic Count
- (X%) Percent of Heavy Vehicles

CLIENT LOGO



Pacific International  
Terminals  
A Carrix Enterprise

CLIENT:

PACIFIC INTERNATIONAL TERMINALS, INC.

DWN BY:

BMM / MJR

CHK'D BY:

BPL

DATUM:

-

PROJECTION:

-

SCALE:

AS SHOWN

PROJECT

GATEWAY PACIFIC TERMINAL

TITLE

FUTURE VOLUMES 2026 ( PM) PEAK HOUR  
WITHOUT PROJECT  
INTERSECTIONS #1 TO #12

DATE:

JANUARY 2011

PROJECT NO:

5-91M-15338C-08-01

REV. NO.:

-

FIGURE No.

-

FIGURE No.

5-17

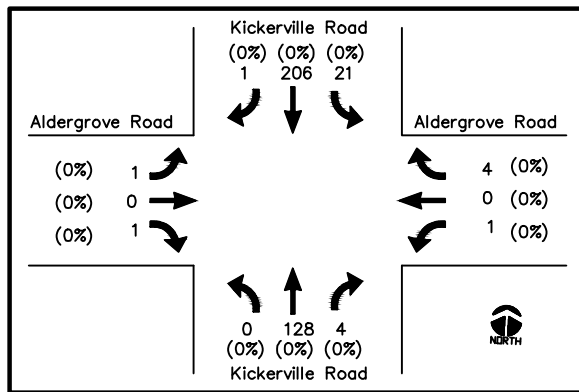

INTERSECTION NO. 1  
ALDERGROVE ROAD AND  
KICKERVILLE ROAD  
N.T.S.

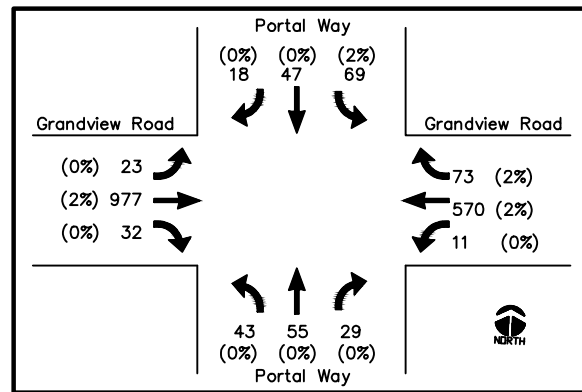

INTERSECTION NO. 4  
GRANDVIEW ROAD AND PORTAL WAY  
N.T.S.

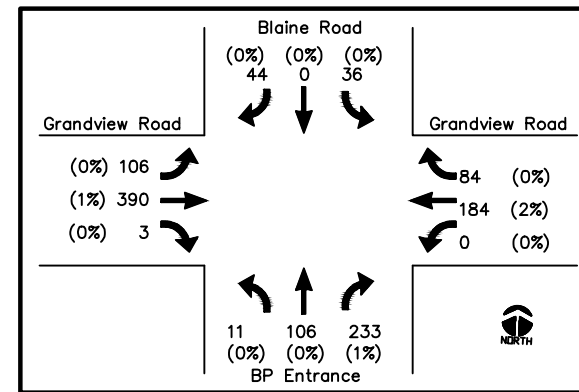

INTERSECTION NO. 7  
GRANDVIEW ROAD, BLAINE ROAD AND BP ENTRANCE  
N.T.S.

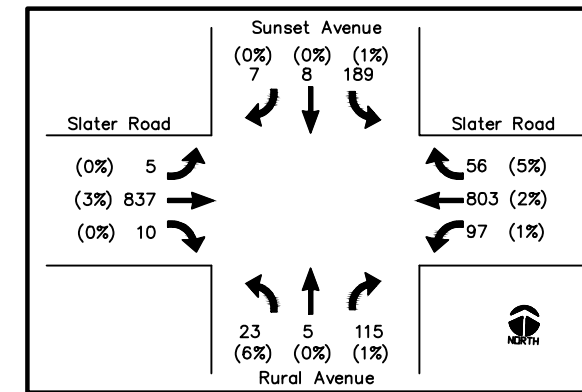

INTERSECTION NO. 10  
SLATER ROAD, RURAL AVENUE AND SUNSET AVENUE  
N.T.S.

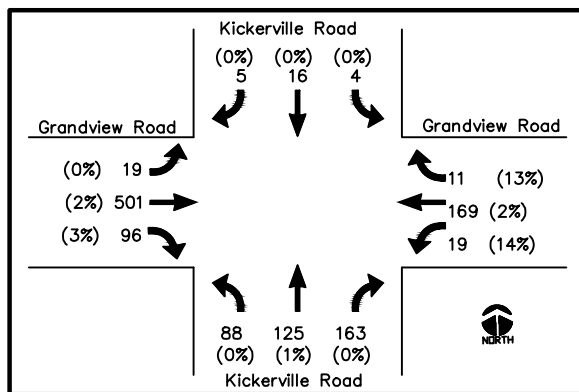

INTERSECTION NO. 2  
GRANDVIEW ROAD AND  
KICKERVILLE ROAD  
N.T.S.

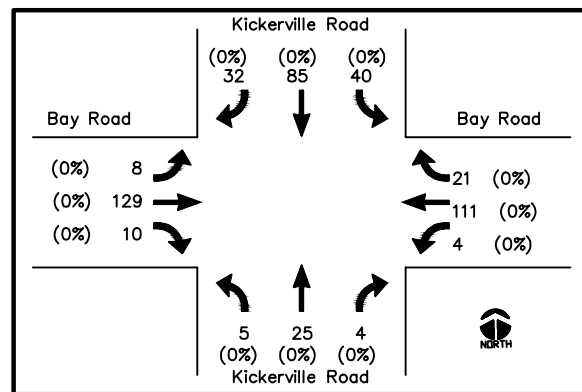

INTERSECTION NO. 5  
BAY ROAD AND KICKERVILLE ROAD  
N.T.S.

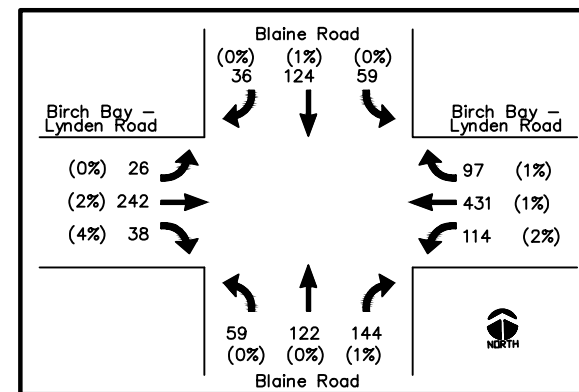

INTERSECTION NO. 8  
BIRCH BAY - LYNDEN ROAD AND BLAINE ROAD  
N.T.S.

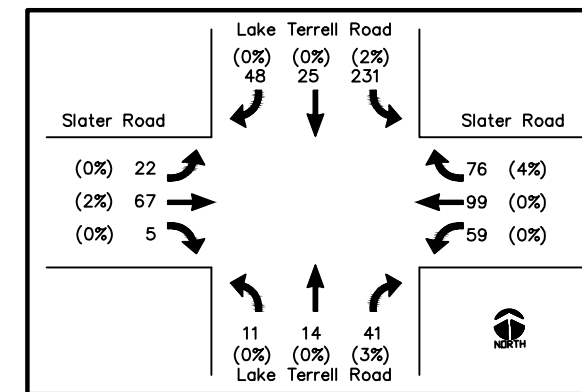

INTERSECTION NO. 11  
SLATER ROAD AND LAKE TERRELL ROAD  
N.T.S.

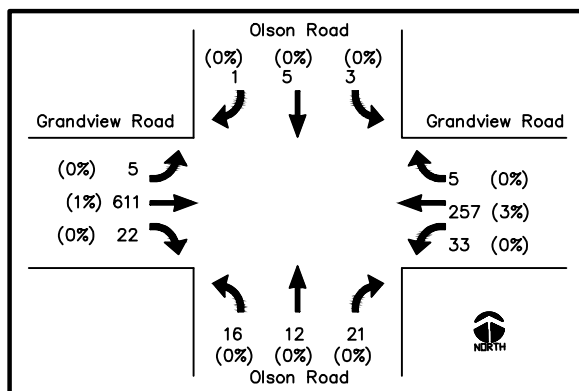

INTERSECTION NO. 3  
GRANDVIEW ROAD AND OLSON ROAD  
N.T.S.

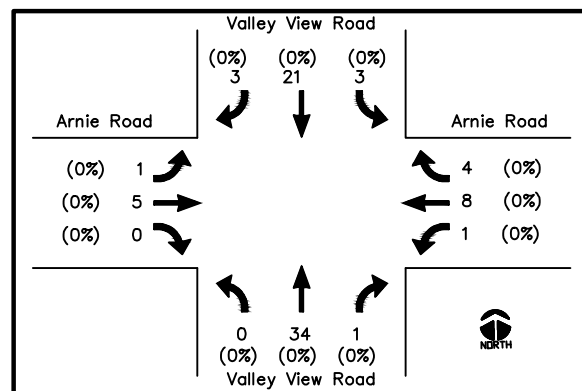

INTERSECTION NO. 6  
ARNIE ROAD AND VALLEY VIEW ROAD  
N.T.S.

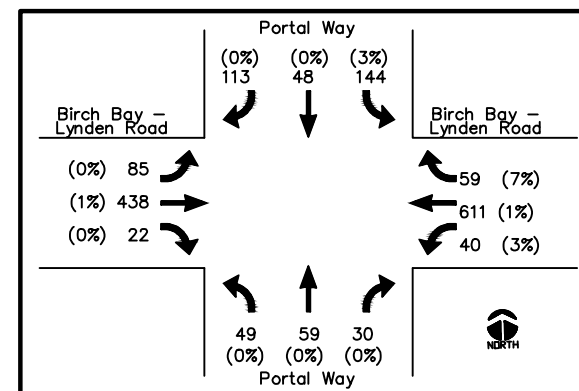

INTERSECTION NO. 9  
BIRCH BAY - LYNDEN ROAD AND PORTAL WAY  
N.T.S.

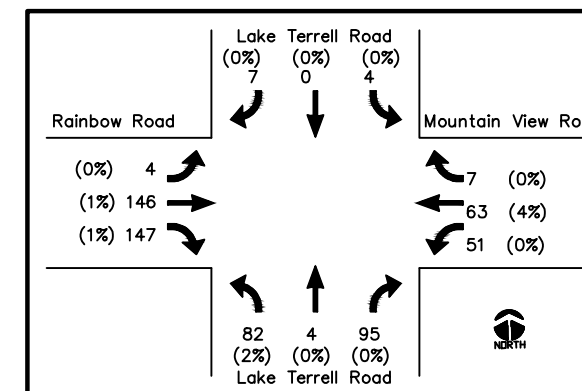

INTERSECTION NO. 12  
RAINBOW ROAD, MOUNTAIN VIEW ROAD AND  
LAKE TERRELL ROAD  
N.T.S.

**LEGEND:**

- Directional Indicators
- X PM Peak Hour Traffic Count
- (X%) Percent of Heavy Vehicles

CLIENT LOGO



Pacific International  
Terminals  
A Carrix Enterprise

CLIENT:

PACIFIC INTERNATIONAL TERMINALS, INC.

DWN BY:

BMM / MJR

CHK'D BY:

BPL

DATUM:

PROJECTION:

SCALE:

AS SHOWN

PROJECT

GATEWAY PACIFIC TERMINAL

TITLE

FUTURE VOLUMES 2026 ( PM) PEAK HOUR  
WITHOUT PROJECT  
INTERSECTIONS #1 TO #12

DATE:

JANUARY 2011

PROJECT NO:

5-91M-15338C-08-01

REV. NO.:

-

FIGURE No.

5-17

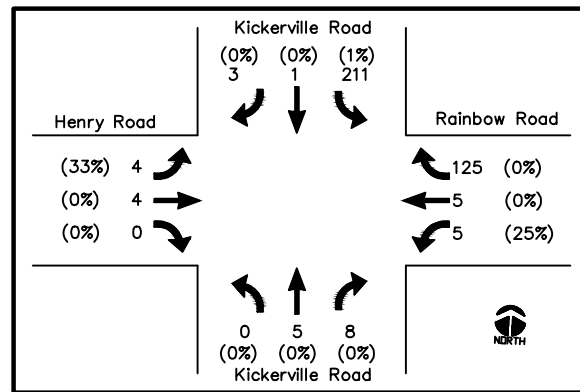

INTERSECTION NO. 13  
HENRY ROAD, RAINBOW ROAD AND KICKERVILLE ROAD  
N.T.S.

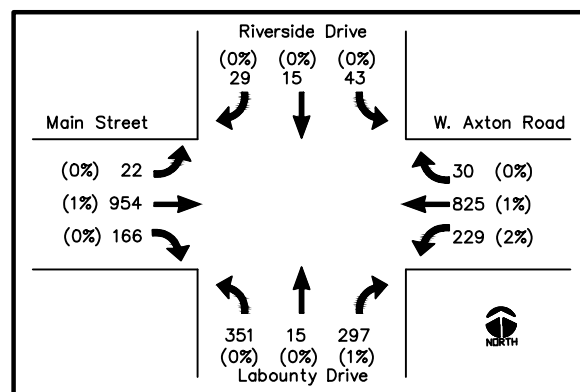

INTERSECTION NO. 14  
MAIN STREET, W. AXTON ROAD,  
RIVERSIDE DRIVE AND LABOUNTY DRIVE  
N.T.S.

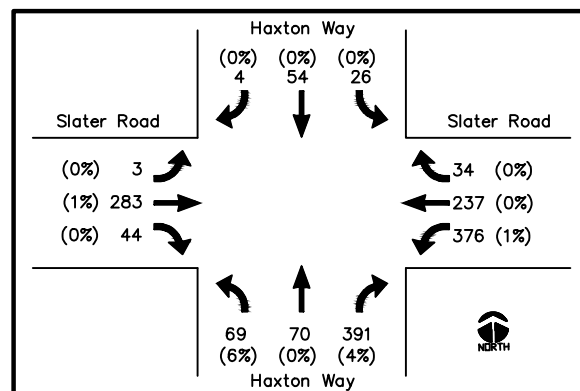

INTERSECTION NO. 15  
SLATER ROAD AND HAXTON WAY  
N.T.S.

**LEGEND:**

- Directional Indicators
- X PM Peak Hour Traffic Count
- (X%) Percent of Heavy Vehicles

CLIENT LOGO



CLIENT:

PACIFIC INTERNATIONAL TERMINALS, INC.

DWN BY: BMM / MJR  
CHK'D BY: BPL  
DATUM: -  
PROJECTION: -  
SCALE: AS SHOWN

PROJECT

GATEWAY PACIFIC TERMINAL

TITLE

FUTURE VOLUMES 2026 ( PM) PEAK HOUR  
WITHOUT PROJECT  
INTERSECTIONS #13 TO #15

DATE: JANUARY 2011

PROJECT NO:  
5-91M-15338C-08-01

REV. NO.: -

FIGURE No.  
5-18





This estimate does not include any trip reduction for carpooling or use of transit, bicycle, or other means. In addition, no employee turnover ratio was used. No other shifts are anticipated to generate PM peak hour trips. Overall, 88 trips during the PM peak hour is a very conservative estimate.

### **Trip Generation—Non-Employee**

All commodities coming into the Terminal would use the rail lines, generating no truck trips for commodities shipping. Any off-loading of commodities would also leave the Terminal on rail lines. From time to time, service, repair, and delivery vehicles would access the Terminal. These trips would be few and typically occur during the day and not during the PM peak hour. Therefore, non-employee trips during the peak hour were not analyzed.

### **Trip Distribution**

Figure 5-19 illustrates the estimated distribution and assignment of project-related vehicular trips from the Terminal. In general, the estimated distribution pattern for outbound trips is 30 percent to the north toward Blaine, Lynden, and I-5; 50 percent to the east toward Ferndale and I-5; and 20 percent to the south and southwest toward Bellingham (KJS Associates, Inc. 1996). The inbound (AM peak) trip distribution would follow the opposite route.

### **Peak Period Vehicular Traffic Impacts**

Figures 5-20 and 5-21 display the PM peak-hour roadway traffic associated with the proposed development. Figures 5-22 and 5-23 display the PM peak-hour roadway traffic associated with the proposed development when background traffic is included.

Tables 5-23 and 5-24 show the effects of increased, project-related roadway traffic on Intersections 1–15 during the PM peak hour.

Tables 5-23 and 5-24 increased road and street traffic from the project would decrease the LOS at only one intersection (Intersection 12), and that intersection would remain at a high LOS of B even with the project impact. Two intersections (Intersections 8 and 9) would operate at LOS F even without the project.

It is important to understand that the LOS and the delay shown in the tables represent the average delay for each vehicle during the PM peak hour. What may seem like an insignificant change in delay can have a larger change to LOS. Table 5-20 illustrates how a modest delay can change LOS at a two-way, stop controlled intersection.

Projected traffic volume in 2026 without development of the Terminal would result in six intersections (Intersections 2, 4, 7, 8, 9, and 14) exceeding the established Whatcom County limit for V/C ratio. The

impacts of the Terminal development on V/C ratio at these six intersections are minor (0.05 at the most). In some cases, no impact is indicated. In general, the existing roadway network has adequate capacity for the project, and most locations have adequate capacity for the projected future growth.

### **Rail Crossings and Estimated Future Delay**

With an estimated maximum of 9 trains per day (18 train movements), the project is expected to result in one additional freight train per day in the area during the PM peak hour. This estimate was used to analyze PM peak hour vehicle delay due to rail traffic for both the Custer Spur and Bellingham Subdivision main lines, both with and without the Terminal.

For the one additional train, an estimated maximum of 10 minutes of delay for road traffic at each of the at-grade rail crossings located near intersections 1, 2, 5, 6, and 13 would occur for a driver who arrives just as the train approaches. The assumed increased delay of 6 to 10 minutes is based on the estimated length and speed of the train. This additional train would also cause approximately 2 minutes of delay for vehicles at intersections 4, 9, and 10, based on the speed of the train at those locations. Passenger train volume and frequency would remain unchanged, as the project would not generate any additional passenger train trips.

A summary of the analysis of 2026 operating conditions both with and without the project is shown in Table 5-25.

As expected, the potential of an additional 10-minute train blockage during the PM peak hour increases the overall delay at Intersections 2, 5, 6, and 13. The LOS is lowered by two levels at Intersections 5, 6, and 13.

As shown in the analysis, when factoring in the possible delay due to a train crossing during the PM peak hour, the intersections may actually operate at a lower LOS than indicated by the traffic models.

### **Site Access and Circulation**

Site access to the Terminal would be provided at the main entrance to the Terminal via a new paved access road that connects at the intersection of Gulf Road and Henry Road. Other roads within the Terminal would be constructed to access the facilities. A secondary access point would be provided through an at-grade rail crossing at the southeast corner of the East Loop. This secondary access would be blocked when trains are present.

### **Site Terminal Parking and Queuing**

Based on the employee numbers provided, peak parking demand in 2026 is estimated at 160 parking stalls. All parking would be provided within the Terminal property. On-site queuing may increase during the PM peak hour as employees leave work. This queuing is not expected to affect the external roadway system, but may affect the delay experienced by workers leaving the Terminal.

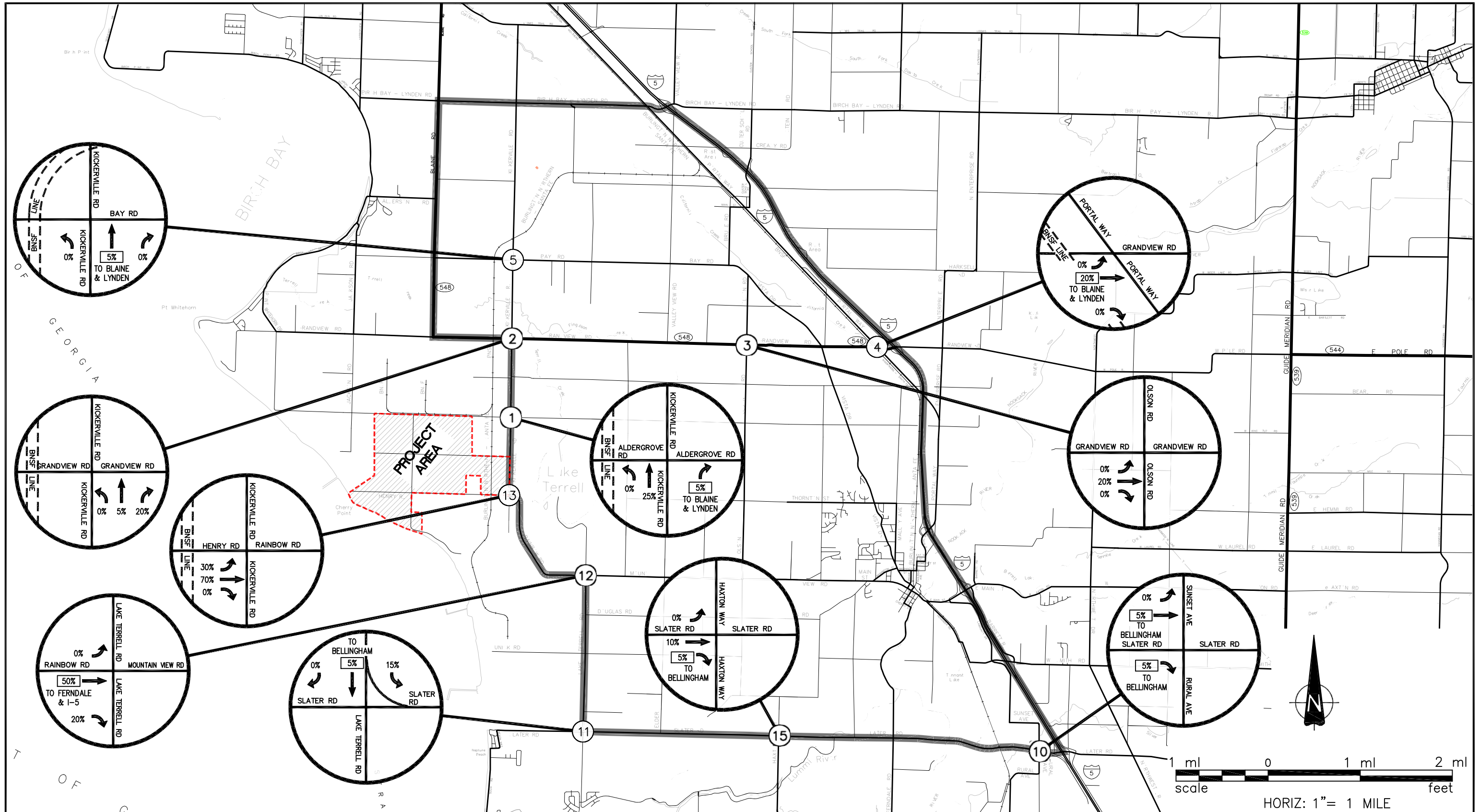

<b>LEGEND:</b>	
	Employee Trips
	Analyzed Intersection
	Percent of Trips Leaving Study Area

CLIENT LOGO

Pacific International Terminals  
A Carris Enterprise

CLIENT:  
**PACIFIC INTERNATIONAL TERMINALS, INC.**

DWN BY: BMM / MJR  
CHK'D BY: BPL  
DATUM:  
PROJECTION:  
SCALE: AS SHOWN

PROJECT  
**GATEWAY PACIFIC TERMINAL**

TITLE  
**OUTBOUND EMPLOYEE TRIP DISTRIBUTION**

DATE: JANUARY 2011  
PROJECT NO: 5-91M-15338C-08-01  
REV. NO.:  
FIGURE No. 5-19



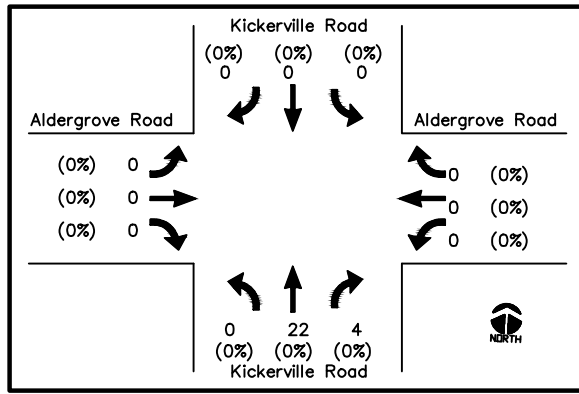

INTERSECTION NO. 1  
ALDERGROVE ROAD AND  
KICKERVILLE ROAD  
N.T.S.

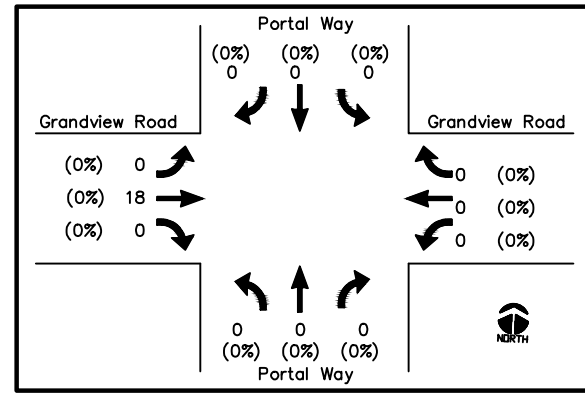

INTERSECTION NO. 4  
GRANDVIEW ROAD AND PORTAL WAY  
N.T.S.

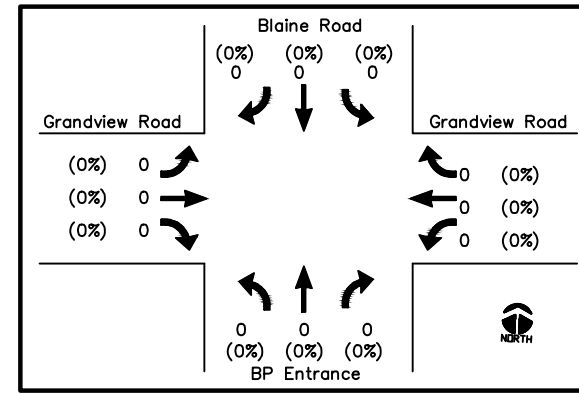

INTERSECTION NO. 7  
GRANDVIEW ROAD, BLAINE ROAD AND BP ENTRANCE  
N.T.S.

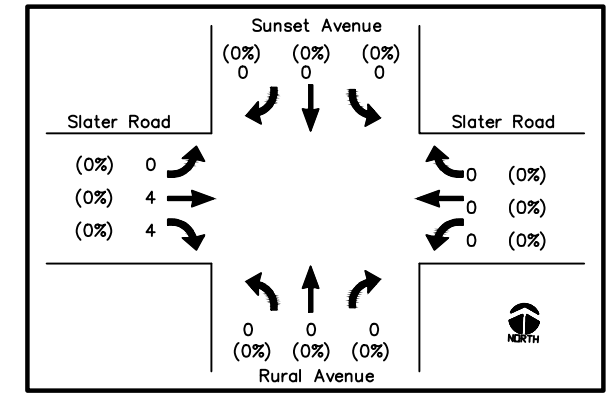

INTERSECTION NO. 10  
SLATER ROAD, RURAL AVENUE AND SUNSET AVENUE  
N.T.S.

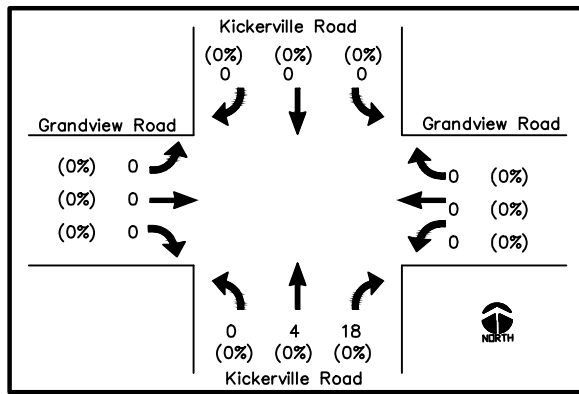

INTERSECTION NO. 2  
GRANDVIEW ROAD AND  
KICKERVILLE ROAD  
N.T.S.

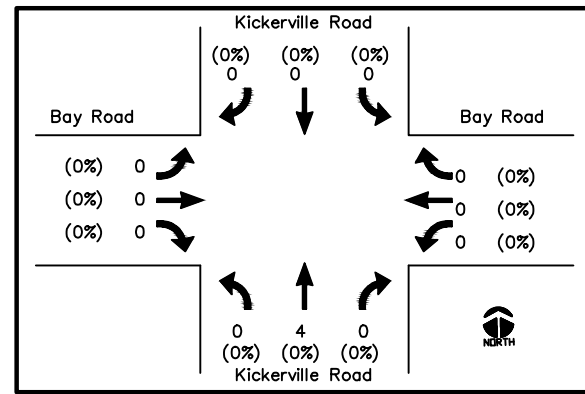

INTERSECTION NO. 5  
BAY ROAD AND KICKERVILLE ROAD  
N.T.S.

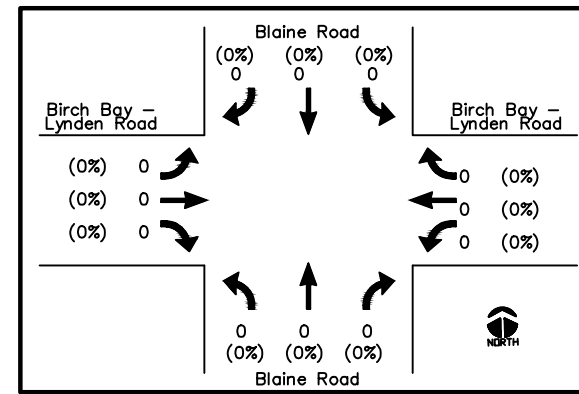

INTERSECTION NO. 8  
BIRCH BAY - LYNDEN ROAD AND BLAINE ROAD  
N.T.S.

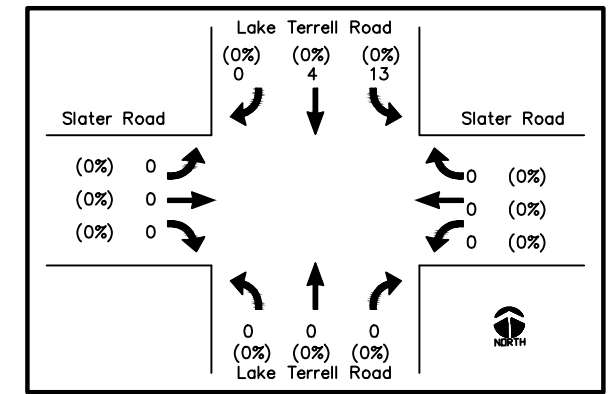

INTERSECTION NO. 11  
SLATER ROAD AND LAKE TERRELL ROAD  
N.T.S.

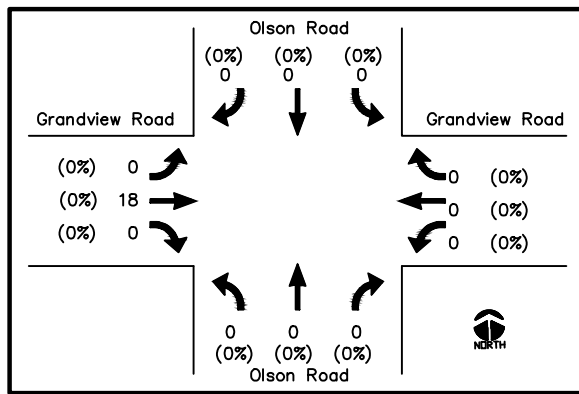

INTERSECTION NO. 3  
GRANDVIEW ROAD AND OLSON ROAD  
N.T.S.

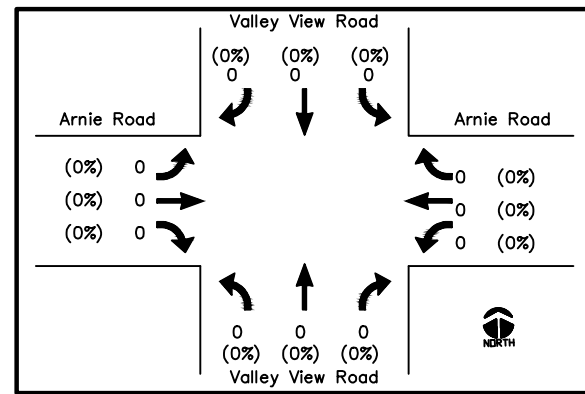

INTERSECTION NO. 6  
ARNIE ROAD AND VALLEY VIEW ROAD  
N.T.S.

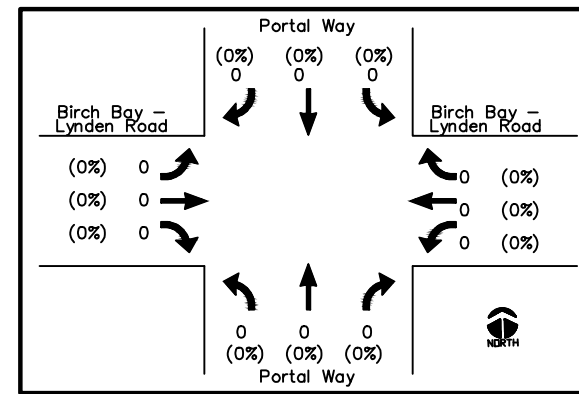

INTERSECTION NO. 9  
BIRCH BAY - LYNDEN ROAD AND PORTAL WAY  
N.T.S.

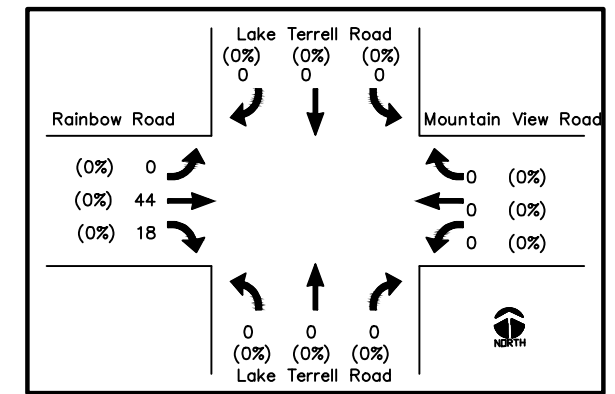

INTERSECTION NO. 12  
RAINBOW ROAD, MOUNTAIN VIEW ROAD AND  
LAKE TERRELL ROAD  
N.T.S.

**LEGEND:**  
 Directional Indicators  
 X PM Peak Hour Traffic Count  
 (X%) Percent of Heavy Vehicles



CLIENT:  
PACIFIC INTERNATIONAL TERMINALS, INC.

DWN BY: BMM / MJR  
 CHK'D BY: BPL  
 DATUM:  
 PROJECTION:  
 SCALE: AS SHOWN

PROJECT  
GATEWAY PACIFIC TERMINAL  
 TITLE  
FUTURE VOLUMES 2026 ( PM) PEAK HOUR  
PROJECT RELATED VOLUME  
INTERSECTIONS #1 TO #12

DATE: JANUARY 2011  
 PROJECT NO: 5-91M-15338C-08-01  
 REV. NO.:  
 FIGURE No. 5-20



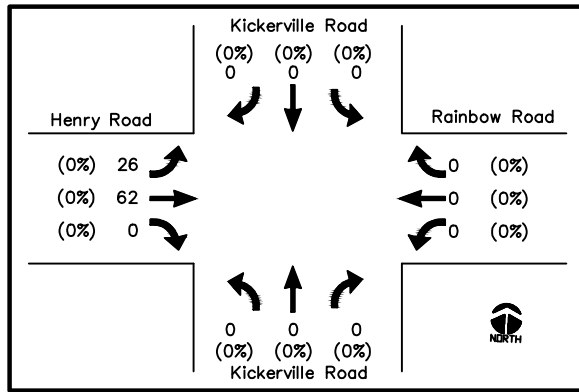

INTERSECTION NO. 13  
HENRY ROAD, RAINBOW ROAD AND KICKERVILLE ROAD  
N.T.S.

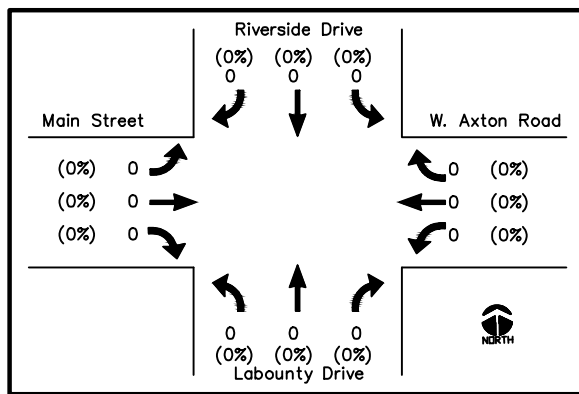

INTERSECTION NO. 14  
MAIN STREET, W. AXTON ROAD,  
RIVERSIDE DRIVE AND LABOUNTY DRIVE  
N.T.S.

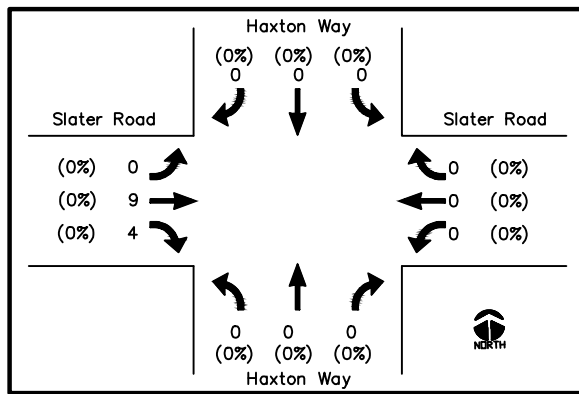

INTERSECTION NO. 15  
SLATER ROAD AND HAXTON WAY  
N.T.S.

**LEGEND:**  
 Directional Indicators  
 X PM Peak Hour Traffic Count  
 (X%) Percent of Heavy Vehicles



CLIENT: PACIFIC INTERNATIONAL TERMINALS, INC.

DWN BY: BMM / MJR  
 CHK'D BY: BPL  
 DATUM: -  
 PROJECTION: -  
 SCALE: AS SHOWN

PROJECT: GATEWAY PACIFIC TERMINAL  
 TITLE: FUTURE VOLUMES 2026 ( PM) PEAK HOUR  
 PROJECT RELATED VOLUME  
 INTERSECTIONS #13 TO #15

DATE: JANUARY 2011  
 PROJECT NO: 5-91M-15338C-08-01  
 REV. NO.: -  
 FIGURE No. 5-21





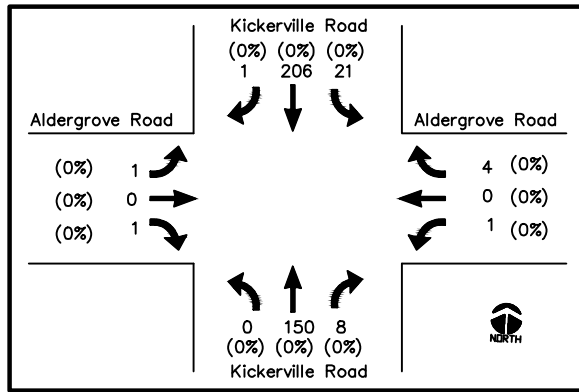

INTERSECTION NO. 1  
ALDERGROVE ROAD AND  
KICKERVILLE ROAD  
N.T.S.

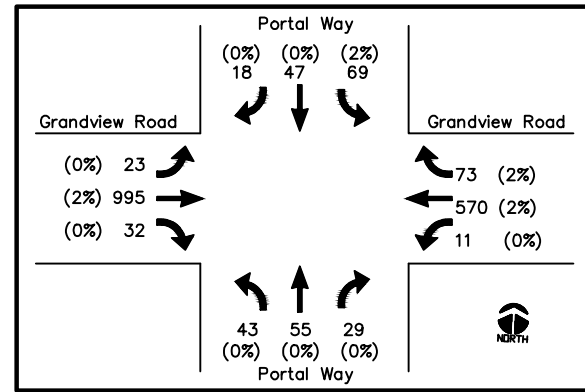

INTERSECTION NO. 4  
GRANDVIEW ROAD AND PORTAL WAY  
N.T.S.

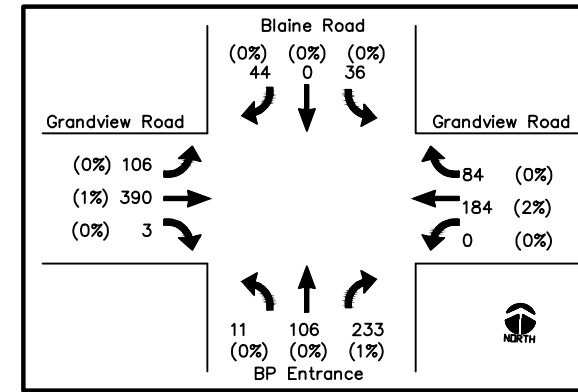

INTERSECTION NO. 7  
GRANDVIEW ROAD, BLAINE ROAD AND BP ENTRANCE  
N.T.S.

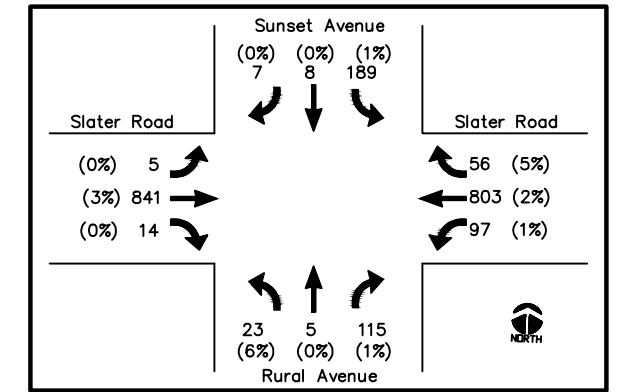

INTERSECTION NO. 10  
SLATER ROAD, RURAL AVENUE AND SUNSET AVENUE  
N.T.S.

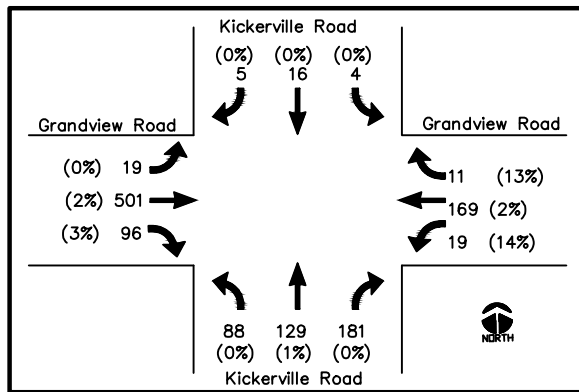

INTERSECTION NO. 2  
GRANDVIEW ROAD AND  
KICKERVILLE ROAD  
N.T.S.

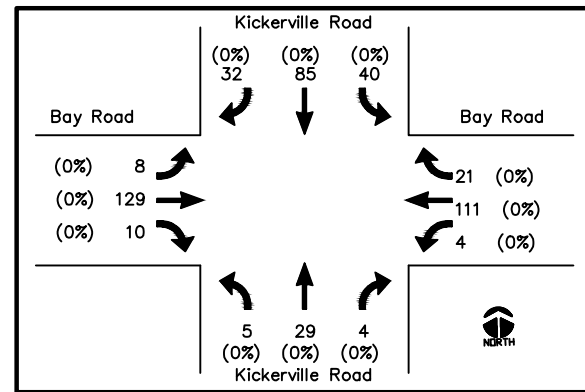

INTERSECTION NO. 5  
BAY ROAD AND KICKERVILLE ROAD  
N.T.S.

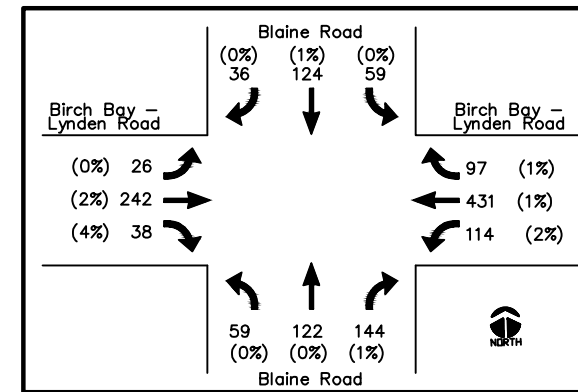

INTERSECTION NO. 8  
BIRCH BAY - LYNDEN ROAD AND BLAINE ROAD  
N.T.S.

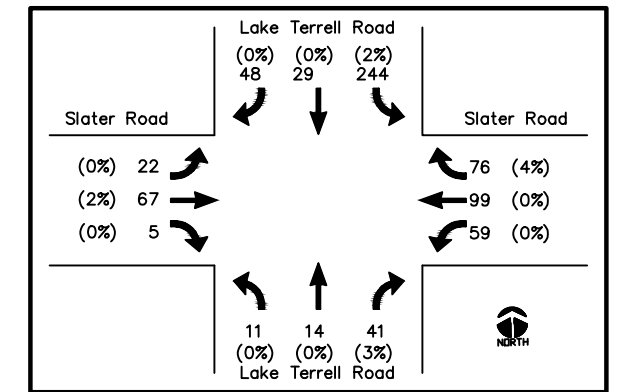

INTERSECTION NO. 11  
SLATER ROAD AND LAKE TERRELL ROAD  
N.T.S.

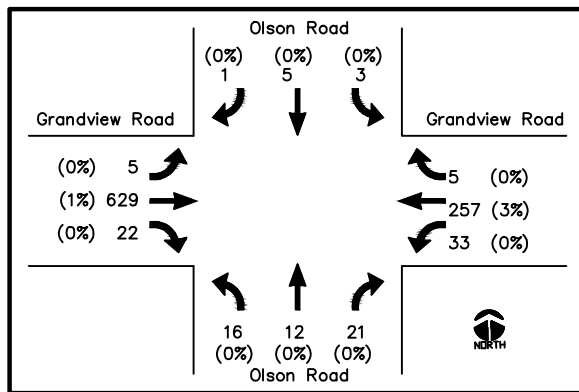

INTERSECTION NO. 3  
GRANDVIEW ROAD AND OLSON ROAD  
N.T.S.

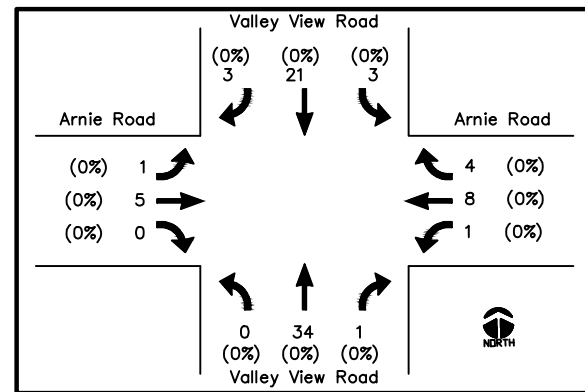

INTERSECTION NO. 6  
ARNIE ROAD AND VALLEY VIEW ROAD  
N.T.S.

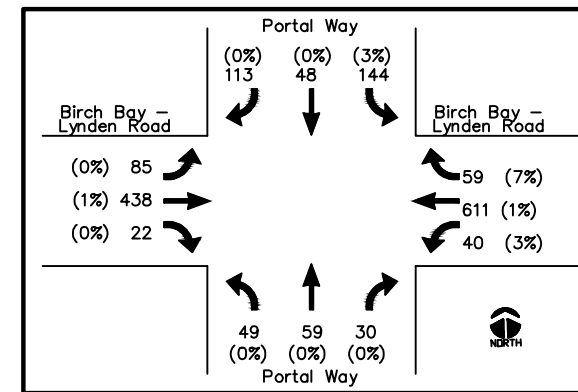

INTERSECTION NO. 9  
BIRCH BAY - LYNDEN ROAD AND PORTAL WAY  
N.T.S.

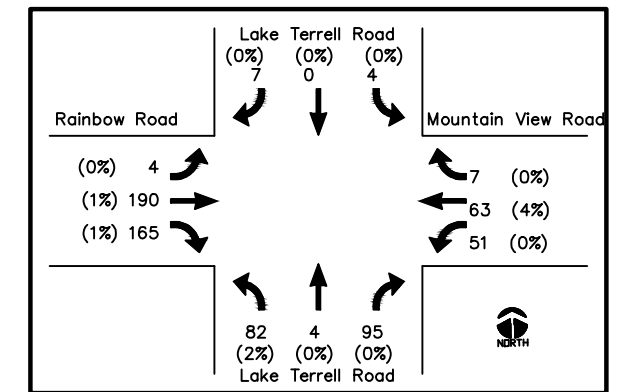

INTERSECTION NO. 12  
RAINBOW ROAD, MOUNTAIN VIEW ROAD AND  
LAKE TERRELL ROAD  
N.T.S.

LEGEND:

- Directional Indicators
- X PM Peak Hour Traffic Count
- (X%) Percent of Heavy Vehicles

CLIENT LOGO



Pacific International  
Terminals  
A Carrix Enterprise

CLIENT:

PACIFIC INTERNATIONAL TERMINALS, INC.

DWN BY:

BMM / MJR

CHK'D BY:

BPL

DATUM:

PROJECTION:

SCALE:

AS SHOWN

PROJECT

GATEWAY PACIFIC TERMINAL

TITLE

FUTURE VOLUMES 2026 ( PM) PEAK HOUR  
VOLUME WITH PROJECT  
INTERSECTIONS #1 TO #12

DATE:

JANUARY 2011

PROJECT NO:

5-91M-15338C-08-01

REV. NO.:

-

FIGURE No.

5-22



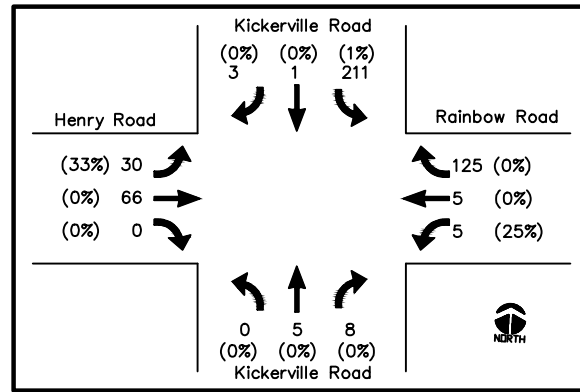

INTERSECTION NO. 13  
HENRY ROAD, RAINBOW ROAD AND KICKERVILLE ROAD  
N.T.S.

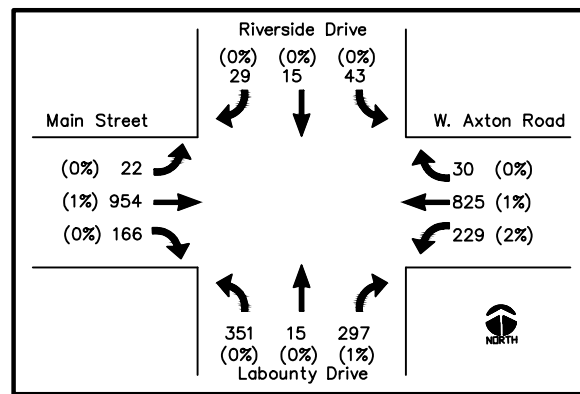

INTERSECTION NO. 14  
MAIN STREET, W. AXTON ROAD,  
RIVERSIDE DRIVE AND LABOUNTY DRIVE  
N.T.S.

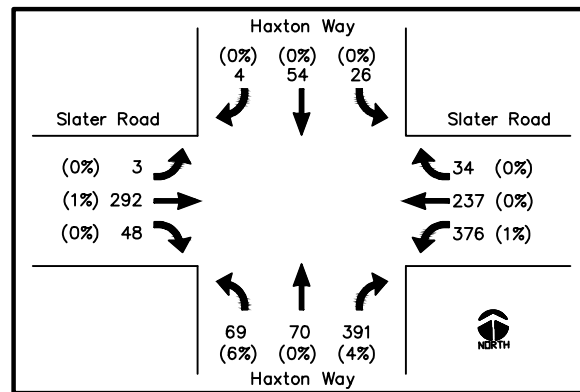

INTERSECTION NO. 15  
SLATER ROAD AND HAXTON WAY  
N.T.S.

**LEGEND:**

- Directional Indicators
- X PM Peak Hour Traffic Count
- (X%) Percent of Heavy Vehicles

CLIENT LOGO



CLIENT:

PACIFIC INTERNATIONAL TERMINALS, INC.

DWN BY: BMM / MJR  
CHK'D BY: BPL  
DATUM: -  
PROJECTION: -  
SCALE: AS SHOWN

PROJECT

GATEWAY PACIFIC TERMINAL

TITLE

FUTURE VOLUMES 2026 ( PM) PEAK HOUR  
VOULUME WITH PROJECT  
INTERSECTIONS #13 TO #15

DATE: JANUARY 2011

PROJECT NO:  
5-91M-15338C-08-01

REV. NO.: -

FIGURE No.  
5-23



**Table 5-23 2026 PM Peak Hour Level of Service with and without Project**

<b>Intersection Number</b>	<b>Description</b>	<b>Volume Without Project</b>	<b>LOS Without Project</b>	<b>Volume With Project</b>	<b>LOS With Project</b>
1	Aldergrove Road and Kickerville Road	367	A	393	A
2	Grandview Road and Kickerville Road	1,216	C	1,238	C
3	Grandview Road and Olson Road	991	A	1,009	A
4	Grandview Road and Portal Way	1,947	C	1,965	C
5	Bay Road and Kickerville Road	474	A	478	A
6	Arnie Road and Valley View Road	81	A	81	A
7	Grandview Road and Blaine Road	1,197	D	1,197	D
8	Birch Bay-Lynden Road and Blaine Road	1,492	F*	1,492	F
9	Birch Bay-Lynden Road and Portal Way	1,698	F*	1,698	F
10	Slater Road and Sunset Avenue/Rural Avenue	2,155	C	2,163	C
11	Slater Road and Lake Terrell Road	698	A	715	A
12	Rainbow Road/Mountain View Road and Lake Terrell Road	610	A	672	B
13	Rainbow Road/Henry Road and Kickerville Road	371	A	459	A
14	Main Street/West Axton Road and Riverside Drive/Labounty Drive	2,976	C	2,976	C
15	Slater Road and Haxton Way	1,591	B	1,604	B

\* LOS meets or exceeds the Whatcom County limit with existing traffic without the project improvements.

### **Indirect Effects**

Increased vehicle traffic may affect some intersections outside of the study area. The project traffic traveling through those intersections is expected to result in a small (less than 1 percent) increase in traffic at those intersections. The project trips are not expected to affect the level of service of those intersections significantly.

#### **5.6.2.3 Potential Effects on Rail Transportation**

The potential effects of the proposed project on rail transportation are evaluated in the following sections.

**Table 5-24 2026 PM Peak Hour Delay, and Volume/Capacity (V/C) Ratio with and without Project**

Intersection Number	Description	Avg. Delay Without Project (seconds)	V/C Ratio Without Project <sup>1</sup>	Avg. Delay With Project (seconds)	V/C Ratio With Project	V/C Ratio Limit <sup>2</sup>
1	Aldergrove Road and Kickerville Road	0.7	.02	0.7	.02	.75
2	Grandview Road and Kickerville Road	50.3	1.23 <sup>*</sup> - NB	58.7	1.28	.75
3	Grandview Road and Olson Road	1.8	.20	1.8	.20	.75
4	Grandview Road and Portal Way	25.9	.91 <sup>*</sup> - EB	26.8	.92	.75
5	Bay Road and Kickerville Road	5.2	.26	5.2	.26	.75
6	Arnie Road and Valley View Road	7.2	.04	7.2	.04	.75
7	Grandview Road and Blaine Road	26.1	.94 <sup>*</sup> - NB	26.1	.94	.75
8	Birch Bay-Lynden Road and Blaine Road	111.4	1.43 <sup>*</sup> -WB	111.4	1.43	.90
9	Birch Bay-Lynden Road and Portal Way	154.5	1.49 <sup>*</sup> - WB	154.5	1.49	.90
10	Slater Road and Sunset Avenue/Rural Avenue	20.1	.84	20.3	.85	.90
11	Slater Road and Lake Terrell Road	11.4	.62	12.4	.65	.75
12	Rainbow Road/ Mountain View Road and Lake Terrell Road	9.6	.40	10.4	.47	.75
13	Rainbow Road/Henry Road and Kickerville Road	8.6	.30	8.9	.31	.75
14	Main Street/West Axton Road and Riverside Drive/Labounty Drive	33.3	.95 <sup>*</sup> - EB	33.3	.95	.75
15	Slater Road and Haxton Way	10.3	.69	10.5	.69	.75

1. V/C = volume/capacity ratio; NB = northbound; EB = eastbound; WB = westbound.

2. Limit as set by Whatcom County Comprehensive Plan (2010), Map #14A - Level of Service Standards Volume/Capacity Ratio.

\* Volume/capacity ratio of one of the approaches meets or exceeds the Whatcom County limit with existing traffic without the project improvements. Includes approach direction that fails.

**Table 5-25 2026 PM Peak Hour Level of Service and Delay Without and With Project Volume with Train Crossings**

Intersection Number	Description	Volume <sup>1</sup>	Without Project		Volume <sup>1</sup>	With Project		Diff. Delay (seconds)
			LOS	Avg. Delay (seconds)		LOS	Avg. Delay (seconds)	
1	Aldergrove Road and Kickerville Road	3	A	0.7	3	A	0.7	0.0
2	Grandview Road and Kickerville Road	878	F*	61.9	878	F	101.7	39.8
4	Grandview Road and Portal Way	1,663	D	31.9	1,681	D	34.7	2.8
5	Bay Road and Kickerville Road	466	D	25.8	470	F	78.6	52.8
6	Arnie Road and Valley View Road	66	D	25.1	81	F	66.3	41.2
9	Birch Bay-Lynden Road and Portal Way	1,318	F*	148.3	1,318	F	165.9	17.6
10	Slater Road and Sunset Avenue/Rural Avenue	1,685	D	26.0	1,693	D	28.0	2.0
13	Rainbow Road/Henry Road and Kickerville Road	16	A	8.9	16	C	20.3	11.4

<sup>1</sup> Volume of PM peak hour traffic potentially blocked by train movements. Value represents only those turning movements that could be blocked by a train.

\* Intersection fails without any train delay calculations added.

### Rail Transportation Effects during Construction

While some specialty items needed for construction of the Terminal may arrive via rail, the majority of the construction material would arrive by road or ship. No significant changes in existing rail transportation conditions would be expected to occur because of the project construction process.

### Rail Transportation Effects during Operation

The BNSF Railway would provide the main freight access and trains to deliver and export commodities. The East Loop would branch from the Custer Spur just north of the Elliot Rail Yard near

Aldergrove Road. The West Loop would branch from the Custer Spur via a new switch north of Aldergrove Road and approximately 4,000 feet east of Power Plant Road.

### ***Loaded Trains per Day***

At full operational capacity, up to 9 trains (18 train movements) per day may use the terminal. Most trains serving the Terminal are anticipated to be approximately 8,500 feet long. Although the Terminal would be designed to have the capacity to stage trains up to 8,500 feet, initially trains would be no more than 7,000 feet long. The overall rail system has adequate capacity to handle the rail needed for the Terminal, though improvements are proposed to the Custer Spur by BNSF Railway to accommodate the future, local rail needs within the Cherry Point Industrial Area.

### ***Existing Rail Operations during the PM Peak Hour***

Based on information from BNSF Railway, estimates of the operating characteristic of the Custer Spur and the Bellingham main line during the 4 to 6 PM period from Monday through Friday on a typical day are provided below. This period encompasses the PM peak hour analyzed in the roadway section and for the LOS comparisons. On a typical day, operations are estimated as:

- Custer Spur
  - Train Length: 50 to 70 cars typical range (3,500 to 4,800 feet long)
  - Average Train Speed: 10 mph
  - Trains per Time Period: generally one train per shift working at existing industries at Cherry Point with generally up to 50 cars awaiting pickup on the BP lead
  - Frequency: Daily
- Bellingham Subdivision Line (main line)
  - Freight Trains
    - Train Length: 100 cars average (6,700 to 7,000 feet long)
    - Average Train Speed: at intersection 9 is 60 mph and at intersection 10 is 50 mph
    - Average Number of Trains: 5 freight
    - Frequency: Daily
  - Passenger Trains
    - Train Length: 14 cars average (up to 1,100 feet long)
    - Average Train Speed: at intersection 9 is 79 mph and at intersection 10 is 70 mph



- Average Number of Trains: 2
- Frequency: Daily

### ***Existing Delay to Vehicles Due to Rail Operations***

The existing delay experienced by roadway users due to trains was analyzed for the PM peak hour (4:15 to 5:15 PM) period, as that is when traffic congestion is greatest in the project area. The analysis was presented in Section 5.6.1.2 and results are shown in Table 5-21.

As shown in the analysis when factoring in the possible delay due to a train crossing during the PM peak hour, the intersections may actually operate at a lower LOS than indicated by the traffic models.

It should be noted that a train would not necessarily affect the PM peak hour every day, and the durations may be different from day to day. The information presented in the previous analysis is an estimate of typical rail operating conditions and their impacts to vehicular traffic.

## **5.6.3 Proposed Design Features Intended to Reduce Impacts**

### ***5.6.3.1 Suggested Improvements for Intersections Not Affected by the Project***

Based on the analysis results, two intersections (Intersections 8 and 9) will operate at LOS F in the year 2026 with or without development of the Terminal. The proposed project does not send any vehicles through these intersections, but they were analyzed due to their proximity to the site. In the analysis at projected buildout volumes, the PM peak hour LOS for these intersections would improve by enhancing traffic controls from TWSC to signalized control, as shown in Table 5-26.

**Table 5-26 2026 PM Peak Hour Level of Service with and without Signalization Improvements**

<b>Intersection Number</b>	<b>Description</b>	<b>Delay Without Improvements</b>	<b>LOS Without Improvements</b>	<b>Delay With Improvements</b>	<b>LOS With Improvements</b>
8	Birch Bay-Lynden Road and Blaine Road	111.4	F <sup>+</sup>	18.2	B
9	Birch Bay-Lynden Road and Portal Way	154.5	F <sup>+</sup>	17.6	B

Projected volumes in 2026 without the project cause six intersections (Intersections 2, 4, 7, 8, 9, and 14) to exceed the established Whatcom County limit for V/C ratio. The impacts to V/C ratio caused by the project would be minor (0.05 at the most); in some cases no impact is indicated.

It is suggested that Whatcom County work with WSDOT and other regional users to prioritize improvements that would keep the V/C ratio under the established limits as growth occurs. Pacific International Terminals will work with Whatcom County to determine a fair contribution to required

improvements based on the Terminal's anticipated traffic impacts to the background traffic flow at those locations. As described above, all intersections except two (Intersections 8 and 9) would operate at LOS D or better during the PM peak hour in year 2026 without a train crossing during that time period, even with the additional project-related vehicle traffic.

Major roads such as Grandview Road (SR 548) currently experience periods of extended blockage. This blockage would be monitored and not significantly increased due to Terminal operations.

The train volumes, timing, and resulting delay to vehicle traffic should be monitored as the Terminal capacity grows. Terminal operators would work with Whatcom County to develop a strategy for monitoring rail usage to determine the impacts of the Terminal on the surrounding infrastructure. As the train volumes increase, appropriate mitigation measures may need to be identified and implemented through 2026 when the Terminal is operating at full capacity.

## **5.7 AIR QUALITY**

Air quality is generally assessed in terms of whether concentrations of air pollutants are higher or lower than ambient air quality standards established to protect human health and welfare. Three agencies have jurisdiction over ambient air quality in the project area: the US Environmental Protection Agency (EPA), Ecology, and the Northwest Clean Air Agency (NWCAA). These agencies have established regulations that govern both the concentrations of regulated pollutants in the outdoor air and contaminant emissions from some air emission sources.

### **5.7.1 Regulatory Overview and Air Quality Guidelines**

To track air quality conditions, Ecology and NWCAA maintain a network of monitoring stations throughout the region. These stations are typically located where air quality problems may occur, and are therefore usually located in or near urban areas or close to specific large air pollution sources. Other agency-operated stations are used to indicate regional air pollution levels, and some private facilities operate their own monitoring stations. Based on "official" monitoring data collected over a period of years, the state (Ecology) and federal (EPA) agencies designate regions as being "attainment" or "nonattainment" areas for designated "criteria pollutants" under the federal Clean Air Act. Attainment status is a measure of whether air quality in an area "attains" (i.e., complies with) the National Ambient Air Quality Standard (NAAQS) established for criteria air pollutants. Criteria air pollutants include ozone, particulate matter (PM), carbon monoxide (CO), nitrogen oxides, sulfur dioxide, and lead. Regions or locales where air pollutant concentrations exceed one or more standards are designated as nonattainment for specific pollutants. Regions that were once nonattainment that have since attained the standard are considered "maintenance" areas.

The project area is located in a region designated as attainment for all monitored air pollutants. Criteria air pollutants that are potentially relevant to the proposed Gateway Pacific Terminal and the respective air quality standards are discussed further below.

## 5.7.2 Affected Environment

### 5.7.2.1 Existing Air Quality

Existing sources of air pollution in the project area include several industrial sources (refineries, aluminum works, and bulk fuel storage facilities), local traffic sources, and residential wood burning associated with low-density residential development. Residential wood burning produces a variety of air emissions, including large quantities of fine particulate matter ( $PM_{10}$  and  $PM_{2.5}$ )<sup>2</sup>. With typical vehicular traffic, the air pollutant of concern is carbon monoxide (CO). Other pollutants generated by vehicle exhaust include the ozone precursors (hydrocarbons and nitrogen oxides [ $NO_x$ ]), fine particulate matter ( $PM_{10}$  and  $PM_{2.5}$ ) also generated by tire abrasion on roadway pavement (or unpaved areas), and sulfur dioxide ( $SO_2$ ). The amounts of particulate matter generated by individual vehicles are small compared with other sources (e.g., a wood-burning stove) and concentrations of  $SO_2$  and  $NO_x$  are usually not high, except near large industrial facilities. Due to the general lack of transportation congestion in Whatcom County, regulated industrial sources likely comprise the largest contributors to ambient pollutant concentrations. Specific pollutants are discussed further below. Concentrations of air pollutants measured near the project area are summarized in Table 5-27.

### Carbon Monoxide

Carbon monoxide (CO) is the product of incomplete combustion. It is generated by transportation sources and other fuel-burning activities, such as residential space heating, especially heating with solid fuels like coal or wood. Carbon monoxide is the pollutant usually used as an indicator of air pollution from transportation sources because it is the pollutant emitted in the greatest quantity for which short-term health standards exist. Carbon monoxide is a pollutant whose impact is usually localized, and CO concentrations typically diminish within a short distance of roads. The highest ambient concentrations of CO usually occur near congested roadways and intersections during periods of air stagnation (often in winter).

No measured violations of the CO ambient air quality standard have occurred within Washington State for several years. The project area is located in a region considered in attainment for CO.

---

2.  $PM_{2.5}$  and  $PM_{10}$  are particulate matter or particles with diameters less than or equal to about 2.5 micrometers ( $\mu m$ ) or 10  $\mu m$ , respectively.

**Table 5-27 Summary of Measured Ambient Pollutant Concentrations**

Pollutant	Monitoring Location	Averaging Period	Measured Value	Unit	Year
PM <sub>2.5</sub>	Bellingham - Yew Street	Annual average, NAAQS	6.0	µg/m <sup>3</sup>	2010
PM <sub>2.5</sub>	Bellingham - Yew Street	24-hour, NAAQS	15.8	µg/m <sup>3</sup>	2010
NO <sub>2</sub>	Langley, British Columbia	Annual average, NAAQS	0.007	ppm	2008
NO <sub>2</sub>	Langley, British Columbia	1-hour, NAAQS	0.031	ppm	2008
SO <sub>2</sub>	BP Cherry Point Refinery	1-hour, 99th percentile	103.6	µg/m <sup>3</sup>	2008
SO <sub>2</sub>	Bellingham - Chestnut Street	Annual average, NAAQS	43.3	µg/m <sup>3</sup>	1999
SO <sub>2</sub>	Bellingham - Chestnut Street	24-hour maximum, NAAQS	41.2	µg/m <sup>3</sup>	1999
SO <sub>2</sub>	Bellingham - Chestnut Street	1-hour, NAAQS	103.4	µg/m <sup>3</sup>	1999
Ozone	Custer – Loomis	8-hour, NAAQS	0.047	ppm	2010
Ozone	Custer – Loomis	1-hour maximum, NAAQS	0.065	ppm	2010

Source Compiled from publically available information by ENVIRON International Corporation.

ppm parts per million

µg/m<sup>3</sup> micrograms per cubic meter;

**Ozone**

Ozone is a highly reactive form of oxygen created by sunlight-activated chemical transformations of nitrogen oxides and volatile organic compounds (hydrocarbons) in the atmosphere. Ozone problems tend to be regional in nature because the atmospheric chemical reactions that produce ozone occur over a period of time, and because during the delay between emission and ozone formation, ozone precursors can be transported far from their sources. Transportation sources, including marine vessels, locomotives, and trucks and other vehicles, are some of the sources that produce ozone precursors. Because ozone is not emitted directly, only very sophisticated air quality models are capable of considering ozone formation in the atmosphere, and such models are typically used for regional assessments of air quality plans instead of for project-specific reviews. So unlike the other criteria air pollutants discussed here, ozone will not be considered in the air quality impact analysis for the proposed project.

In the past, due to violations of the federal ozone standard, the central Puget Sound region was designated as nonattainment for ozone based on the 1-hour standard in effect at that time. In 1997, the EPA determined that the Puget Sound ozone nonattainment area had attained the public health-based NAAQS for ozone. EPA therefore re-designated the central Puget Sound region as attainment for ozone and approved the associated air quality maintenance plan. In 2005, EPA revoked the 1-hour ozone standard in most areas of the US, including the Puget Sound region. This action ended the maintenance status of this region. EPA has since adopted a new 8-hour ozone standard, and the region is considered in attainment.

### **Inhalable Particulate Matter – PM<sub>10</sub> and PM<sub>2.5</sub>**

Particulate matter air pollution is generated by industrial activities and operations, fuel combustion sources, such as marine vessels and residential wood burning, motor vehicle engines and tires, and other sources. Federal, state, and local regulations set limits for particulate concentrations in the air based on the size of the particles and the related potential threat to health. When first regulated, particle pollution rules were based on concentrations of “total suspended particulate,” which included all size fractions. As air sampling technology has improved and the importance of particle size and chemical composition have become more clear, ambient standards have been revised to focus on the size fractions thought to be most dangerous to people. Based on the most recent studies, EPA has redefined the size fractions and set new, more stringent standards for particulate matter based on fine and coarse inhalable particulate matter to focus control efforts on the smaller size fractions.

Health-based ambient air quality standards currently exist for PM<sub>10</sub> and for PM<sub>2.5</sub>. The latter size fraction and even smaller (ultra-fine) particles are now considered the most dangerous size fractions of airborne particulate matter because such small particles (e.g., a typical human hair is about 100 µm in diameter) can be breathed deeply into the lungs. In addition, such particles are often associated with toxic substances that are deleterious in their own right and that can adsorb to the particles and be carried into the respiratory system.

With the revocation of the federal annual standard for PM<sup>10</sup> in October 2006, the focus of ambient air monitoring and control efforts related to particle air pollution in the Puget Sound region has been almost entirely on fine particulate matter (PM<sub>2.5</sub>). The measurement station closest to the project site is located in Bellingham. Based on reported data at that location, measured PM<sub>2.5</sub> values are about one-half of the current 24-hour and annual NAAQS. Based on particulate matter measurements over the last few years, EPA in 2009 established a PM<sub>2.5</sub> nonattainment area in Tacoma.<sup>3</sup> No other particulate matter nonattainment areas occur in Washington. PM<sub>2.5</sub> concentrations associated with the proposed project will be analyzed in detail as part of the air quality review.

### **Sulfur Dioxide (SO<sub>2</sub>)**

Sulfur dioxide is a colorless, corrosive gas produced by burning fuels containing sulfur, such as coal and oil, and by industrial processes, such as smelters, paper mills, power plants, and steel manufacturing plants. In general, except near large emission sources, SO<sub>2</sub> levels are typically well below federal standards. Over the past decade, the Puget Sound area has experienced a significant decrease in SO<sub>2</sub> from sources such as pulp mills, cement plants, and smelters. Additionally, levels of sulfur in diesel and gasoline fuels are decreasing due to federal regulations set by EPA.

---

<sup>3</sup> The proposed nonattainment area is called the Wapato Hills-Puyallup River Valley area. Information and maps related to this nonattainment area are available at:  
<http://www.ecy.wa.gov/programs/air/Nonattainment/Nonattainment.htm>.

Existing sources of SO<sub>2</sub> in the project vicinity include the large industrial facilities in the Cherry Point Industrial Urban Growth Area (UGA), vessels in transit and generating electrical power while moored (hoteling), and diesel-fueled vehicles traveling area roadways. Each of these sources contributes to ambient background concentrations of SO<sub>2</sub>. The nearest SO<sub>2</sub> monitoring station was located in Bellingham up until 1999, but BP's Cherry Point Refinery has also measured and reported SO<sub>2</sub> concentrations in more recent years (2008). Measured concentrations near the BP facility (Table 5-27) indicate that background concentrations of this pollutant in the project vicinity are approximately 54 percent of the more limiting 1-hour standard at both locations. Sulfur dioxide concentrations associated with the proposed project will be analyzed in detail as part of the air quality review.

### **Nitrogen Oxides (NO<sub>x</sub>)**

The sum of nitric oxide (NO) and nitrogen dioxide (NO<sub>2</sub>) is commonly called nitrogen oxides or NO<sub>x</sub>. Other oxides of nitrogen, including nitrous acid and nitric acid, are part of the nitrogen oxide family. While NAAQS cover this entire family, NO<sub>2</sub> is the component of greatest interest, and this pollutant is used as the indicator for the larger group of nitrogen oxides. An annual average standard for NO<sub>2</sub> has been in effect for many years.

In February 2010, EPA adopted a new 1-hour standard for NO<sub>2</sub> that became effective in April 2010. Under this new standard, changes occurred in the monitoring method for NO<sub>2</sub>. Instead of being measured directly, ambient concentrations of NO<sub>2</sub> are derived by computation based on measured levels of total reactive nitrogen (NO<sub>y</sub>) minus NO.

NO<sub>2</sub> has not been measured in the project vicinity or within the NWCAA jurisdiction. Measurements in Langley, British Columbia, were used and accepted as background for a recent permitting effort in the NWCAA region. The reported 1-hour and annual average NAAQS values presented in Table 5-27 indicate that background NO<sub>2</sub> concentrations are well below the current NAAQS. Project-related concentrations of NO<sub>2</sub> will be considered as part of the air quality review.

#### **5.7.2.2 Meteorological Conditions and Climate**

Air quality is substantially influenced by climate and meteorological conditions, so prevalent weather patterns are a major factor in long-term air quality conditions. Climate in the project study area is affected by regional geography. The lowlands of Northwest Washington are surrounded by mountains and water bodies. Mountainous regions dominate to the south, east (Cascades), and north (Coast Mountains in Canada), while the Strait of Georgia borders the west. The combination of mountains and water creates a regional meteorology unique to the Pacific Northwest. The climate is dominated by cooler summers that are comparatively dry, and winters that are mild, wet, and cloudy. Annual

average precipitation measured at Bellingham, Washington, reaches 35 inches, with average annual snowfall of 13.7 inches. The wettest months are November, December, and January.

Wind direction and wind speed are complicated by geography. Wind speed and wind direction are measured locally at the BP Cherry Point Refinery. The 5-year meteorological data set (2001–2005) used in a recent modeling effort is represented by the wind rose shown in Figure 5-24. These data suggest a regional pattern of predominately southerly and southwesterly winds, and occasional easterly winds.

Other weather variables influence air quality. Nighttime thermal inversions occur in winter due to the low solar heating of the land, creating stable atmospheric conditions. It is during these very stable atmospheric conditions when little vertical dispersion occurs that monitoring instruments measure high concentrations of air pollutants emitted at ground level. Such pollutants emitted at ground level include CO from motor vehicles and particulate matter from vehicles and wood stoves.

### **5.7.2.3 Energy and Climate Change**

The Council on Environmental Quality (CEQ) and Ecology have issued guidance on considering the effects of greenhouse gas emissions in the evaluation of proposed agency actions under NEPA and SEPA, respectively. These guidance documents advise agencies to identify and quantify meaningful greenhouse gas emissions directly associated with a proposed action. However, CEQ has acknowledged that the utility of analyzing greenhouse gas emissions in an environmental review under NEPA is limited because of the indeterminate linkage between specific environmental or climatological affects and a specific project or emission source. To quantify those emissions that are determined to be meaningful, CEQ references the federal Mandatory Reporting of Greenhouse Gases Rule (40 CFR 98), which requires facilities that emit 25,000 metric tons or more per year of greenhouse gases to submit annual reports to the EPA.

State regulations regarding greenhouse gas emissions from facilities that emit 10,000 metric tons or more per year of greenhouse gases became effective on January 1, 2011, with reporting requirements anticipated to begin in 2012.

As a bulk products terminal, the Gateway Pacific Terminal would not be required to conduct greenhouse gas reporting under current local, state, or federal regulations. While the proposed project would not trigger either the federal or the state reporting requirements, Pacific International Terminals plans to track emissions of greenhouse gases on an annual basis as part of the company's commitment to sustainable business practices. After completion of additional analyses concerning the project, Pacific International Terminals will identify appropriate mitigation measures relating to greenhouse gas emissions.

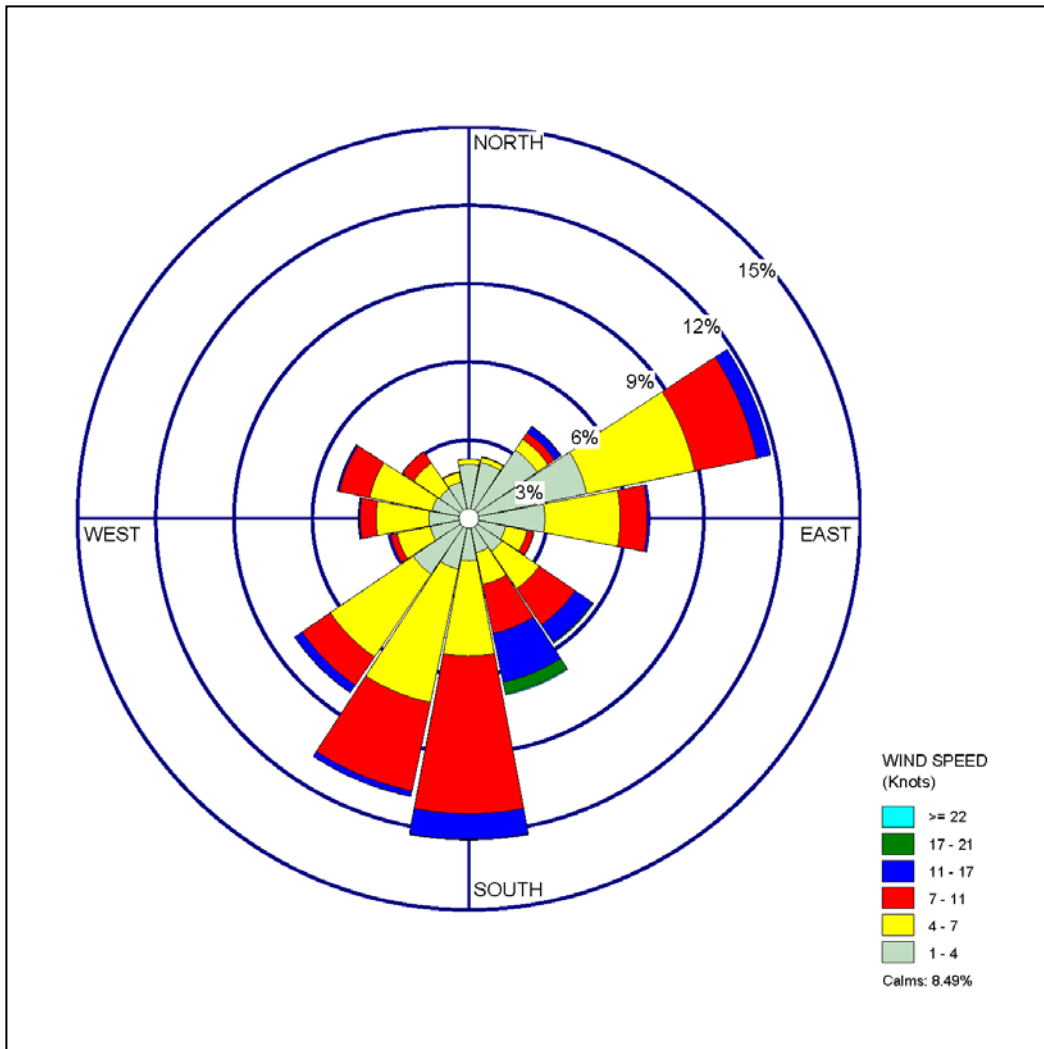

**Figure 5-24 5-Year Wind Rose (BP Cherry Point)**

The Gateway Pacific Terminal would function as a transfer point in an international transportation system. Pacific International Terminals would not own, or process in any way, the commodities that would be received and dispatched by the Terminal. Likewise, the company would have no direct control over the source or destination of individual commodities, or the volumes of such commodities transferred from land-based transportation to oceangoing transportation. The volume, type, and mix of commodities transferred at the Terminal would be determined primarily by international market forces and the business interests of the Terminal’s customers.

**Baseline Greenhouse Gas Emissions Estimate**

Greenhouse gas emissions from the Terminal would include carbon dioxide (CO<sub>2</sub>), methane (CH<sub>4</sub>), and nitrous oxide (N<sub>2</sub>O) associated with such Terminal activities as loading and unloading, stockpile shaping, rail and marine traffic, heating, and construction. Measurements of each gas are converted



to carbon dioxide equivalents (CO<sub>2e</sub>) using EPA-specified calculations. The emissions estimate will be prepared following final design and permitting, so that any final project changes are reflected in these estimates. The emissions estimate shall be performed consistent with the Greenhouse Gas Protocol Corporate Accounting and Reporting Standard, a set of standards developed on behalf of the World Resources Institute and the World Business Council for Sustainable Development. The emissions estimate will include:

- Scope 1 emissions, which are defined as direct emissions from Terminal operations, including periodic maintenance activities; and
- Scope 2 emissions, defined as indirect emissions associated with purchased electrical power.

The baseline report will quantify baseline terminal emissions on a “per ton” basis for products handled at the Terminal and on an estimated “annual total” basis consistent with anticipated operating levels.

Further, the report will identify measures that have been taken to minimize the greenhouse gas footprint of the terminal, and shall evaluate other potentially feasible measures that could be used to further minimize greenhouse gas emissions associated with bulk product handling operations.

### **5.7.3 Effects**

Effects on air quality from construction and operation of the proposed Terminal are currently under study, and that analysis will be completed in late April 2011. This study will consider potential on-site and off-site air quality impacts associated with Terminal operations, including those associated with the proposed commodity-handling infrastructure. The remainder of this section presents an overview of the identified methodology to assess potential short-term and long-term air quality impacts. A qualitative summary of potential air quality effects is included in the following sections. This qualitative summary will be updated with quantitative results upon completion of the air quality impacts study.

#### **5.7.3.1 Construction-Related Air Quality Impacts**

Construction of the Terminal would result in emissions from combustion engines and dust emissions during the extensive grading of the site, during construction of the perimeter berms and wind fencing, during on- and off-site rail line construction, and during construction of other infrastructure, including vessel berths.

Although significant air emissions due to site preparation are unlikely, certain types of air emissions are regulated by the NWCAA. Reasonable Available Control Technology (RACT) to minimize off-site dust emissions must be employed, as stated in NWCAA regulation 550, Preventing Particulate Matter from Becoming Airborne (550.3).

Construction would include extensive grading and excavation of the project area, grading of new roads, and earthwork for construction of rail line embankments. Such activities could result in temporary, localized increases in particulate concentrations due to emissions from construction-related sources. Dust from construction activities, such as excavation, grading, sloping, and filling, would contribute to ambient concentrations of suspended particulate matter. Construction contractor(s) would be required to comply with NWCAA regulations requiring that RACT precautions be taken to minimize dust emissions.

Construction would require the use of heavy trucks, excavators, graders, cranes, pile drivers, and pavers along with a range of smaller equipment, such as generators, pumps, and compressors. Emissions from such sources that use diesel-fueled engines are coming under increasing scrutiny because of their suspected risk to human health. Although there is little or no danger of such emissions resulting in pollutant concentrations that would exceed applicable ambient air quality standards, air pollution control agencies are now urging that emissions from diesel equipment be minimized to the extent practicable. For example, simple cost-effective steps, such as limiting idling time for unused equipment, can serve to reduce construction-related diesel emissions.

Although some construction activities would cause odors, particularly paving operations using tar and asphalt, any odors related to construction would be short-term. Construction contractor(s) would have to comply with NWCAA regulation 535 that prohibits the generation of any odor from any source that may reasonably interfere with any other property owner's use and enjoyment, or which is detrimental to the health, safety, or welfare of person, property, or business. The construction contractor(s) would be required to employ recognized best practices and control equipment to reduce odors to a reasonable minimum.

The project may also be subject to NWCAA regulations pertaining to outdoor burning (Section 502). With implementation of the controls required for the various aspects of construction activities and consistent use of best management practices to minimize on-site emissions, potential impacts from emissions associated with construction activities would be minimized.

### **5.7.3.2 Operational Air Quality Impacts**

During operation of the facility, both on-site and off-site emission sources may contribute to ambient pollutant concentrations. On-site emissions would consist primarily of fugitive dust from commodity loading/unloading and transfer operations, along with emissions from trains and vessels during the unloading/loading process. Off-site emissions would result primarily from vehicle traffic to and from the Terminal and from trains operating to and from the Custer Spur. The expected levels of analysis of these project components are described further below.

### **Off-Site Air Quality Impact Assessment**

This analysis will consider potential off-site impacts due to project-related sources. Such reviews typically consider surface vehicle traffic near an operating facility as well as other modes of transportation for facility materials. In this instance, the air quality review will include both vehicular and train transport systems in the project vicinity.

The surface vehicle portion of the review will be based on data produced in the traffic impact analysis. This analysis typically considers congestion at signalized intersections, but review of the preliminary traffic impact assessment suggests PM peak-period effects would be minimal at signalized intersections. This aspect of the air quality evaluation will be more thoroughly considered and may require modeling analysis.

In addition, the potential for air quality impacts resulting from increases in traffic congestion due to train crossings at unsignalized surface street intersections also may require air quality modeling. The focus of all the off-site, vehicle-related modeling will be carbon monoxide and possibly PM<sub>2.5</sub> and diesel particulate matter (DPM).

Ambient concentrations of PM<sub>2.5</sub> and DPM due to emissions from locomotives associated with commodity unit trains will be examined to assess likely increases in concentrations of these air pollutants at off-site receptors along the Custer Spur rail line.

### **On-Site Air Quality Impact Assessment**

On-site operational emissions will be quantified and modeled as part of the air quality review.

#### **5.7.3.3 Emission Calculations**

On-site emissions sources associated with the facility include:

- On-site commodity-handling mobile equipment (i.e., dozers, front-end loaders);
- Locomotive emissions within the Terminal area;
- Vessel emissions while in transit and while at berth;
- Fugitive emissions during commodity transport and transfer operations by automated systems, including rail car dumping (within a shed) and numerous conveyors, all of which would be covered and employ emission controls;
- Fugitive emissions associated with commodity loading into vessel holds; and
- Fugitive emissions associated with commodity storage piles, including those from several stacker/reclaimers forming piles and removing materials from the piles.

Emissions attributable to each source will be estimated using generally acceptable methods and tools reviewed by NWCAA. Emission control options for each source will be evaluated and applied to the emissions inventory estimates. On-site project-related equipment emissions will be estimated using emission factors from the EPA's AP-42 (EPA 1995) and the EPA NONROAD model. On-site fugitive emissions will also be estimated based on AP-42 emission factors for material drops and windblown dust from stockyard piles. Reasonable assumptions regarding the effectiveness of expected emission control measures based on available data and the BACT determinations will be incorporated into the emission estimates.

Based on emission factors derived from BACT determinations, vendor data, and the technical literature, on-site source emissions will be evaluated based on projected short-term and annual throughputs and operating rates. Information regarding the range of vessel types expected to call at the terminal will be used to estimate emissions from ship engines.

It is anticipated that, except for potentially high concentrations of fugitive dust during occasional high-wind events, none of the other emission sources associated with the project would be likely to result in significant air quality impacts, even in the absence of additional mitigation measures. That is, all facility-related emissions are expected to comply with applicable ambient air quality standards, based on the project as currently proposed. Controlling dust from stockpiles during high-wind events may require additional controls, based on the findings of the pending air quality modeling.

#### **5.7.3.4 Air Quality Impact Analysis**

Representative meteorological data for the Cherry Point area will be used in conjunction with the emissions estimates to perform air quality dispersion modeling. The air quality modeling analysis will employ the AERMOD dispersion model to identify off-site concentrations of pollutants generated from the project site. The air quality review will consider all criteria air pollutants and examine model-predicted, project-related ambient air concentrations, and compare these with federal, state, and local ambient air quality standards, focusing on coarse and fine particulate matter (PM<sub>10</sub> and PM<sub>2.5</sub>, respectively) along with NO<sub>2</sub> and SO<sub>2</sub>. When appropriate, project-related concentrations will be added to background air quality values to identify cumulative concentrations. Emissions and concentrations of diesel particulate matter resulting from vessels and trains will also be evaluated.

#### **5.7.4 Proposed Design Features Intended to Reduce Impacts**

The project as proposed includes numerous features intended to reduce or eliminate emissions that would occur in the absence of these control measures. The Terminal design incorporates the following emission control features:

- Rail car unloading would occur inside a covered shed at the unloading station. Air inside the shed would be drawn into a dust control system during unloading, and the air stream would be processed using a baghouse to remove particulate matter. The baghouse ventilation system will maintain a negative air pressure inside the shed to prevent particulate matter emissions from escaping from the opens ends of the shed.
- All conveyor transfer points will be controlled using a combination of passive emission control (PEC) systems or dry fog emitters (as appropriate depending on the commodity). PEC systems prevent dust from escaping transfer chutes by “sliding” the materials from one belt to another instead of dropping it. The chutes are fully enclosed, and these chute enclosures are secondarily contained inside a transfer tower. In some locations with insufficient space to allow passive emission control chutes to be installed, dry fog technology would be employed (as appropriate depending on the commodity) to control particulate matter emissions at transfer points.

The “dry” fog is a sonic-induced mixture of 10 to 15 percent water and 85 to 90 percent air that is sprayed over the commodity riding on the conveyor both before and after transfer points. In this system, the conveyor and transfer points would be completely enclosed to retain the fog, and a transfer tower would provide secondary enclosure around the entire process. The particles in the fog are so tiny that they attract any dust, allowing the dust to agglomerate to the fog particles, which then fall from air. These emission control measures are expected to provide nearly 100 percent control of dust emissions at conveyor transfer points.

- Conveyors on the trestle and wharf would be enclosed to control fugitive dust emissions. All other conveyors, except the stacker/reclaimers, would be covered to minimize fugitive dust emissions.
- Stacking and reclaiming from stockpiles would use appropriate technology to minimize the drop from the stackers to the piles. Similarly, shiploaders would use shaped flow controls to place the commodity as gently as possible into the hold, and the opening would be configured so that the drop of commodities from the shiploader would occur below the combing (opening) of the vessel’s hold.
- The stockyard area would be shielded from winds using wind fencing.

All of these factors will be considered as part of the air quality impact assessment.

## **5.8 LAND USE**

This section describes existing land uses, the compatibility of the proposed project with adjacent land uses, and plans for future development of the project area, as defined by Whatcom County’s Comprehensive Plan and zoning code. Because the project includes a proposed marine terminal

constructed in state tidelands, compatibility with plans for management of tideland resources is also discussed. The main issues of concern for the proposed Terminal project relative to land use are:

- Assuring that construction and operation are compliant with zoning and land-use plans and standards; and
- Assuring construction and operation do not adversely affect appropriate uses of adjacent lands.

### **5.8.1 Affected Environment**

This section describes existing land uses near the proposed Terminal, and the applicable land-use plans for the Terminal site and vicinity.

#### **5.8.1.1 Existing Land Uses**

The project area is currently undeveloped and vegetated with red alder forest, pastures, hayfields, mowed utility corridors, and abandoned fields. Recent land uses have included pasture, hay farming, and firewood and pulpwood harvest. Pastures and hayfields are occasionally tilled and reseeded.

Neighboring properties include the BP Cherry Point Refinery immediately north and west, WDNR school lands, and a large privately held parcel mainly on the south currently used as pasture. The southern extent of the Strait of Georgia forms the south and southwestern boundary. The BNSF Railway's Custer Spur lies in the easternmost portion of the project area and includes the Elliot Rail yard. Utility corridors include a buried petroleum pipeline and a high-power electrical line. Other nearby land uses includes the Lake Terrell State Wildlife Refuge to the east. The closest residential areas in proximity to the project area are located approximately 1.5 miles to the east lying between the project area and the Wildlife Refuge.

Other industrial facilities in the vicinity include the ConocoPhillips' Ferndale Refinery (approximately 2.5 miles to the southeast) and the ALCOA-Intalco Works (aluminum processing; approximately 1 mile to the southeast). The BP Cherry Point refinery was constructed in 1971, the Intalco works in 1966, and the Ferndale refinery in 1954, maintaining an industrial setting in the region for the past 50 years, which is consistent with the proposed Terminal. Each of the industrial facilities includes a pier extending into the Cherry Point reach of the Strait of Georgia. BNSF Railway is proposing improvements along the length of the Custer Spur. Land use adjacent to the existing right-of-way is largely rural, although businesses aligned with the main Cherry Point industries are present as well.

### **5.8.1.2 Whatcom County Comprehensive Plan**

Whatcom County's Comprehensive Plan, first adopted in 1996 and last updated in January 2010, is intended to guide growth in unincorporated areas of Whatcom County for the next 20 years in coordination with the updated master plans of the individual cities. The fundamental purpose of the Comprehensive Plan is to establish a framework of goals, policies, and action items for the more detailed growth planning and implementation actions that will occur in the near future in designated urban growth areas and in the county's rural areas.

Under Whatcom County's 2009 Comprehensive Plan update (Whatcom County 2010a), the project area is designated as part of the Major/Port Industrial UGA, which covers approximately 7,000 acres (Figure 5-25). The subarea plan includes goals and policies aimed at guiding future land-use policies, regulations, and, ultimately, development. All adopted regulations must be consistent with these goals and policies, and thus any development projects found to be consistent with the regulations are by default consistent with the goals and policies. Where development regulations have not been adopted, then development projects must be found to be consistent with the goals and policies themselves.

Most of the goals and policies pertain to how the county will plan and/or develop regulations in the future, or have to do with non-industrial development (e.g., residential). Those intent statements, goals, and policies of the Comprehensive Plan that appear to be pertinent to the Gateway Pacific Terminal project, and a determination of consistency, are shown in Table 5-28.

### **5.8.1.3 Zoning**

As shown on Whatcom County's zoning map, the uplands portion of the project area is designated Heavy Impact Industrial (HII), (Figure 5-26) and governed by Whatcom County Code (WCC) 20.68. However, because the subject property is in the Cherry Point Major Industrial Urban Growth Area, it is also subject to the Cherry Point Industrial District (CPID) regulations (WCC 20.74). These sets of regulations are compatible, with the former containing the use and standards requirements, and the latter acting as an overlay district requiring master planning on large projects.

The Cherry Point HII zone has special characteristics of regional and international significance for the siting of large industrial facilities, including deep water and access to rail transportation. The BP Cherry Point Refinery, ALCOA-Intalco works, and ConocoPhillips Ferndale Refinery together occupy approximately 4,100 acres in Whatcom County's Cherry Point HII zone (Figure 5-25). All of these industries are dependent on water and rail access for moving commodities to and from their facilities.

Whatcom County identified this area for deep-water port industrial development, and the Comprehensive Plan and zoning regulations provide for this type of development (WCC 20.68.010).

Whatcom County Code 20.68.050 (Permitted uses), subsection .059, specifically identifies “Bulk commodity storage facilities, and truck, rail, vessel and pipeline transshipment terminals and facilities” as an outright permitted use.

The proposed Terminal would result in development of an additional 350 industrial acres (of the total Project Area of 1,200 acres) and would be consistent with the HII zoning.

BNSF Railway’s proposed improvements to the Custer Spur fall primarily within area zoned “R” for rural use. The Elliot Yard is located within the HII zone and the Light Impact Industrial (LII) zone. Transportation facilities, including railways, are a permitted use in the Whatcom County Code within both the HII and LII zones.

#### **5.8.1.4 Whatcom County Shoreline Master Program**

The purpose of Washington’s Shoreline Management Act is to manage and protect the shorelines of the state by regulating development in the shoreline area. Its jurisdiction includes the Pacific Ocean shoreline and the shorelines of Puget Sound, the Strait of Juan de Fuca, rivers, and streams and lakes above a certain size. It also regulates “wetlands” associated with these shorelines. The primary responsibility for administering this regulatory program is assigned to local governments. Local governments have done so through the mechanism of shoreline master programs, adopted under rules established by Ecology that establish goals and policies implemented through use regulations. No substantial development is permitted on the state’s shoreline unless a permit is obtained from the local jurisdiction.

The project area is bounded by the Strait of Georgia on the southwest. The portion of the project site that is seaward of the extreme low tide line is considered a shoreline of statewide significance under the state’s Shoreline Management Act of 1971 [RCW 90.58.030(2)(e)(iii)]. A shoreline of statewide significance refers to a specific category of shoreline where certain priority uses are preferred and identified in the statute and in the local shoreline master program for the jurisdiction.

The County’s Shoreline Management Program is codified as WCC Title 23. It designates the shoreline within the project area as part of the Cherry Point Management Area (Figure 5-27). This designation is intended to balance the natural habitat features found in the Cherry Point area with the unique features that make it ideal for water-dependent facilities. The Shoreline Management Program specifically identifies water-dependent industrial facilities as the preferred use in the area, but the area is limited to one additional pier. The proposed Terminal is consistent with the Shoreline Management Program for the development of the project site. Section 2.1.1.2 provides a brief history and explanation of the existing Shoreline Substantial Development Permit for the project.



**WHATCOM COUNTY Title 20 Zoning & Comprehensive Plan Designation**

**COMPREHENSIVE PLAN DESIGNATIONS**

- Incorporated City Limits
- Urban Growth Area
- Urban Growth Area Reserve
- Major/Port Industrial UGA
- Rural
- Small Towns
- Crossroads Commercial
- Resort/Recreational Subdivisions
- Suburban Enclaves
- Transportation Corridors
- Agriculture
- Rural Forestry
- Commercial Forestry
- Mineral Resource Lands
- Public Recreation
- Project Site Boundary

**TITLE 20 ZONING DESIGNATIONS**

**INDUSTRIAL**

- HII** Heavy Impact Industrial
- LII** Light Impact Industrial
- GM** General Manufacturing
- GI** Gateway Industrial
- AO** Airport Operations

**COMMERCIAL**

- GC** General Commercial
- TC** Tourist Commercial
- NC** Neighborhood Commercial
- STC** Small Town Commercial
- RC** Resort Commercial

**URBAN RESIDENTIAL**

- URMX** Urban Residential-Mixed Use
- URMX(10-24)** Urban Residential-Mixed Use 10-24 Units/Acre
- URMX(6-12)** Urban Residential-Mixed Use 6-12 Units/Acre
- URMX(6-10)** Urban Residential-Mixed Use 6-10 Units/Acre
- URM(24)** Urban Residential-Medium Density 24 Units/Acre
- URM(18)** Urban Residential-Medium Density 18 Units/Acre
- URM(12)** Urban Residential-Medium Density 12 Units/Acre
- URM(6)** Urban Residential-Medium Density 6 Units/Acre
- UR(6)** Urban Residential-6 Units/Acre
- UR(4)** Urban Residential-4 Units/Acre
- UR(3)** Urban Residential-3 Units/Acre

**RURAL RESIDENTIAL**

- RR(3)** Rural Residential-3 Units/Acre
- RR(2)** Rural Residential-2 Units/Acre
- RR(1)** Rural Residential-1 Unit/Acre
- RRI** Rural Residential Island
- TZ** Transitional-R5A/RR1

**RURAL**

- R(2)** Rural-1 Unit/2 Acres
- R(5)** Rural-1 Unit/5 Acres
- R(10)** Rural-1 Unit/10 Acres

**RESOURCES**

- AG** Agriculture
- CF** Commercial Forestry
- RF** Rural Forestry
- MRL** Mineral Resource Lands (Overlay Zone)

**OTHER**

- ROS** Recreation Open Space
- EI** Eliza Island

- Zoning Boundary
- Subarea Boundary
- National Forest Boundary
- Water Resource Protection Overlay Zone
- Mineral Resource Lands
- Tranferable Development Rights (TDRs)**  
**TDR Receiving Areas** - All URMX Zones except Bennett Dr.
- TDR Sending Areas** - Lake Whatcom Watershed (same boundary as Lake Whatcom portion of Water Resource Protection Overlay Zone) excluding Sudden Valley

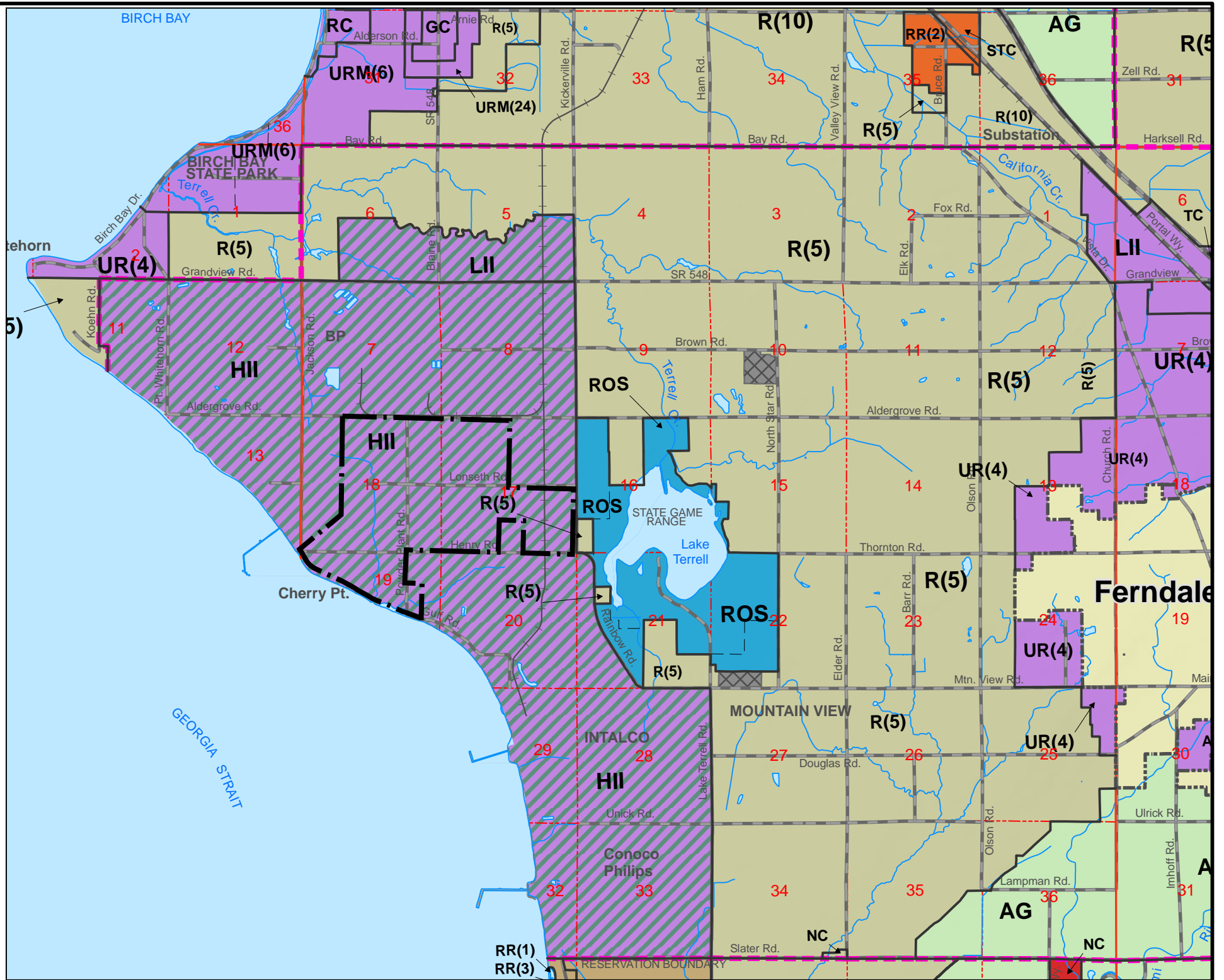
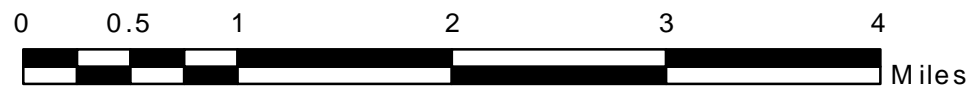
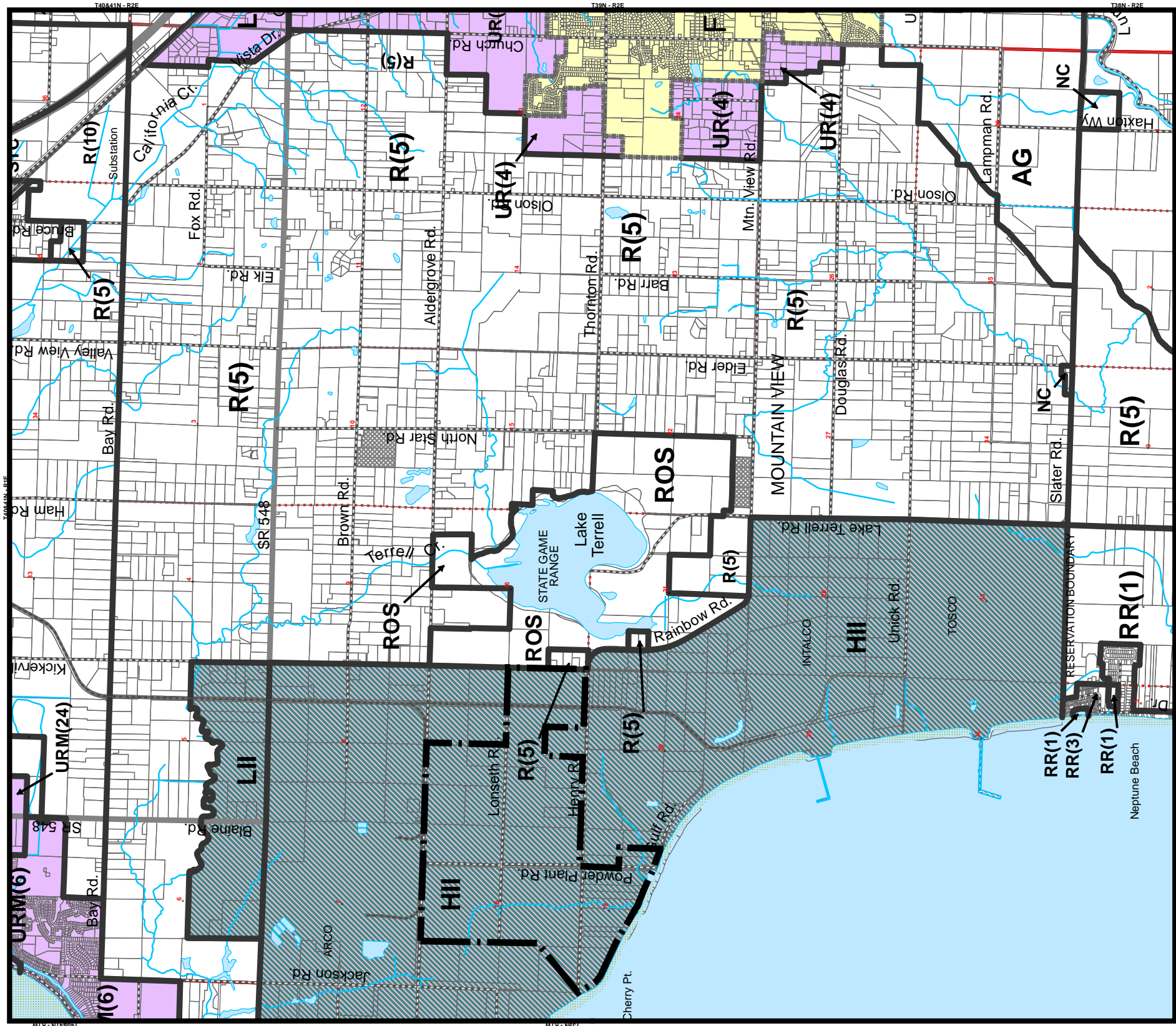

Image Source: Whatcom County GIS Services



 Pacific International Terminals. <small>A Carrix Enterprise</small>	CLIENT:	PACIFIC INTERNATIONAL TERMINALS, INC.	DWN BY:	--	PROJECT:	GATEWAY PACIFIC TERMINAL	DATE:	JANUARY 2011
				CHK'D BY:	--			PROJECT NO.:
			DATUM:		TITLE:	COMPREHENSIVE PLAN MAP	REV. NO.:	1
			PROJECTION:				FIGURE NO.:	5-25
			SCALE:	As Shown				





# WHATCOM COUNTY - Title 20 Zoning Designations



Image Source: Whatcom County GIS Services

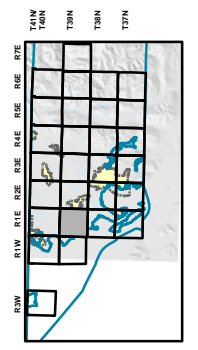
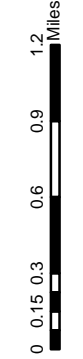

- INDUSTRIAL**
  - HII Heavy Impact Industrial
  - LII Light Impact Industrial
  - GM General Manufacturing
  - GI Gateway Industrial
  - AO Airport Operations
- COMMERCIAL**
  - GC General Commercial
  - TC Tourist Commercial
  - NC Neighborhood Commercial
  - STC Small Town Commercial
  - RC Resort Commercial
- URBAN RESIDENTIAL**
  - URMX Urban Resid. Mixed Use 10-24 Units/Acre
  - URMX(10-24) Urban Resid. Mixed Use 10-24 Units/Acre
  - URMX(6-12) Urban Resid. Mixed Use 6-12 Units/Acre
  - URMX(6-10) Urban Resid. Mixed Use 6-10 Units/Acre
  - URM(24) Urban Resid. Medium Density 24 Units/Acre
  - URM(18) Urban Resid. Medium Density 18 Units/Acre
  - URM(12) Urban Resid. Medium Density 12 Units/Acre
  - URM(6) Urban Resid. Medium Density 6 Units/Acre
  - UR(4) Urban Residential 4 Units/Acre
  - UR(3) Urban Residential 3 Units/Acre
- RURAL RESIDENTIAL**
  - RR(3) Rural Residential 3 Units/Acre
  - RR(2) Rural Residential 2 Units/Acre
  - RR(1) Rural Residential 1 Unit/Acre
  - RR1 Rural Residential Island Transition - R5A/RR1
  - TZ
- INDUSTRIAL**
  - R(2) Rural 1 Unit/2 Acres
  - R(5) Rural 1 Unit/5 Acres
  - R(10) Rural 1 Unit/10 Acres
- RESOURCES**
  - AG Agriculture
  - CF Commercial Forestry
  - RF Rural Forestry
  - MRL Mineral Resource Lands (Overlay Zone)
- OTHER**
  - ROS Recreation Open Space
  - EI Eliza Island
  - PUD Planned Unit Development
- URBAN GROWTH AREA**
  - UGA Urban Growth Area
  - UGA Major Port/Industrial UGA
  - UGA Urban Growth Area Reserve
  - UGA MRL Overlay Zone
- PROVISIONAL REZONES**
  - WTRP Lake Whatcom Water Resource Protection Overlay Zone and TDR Sending Area (Sudden Valley excluded from TDR Sending Area)
  - LSWTRP Lake Samish Water Resource Protection Overlay Zone

## T39N - R1E

Project Site Boundary

Pacific International Terminals.  
A Cairn Enterprise

CLIENT: PACIFIC INTERNATIONAL TERMINALS, INC.

DWN BY: \_\_\_\_\_  
CHK'D BY: \_\_\_\_\_  
DATUM: \_\_\_\_\_  
PROJECTION: \_\_\_\_\_  
SCALE: As Shown

PROJECT: GATEWAY PACIFIC TERMINAL  
TITLE: ZONING MAP

DATE: JANUARY 2011  
PROJECT NO.: 5-91M-15338C-18-01  
REV. NO.: 1  
FIGURE NO.: 5-26



# OFFICIAL SHORELINE MAP - EXHIBIT 3

## Shoreline Area Designations

- Urban
- Urban Resort
- Urban Conservancy
- Shoreline Residential
- Rural
- Resource
- Conservancy
- Natural
- Tribal
- Cherry Pt. Management Area
- Aquatic  
Applies to all areas waterward of OHWM on Shorelines of the State
- Area Designation Breaks
- Urban Growth Areas
- Section Lines
- City Boundaries
- Whatcom County Boundaries
- Project Site Boundary

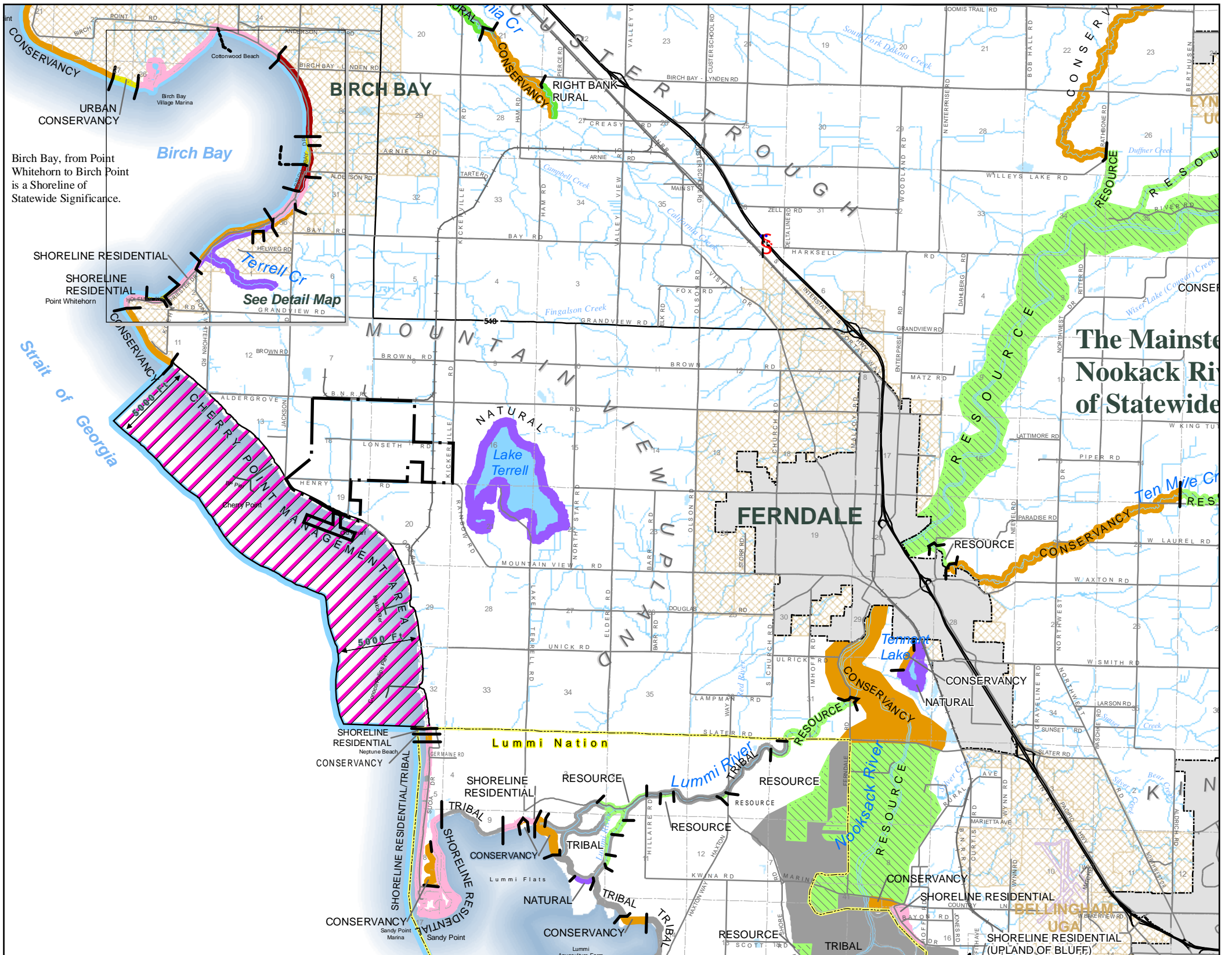
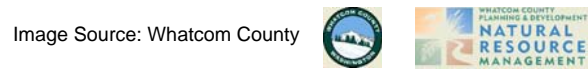
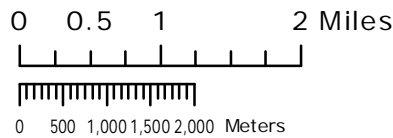

 <b>Pacific International Terminals.</b> <small>A Carrix Enterprise</small>	CLIENT: <b>PACIFIC INTERNATIONAL TERMINALS, INC.</b>	DWN BY: -- CHK'D BY: -- DATUM: PROJECTION: SCALE: As Shown	PROJECT: <b>GATEWAY PACIFIC TERMINAL</b>  TITLE: <b>SHORELINE MANAGEMENT PROGRAM DESIGNATION MAP</b>	DATE: JANUARY 2011 PROJECT NO.: 5-91M-15338C-18-01 REV. NO.: 1 FIGURE NO.: 5-27
	Image Source: Whatcom County			



**Table 5-28 Pertinent Comprehensive Plan Goals and Policies**

<b>Document/ Chapter</b>	<b>Goal</b>	<b>Title</b>	<b>Synopsis</b>	<b>Consistency of Gateway Pacific Terminal with Applicable Policies</b>
<b>Comprehensive Plan</b>				
2		Land Use – Major Industrial Urban Growth Area / Port Industrial	Describes the history and purpose of the Cherry Point UGA, its attributes, and why port development in this area is appropriate and desirable.	Consistent with Intent Statement
	2BB		Regarding maintaining Cherry Point as an unincorporated UGA.	Consistent with Goal and Policies 1 – 10
6		Transportation		
	6Q		Regarding supporting intermodal connections that promote use of air, water, and/or rail freight.	Consistent with Goal and Policies 1 – 3
	6R		Regarding importance of inland transportation systems, including freight rail and intermodal linkages for moving goods.	Consistent with Goal and Policy 1
7		Economic Growth and Environmental Quality		
	7G		Regarding coordinating economic development with environmental, resource, and other comprehensive land use and open space policies and measures to enhance the community's overall quality of life	Consistent with Goal and Policy 6
<b>Cherry Point/Ferndale Subarea Plan</b>				
IV	C.4		Regarding encouraging a balanced and diversified economy; strengthening and stabilize the tax base; accommodating anticipated economic development in an environmentally responsible manner with consideration for public cost, energy availability, land use compatibility, and transportation accessibility.	Consistent with Goal
IV	D.2		Regarding continuing the identification of cultural and natural resources and formulate viable methods to preserve and conserve such resources in recognition of their irreplaceable character.	Consistent with Goal
IV	E.2		Regarding participating in coordination with all agencies to create an environment for the exchange of information and technical assistance.	Consistent with Goal
VI.G		Heavy Impact Industrial	Regarding the purpose of the Heavy Impact Industrial designation	Consistent with Intent Statement and Policies 1.03, 1.05, 1.06

UGA Urban Growth Area

The originally approved permits for the Gateway Pacific Terminal, issued on May 13, 1997, were reviewed through a lengthy public process and found to be consistent with Whatcom County shoreline provisions. This decision was subsequently appealed, and Pacific International Terminals entered into a settlement agreement with the appellants. The original Substantial Development Permit is still in effect, and was reaffirmed by Whatcom County on January 15, 2009.

BNSF Railway's proposed Custer Spur improvements would cross Terrell Creek and California Creek. However, neither is considered a Shoreline of the State in this location. Thus, the rail improvements are outside the jurisdiction of Whatcom County's Shoreline Management Program.

### **5.8.2 Potential Effects on Land Use**

The proposed project would not have any major impacts on land use in the project area. Currently, other than habitat, the property serves minimal use, and the only use that has been approved by Pacific International Terminals is pasture and hay farming by a tenant farmer on approximately 100 acres of the property. Though Terminal development would result in permanent loss of this existing use, the type of development proposed is what has been envisioned for this property and planned for as stated in the County's Comprehensive Plan. The proposed project is consistent with the Comprehensive Plan and Whatcom County's zoning and Shoreline Management designations, which specifically identify water-dependent industries as a preferred use in the area. Additionally, the proposed project is consistent with immediately surrounding industrial land uses.

BNSF Railway's proposed improvements to the Custer Spur would convert approximately 43 acres of land between Ham Road and Brown Road, linear and contiguous to the existing railroad right-of-way, from potentially rural use to transportation land use. The Elliot Yard improvements proposed by BNSF Railway would not have any major impacts on land use, as they would occur within the existing Major/Port Industrial UGA and would be consistent with land uses identified under the existing zoning and Comprehensive Plan designations.

### **5.8.3 Proposed Design Features Intended to Reduce Impacts**

No measures are proposed for impacts to land use, as no adverse impacts would occur.



## 5.9 SOCIOECONOMIC ENVIRONMENT

This section describes the social and economic conditions of the project vicinity, including demographics, income, employment, and public finances, and examines the effects of the proposed action on the socioeconomic environment.

Key issues of concern regarding the project relative to socioeconomic factors include:

- Effects to the local and state economy;
- Effects to commercial fishing and tourism; and
- Effects to public services and infrastructure.

### 5.9.1 Affected Environment

Population centers in Whatcom County include the incorporated cities of Bellingham, Blaine, Everson, Ferndale, Nooksack, and Sumas. Three additional population centers in unincorporated areas within the county include Birch Bay, Cherry Point, and Columbia Valley. The Study Area for the socioeconomic environment includes Whatcom County and the State of Washington.

#### 5.9.1.1 *Population and Demographics*

The estimated population in 2009 for Whatcom County was approximately 200,000 people. The population of Whatcom County grew by 20.1 percent from 2000 to 2009 (Table 5-29), a growth rate that exceeded the statewide growth rate for the same period (13.1 percent).

According to 2009 estimates, Whatcom County had a younger median population age (35.8 years) compared to the State of Washington (36.8 years). In 2009, a large majority of the population in Whatcom County (83.3 percent) classified themselves as being White persons not of Hispanic origin, compared to 74.6 percent of the people in the state as a whole. Approximately 10 percent of the people living in Washington classified themselves as being of Hispanic or Latino origin, compared with approximately 7 percent of the residents of Whatcom County in this same classification. American Indian and Alaska Native persons constituted 3 percent of the population of Whatcom County in 2009 as compared with 1.8 percent in the State of Washington. The percentage of Black persons in Whatcom County (1.1 percent) was lower than the state as a whole (3.9 percent) in 2009.

**Table 5-29 General Population and Demographic Information, Whatcom County and State of Washington**

<b>Social Attribute</b>	<b>Whatcom County</b>	<b>State of Washington</b>
<b>Population</b>		
Population, 2009 estimate	200,434	6,664,195
Population, 2000 Census	166,828	5,894,143
Population, percent change, 2000 to 2009	20.1	13.1
<b>Demographics</b>		
Female persons, percent, 2009	50.6	50.0
Male persons, percent, 2009	49.4	50.0
Median age in years, 2005-2009 estimate	35.8	36.8
Persons under 5 years old, percent, 2009	5.9	6.8
Persons under 18 years old, percent, 2009	20.9	23.6
Persons 65 years old and over, percent, 2009	13.0	12.1
White persons not Hispanic, percent, 2009	83.3	74.6
Persons of Hispanic or Latino origin, percent 2009	7.2	10.3
American Indian and Alaska Native persons, percent 2009	3.0	1.8
Black persons, percent, 2009	1.1	3.9
Foreign born persons, percent, 2000	9.8	10.4
Language other than English spoken at home, percentage 5+, 2000	9.2	14.0
High school graduates, percent of persons age 25+, 2000	87.5	87.1
Bachelor's degree or higher, percent of persons age 25+, 2000	27.2	27.7
<b>Housing</b>		
Housing units, 2009 estimate	88,205	2,813,372
Housing units, 2000 Census	73,893	2,451,075
Housing units, percent change, 2000 to 2009	19.4	14.8
Average household size, 2009 estimate	2.48	2.52

Source: U.S. Census Bureau – State & County QuickFacts, 2010a

Source: U.S. Census Bureau, 2010b, 2005-2009 American Community Survey

Housing construction in Whatcom County kept pace (19.4 percent increase) but lagged slightly with population growth (20.1 percent) from 2000 to 2009. The State of Washington's construction rate for the same period exceeded population growth for the same period (14.8 and 13.1 percent, respectively). Whatcom County and the State of Washington had similar average household size in 2009, at 2.48 and 2.52 persons, respectively.

### **5.9.1.2 Employment, Income, and Economy**

Preliminary employment data for the first quarter of 2010 indicated that the Government sector was the largest employer in the State of Washington (Table 5-30), with approximately 525,000 jobs, followed by the Health Care and Social Assistance (318,147), Retail Trade (296,088), and

**Table 5-30 Employment by Industry, Whatcom County and the State of Washington, First Quarter 2010 (Preliminary)**

Industry Description	Whatcom County			State of Washington		
	Average Employment	Average Weekly Wage	Average Quarterly Wage	Average Employment	Average Weekly Wage	Average Quarterly Wage
Agriculture, Forestry, Fishing and Hunting	2,357	\$453	\$5,886	67,098	\$472	\$6,139
Mining	120	\$899	\$11,687	1,990	\$1,026	\$13,333
Utilities	176	\$1,273	\$16,554	4,800	\$1,482	\$19,267
Construction	4,760	\$904	\$11,746	124,402	\$931	\$12,106
Manufacturing	7,317	\$1,096	\$14,250	250,076	\$1,208	\$15,700
Wholesale Trade	2,573	\$865	\$11,242	115,879	\$1,183	\$15,378
Retail Trade	9,423	\$451	\$5,862	296,088	\$554	\$7,204
Transportation and Warehousing	1,738	\$695	\$9,036	76,622	\$902	\$11,729
Information	1,453	\$789	\$10,259	101,395	\$1,857	\$24,142
Finance and Insurance	1,818	\$1,021	\$13,272	88,590	\$1,476	\$19,194
Real Estate, Rental and Leasing	881	\$538	\$6,991	43,349	\$738	\$9,592
Professional, Scientific and Technical Services	3,054	\$1,008	\$13,105	155,294	\$1,354	\$17,600
Management of Companies and Enterprises	473	\$1,059	\$13,763	31,754	\$1,769	\$23,000
Administrative, Support, Waste Management and Remediation Services	2,846	\$609	\$7,911	121,514	\$775	\$10,075
Educational Services	713	\$379	\$4,925	34,230	\$634	\$8,243
Health Care and Social Assistance	9,486	\$670	\$8,704	318,147	\$797	\$10,367
Arts, Entertainment and Recreation	1,473	\$298	\$3,879	42,519	\$480	\$6,236
Accommodation and Food Services	7,208	\$262	\$3,412	207,721	\$325	\$4,219
Other Services (Except Public Administration)	3,328	\$428	\$5,561	127,912	\$452	\$5,874
Government	14,547	\$843	\$10,960	525,483	\$945	\$12,283
Total All Industries	75,743	\$697	\$9,067	2,734,862	\$899	\$11,685

Source: Washington State Employment Security Department, 2010

Manufacturing (250,076) sectors. A similar employment mix was present for the same period in Whatcom County. The county's major employment sectors included Government (14,547), Health Care and Social Assistance (9,486), Retail Trade (9,423) and Manufacturing (7,317).

As shown in Table 5-30 in the first quarter of 2010, industrial sectors in the State of Washington with the highest average weekly wages included Information Industry workers (\$1,857), Management of Companies and Enterprises (\$1,769), and Utilities (\$1,482). The highest paying sectors in Whatcom County based on weekly average wages for the same period included Utilities (\$1,273), Manufacturing (\$1,096), Management of Companies and Enterprises (\$1,059), and Finance and Insurance (\$1,021).

Household economic characteristics for both Whatcom County and the State of Washington are shown on Table 5-31.

**Table 5-31 Economic Characteristics for Whatcom County and the State of Washington**

<b>Economic Attribute</b>	<b>Whatcom County</b>	<b>State of Washington</b>
Per capita income, 2009	\$25,021	\$29,320
Median family income, 2009	\$63,624	\$68,457
Median household income, 2009	\$47,812	\$56,384
Median value of owner-occupied housing units, 2009	\$288,500	\$277,600
Individuals below poverty level, percent, 2008	15.4	11.8
Unemployment rate, percent, November 2010 (Preliminary)	7.9	9.1

Source(s): U.S. Census Bureau, 2010b – American Community Survey 5-Year Estimates  
 Washington State Employment Security Department, 2010b

In general, 2009 income levels in Whatcom County were lower than the State of Washington. Median family income in Whatcom County equaled \$63,624, while the state’s median family income equaled \$68,457 that year. A larger portion of Whatcom County’s population (15.4 percent) fell below the individual poverty level, compared with the state as a whole (11.8 percent). Preliminary unemployment rate figures (not seasonally adjusted) available for November 2010 indicate that the unemployment rate was lower in Whatcom County (7.9 percent) than for the state overall (9.1 percent).

**5.9.1.3 Public Finances**

Mechanisms readily available to state and/or counties to fund government functions include sales and use taxes, business-related taxes, property tax, revenues through permits, licenses, and fees. No state personal or corporate income taxes exist within the State of Washington.

**Sales and Use Taxes**

As shown in Table 5-32, the State of Washington administers a sales and use tax rate of 6.5 percent. In addition, unincorporated areas of Whatcom County have a 1.4 percent sales and use tax rate, while all other areas in the County have a 2.0 percent tax rate.

**Table 5-32 2010 Combined State and Local Sales and Use Taxes, Locations within Whatcom County**

Location	Local Code	Local Rate	State Rate	Combined State/	
				Local Rate	
Unincorp. Areas	3700	.014	.065	.079	
Unincorp. PTBA*	3737	.020	.065	.085	
Bellingham	3701	.020	.065	.085	
Blaine	3702	.020	.065	.085	
Everson	3703	.020	.065	.085	
Ferndale	3704	.020	.065	.085	
Lynden	3705	.020	.065	.085	
Nooksack	3706	.020	.065	.085	
Sumac	3707	.020	.065	.085	

Source: Washington Department of Revenue, 2010a

\*PTBA = Public Transportation Benefit Area

(Rates presented are percent per dollar spent on sales or use)

### Business-Related Taxes

The State of Washington's Business & Occupation (B&O) tax consists of a tax based on the gross receipts from the value of products, gross proceeds of sale, or gross income of the business. Tax calculations are derived from the gross income from all business activities, including labor and materials. Tax rates for the major B&O Classifications, as determined by the State of Washington and potentially applicable to the construction and operation of the Terminal project include Retail Trade at 0.471 percent; Wholesaling and Manufacturing at 0.484 percent; and Service and Other Activities at 1.8 percent.

The State of Washington also administers a number of excise taxes in addition to the B&O tax, retail sales, use, and property tax. Specifically, the public utility tax consists of a tax on public service businesses, including those that engage in transportation-related activities. The tax is administered in lieu of the B&O tax. Two excise taxes of most relevance related to the project include:

- A tax of 1.926 percent on railroads, railroad car companies, motor transportation, and all other public service businesses; and
- Utility tax; according to Department of Revenue information, most public utility tax money is deposited into the state general fund, with some funding provided to local governments for maintenance of public works facilities (Washington Department of Revenue 2010a).

### Property Taxes

The rate at which property taxes are applied is based on a number of components, including land use and improvements made to a property. According to Whatcom County, levy rates vary for each taxing

district depending upon the budget for each district and any voter-approved special levies and bonds. This levy rate is multiplied per thousand dollars of assessed value.

Whatcom County's 2010 consolidated levy rate in the project area equaled \$8.45235 per thousand dollars of assessed value for Code Area 3020 503F7 C7 NPR (Section 18 of Township 39 North, Range 1 East).

### **Operational Permits, Licenses, Fees, and Assessments**

A number of permits, licenses, and fees would be required for the construction and operation of the project. Those associated with development of the property are addressed in Chapter 2. Other fees or licenses for operation of the Terminal would include wharf and dock fees (based on the gross tonnage of the vessel), state business registration, registration of weighing and measuring devices, assessments on transport of agricultural commodities, and state fuel taxes.

### **Import/Export Duties or Tariffs**

Import and export trades include duties (tariffs) as a result of commerce with other nations by international agreement. Shipments originating from overseas may generate a revenue source in the form of tariffs and/or duties applied to the incoming commodity. According to the US International Trade Commission, US duties vary depending upon the commodity imported into the US. Carbon products (coal, petroleum coke and calcined coke), industrial minerals (lime rock, phosphate rock, potash, sulfur, and salt), aggregates (sand, gravel), wood products (chips, pellets), and ores (concentrate, pelletized ore) typically have no tariff associated with their import to the US. Grain products generally have tariffs ranging, for example, from \$0.001 to \$0.0015 per kilogram (kg) for barley, \$0.0039 to \$0.0058 per kg for oil seeds, and \$0.0035 to \$0.0065 per kg for wheat (US International Trade Commission 2010).

Tariffs or duties on exports applied by other nations vary depending upon the nation and the commodity. Many nations also levy consumption taxes or value added taxes (VAT) in addition to tariffs. For instance, Japan applies a 5 percent consumption tax applied on cost, insurance, and freight (CIF + duty); South Korea applies a VAT of 10 percent on the CIF + duty value; and China applies a consumption tax of 2 to 3 percent on the CIF, as well as a 13-17 percent VAT for most goods (US Department of Commerce 2010).

### **5.9.2 Construction Effects**

Potential economic and social effects resulting from the construction of the project include increased employment and income stemming directly and indirectly from the project. As described in Chapter 4, the proposed project's four-year construction period would take place in two stages commencing in 2013 as shown in Table 5-33. It is also assumed that the estimated construction cost of the Terminal

**Table 5-33 Terminal Construction by Stage**

<b>Construction Stage</b>	<b>Construction Start (Year)</b>	<b>Construction Complete (Year)</b>	<b>Construction Components</b>
1	2013	2014	Stage 1 & 2 wetland mitigation; East Loop infrastructure and utilities; East Loop rail lines (2 tracks in/2 out, & 3 R/D tracks); conveyor system from East Loop to berth; access trestle; wharf; cargo handling equipment; support buildings
2	2015	2016	West Loop infrastructure; utilities; West Loop rail lines (2 tracks in/3 out); A-frame storage shed, bulk storage silos; conveyor to connect to previously constructed system; additional cargo handling equipment (at East Loop and wharf); and East Loop rail lines (2 additional tracks in/2 out). It is also anticipated the second set of tracks along Custer Spur would also be constructed during this Stage

would be approximately \$665 million, of which \$624 million is expected to be local purchase of construction supplies and services (construction cost estimate based on 54 Mtpa throughput) (Martin Associates 2011).

#### **5.9.2.1 Employment and Income**

Jobs created by the project would include the following employment categories:

- Direct employment (jobs directly generated and funded by the project);
- Induced employment (jobs created in the local economy due to purchases made by direct work force expenditures); and
- Indirect employment (jobs created by purchases for goods and services by project operators).

Each of these potential employment categories are described below.

Using the US Bureau of Economic Analysis, Regional Input-Output Modeling System (RIMS) output data for the State of Washington, \$411 million dollars in personal income from construction activity would support a total of approximately 21.8 million hours of employment over a 4-year construction period (Martin Associates 2011). This employment is anticipated to include approximately 9.2 million hours of direct construction employment and 12.5 million hours of induced and indirect employment. (Martin Associates 2011). Assuming a 2,080-hour annual job equivalency, an average of approximately 1,100 direct jobs and 1,500 induced and indirect jobs would be generated from construction of the proposed project over a 4-year construction schedule.

The direct employment classification of new workers would be in the construction industry, and the average wage rate for this job classification in Whatcom County in 2010 was approximately \$47,000 per year (Table 5-30). Similarly, average wage rates for anticipated induced and indirect jobs are \$36,000 per year (Table 5-30). Based on these wage rates, jobs generated as a result of the project construction would average approximately \$106 million in income per year over the course of project construction.

#### **5.9.2.2 Local and Regional Purchases**

Direct construction and capital expenditures for the project are estimated to be approximately \$655 million with \$624 million in local purchases over the approximately 4-year construction period (Martin Associates 2011).

#### **5.9.2.3 Public Finances**

Construction of the Terminal would result in a wide range of potential local and state tax and fee payments. These include state and local sales and use taxes, the State of Washington's B&O tax and/or Public Utility Tax, local property taxes, as well as potential state and local permit, lease, and license fees.

State and local taxes and fees associated with construction-related business revenue and direct, indirect, and induced employment are estimated to total approximately \$71 million over the 4-year construction term (Martin Associates 2011). Additional local and state government revenue would be generated via annual property taxes and any necessary construction-related permit and license fees.

#### **5.9.2.4 Public Services and Infrastructure**

Subject to the available capacity of public services (teachers, police, and fire personnel) and infrastructure (schools, roads and hospitals) at the time of construction, demand for these services would increase in proportion to the influx of new workers into the area.

### **5.9.3 Operational Effects**

Potential economic and social effects resulting from operation of the Terminal include increased employment and income stemming directly and indirectly from the project. Impacts would also include positive and potentially negative impacts on the local, regional, and state economy. It is anticipated the first commodities would be moved through the facility in 2015.

#### **5.9.3.1 Employment**

As described in Section 4.4.3, four operational phases representing the growth in capacity of the Terminal (nominal maximal throughput) are anticipated (Table 4-2). Operation of the Terminal would take place 24 hours a day, 365 days a year, and would require up to 213 full time employees at



maximum capacity. Anticipated staffing levels by shift for each of the four operational phases are shown on Table 4-3.

When the terminal begins operation during Phase 1, it is assumed that 39 employees would operate the day shift and approximately 25 employees would operate the two night shifts, for a total Phase 1 staffing of 89 employees. The total employment for the three shifts would increase to approximately 213 employees at full operational capacity during Phase 4.

Additional direct employment resulting from Terminal operation would include Terminal administrative staff (44 workers), BNSF Railway workers (66), and pilots, tug operators, and other marine service workers (107 workers). Total direct employment related to the terminal would be up to 294 employees during the early period of operation, and would be expected to grow to approximately 430 jobs at full Terminal operating capacity. All these new occupations are attributed to the Transportation industry according to job classification codes and would likely command an average annual wage just over \$36,000 per year for the life of Terminal operation. Collectively, at full capacity operation, this group would earn almost \$15.5 million dollars per year (in 2010 dollars) for the life of the Terminal.

Using model direct, induced, and indirect employment ratio of 4.05 from the RIMS (Martin Associates, 2011), it is anticipated that 293 direct jobs created through Terminal operation would create an additional 1,741 jobs in the local and regional economy. Annual wages and salaries earned in these induced and indirect employment categories may best be represented by the 2010 average weekly wage in Whatcom County of \$697 or \$36,244 per year (Table 5-30). These new employment groups would collectively earn nearly \$63 million dollars a year for the life of the Terminal.

### **5.9.3.2 Local and Regional Purchases**

Economic impacts related to operation of the Terminal include not only direct, induced, and indirect employment and income generated by wages from those jobs, but also local and regional purchases by businesses and individuals directly related to the Gateway Pacific Terminal.

Annual estimated business revenue associated with Terminal operation based on a yearly throughput of 54 Mtpa would total approximately \$1.4 billion, with annual local and regional purchases totaling \$17 million (Martin Associates 2011).

### **5.9.3.3 Public Finances**

Operation of the Terminal would result in a wide range of potential local and state tax and fee payments. These would include state and local sales and use taxes, the State of Washington's B&O

tax and/or Public Utility Tax, local property taxes, as well as potential state and local permit, lease, and license fees, terminal-related wharf or dock fees, and tariffs on commodity throughput.<sup>4</sup>

State and local tax impacts include those payments by firms or individuals either directly employed by, or have jobs supported by, operation of the Terminal. Estimates for state and local tax receipts based on 54 Mtpa throughput equal approximately \$11.2 million annually (Martin Associates 2011). Additional state and local government revenue would be generated via annual property taxes, any required annual permit, lease, or license fees associated with Terminal operation, wharf and dock fees, and tariffs on throughput.

#### **5.9.3.4 Public Services and Infrastructure**

Subject to the available capacity of public services (teachers, police, and fire personnel) and infrastructure (schools, roads, and hospitals) at the time of construction, demand for these services would increase in proportion to the influx of new workers (if any, based on current labor capacity at the time of construction) into the area. As construction of the Terminal is completed and the operational phase commences, fewer workers would be required, potentially reducing demand for services relative to the construction period.

#### **5.9.3.5 Tribal, Commercial Fishing, and Tourism**

Vessel traffic in and out of the Terminal could affect tribal and commercial fishing and tourism. Fisheries in the project vicinity are located in Usual and Accustomed Fishing Grounds for both the Lummi Nation and Nooksack Tribe; the Suquamish, Swinomish, and Tulalip Tribes also may fish in waters surrounding the project area. (Whatcom County 1997).

The southeast Strait of Georgia has been noted as the most important area for the production of Dungeness crab in Puget Sound. Year-round tribal harvest reportedly grew from 13 percent to 53 percent of total commercial harvest between 1990 and 1995. (Whatcom County 1997).

The herring sac-roe fishery is managed jointly by WDFW and four northern Puget Sound herring fishing tribes (Lummi, Nooksack, Swinomish, and Suquamish). The WDFW and the Tribes meet annually to set harvest quotas and other regulations. The area between Point Whitehorn and Sandy Point has historically served as an important fishing ground for the herring fishing fleet. However, by the mid-1990s, the only herring fisheries occurring on or around Cherry Point were the tribal and nontribal spawn-on-kelp (SOK) fisheries and a small sac-roe gillnet fishery conducted by the Nooksack Tribe (Whatcom County 1997). The nontribal fishery was legislatively limited to a small number of SOK permits per year at the time (Whatcom County 1997).

---

<sup>4</sup> More specific information on sources of business revenue and property valuation of the Terminal when operational would be required to analyze fully the public finance implications.

The Strait of Georgia also serves as an important fishing area for five species of Pacific salmon (e.g., chinook, silver, sockeye, pink, and chum). Tribal fishers reportedly use purse seine, gill net, setnet, salmon troll, lampara, and beach seines for their catch. Annual fishing seasons are determined based on the size of salmon returns, though typically a season begins in mid-June and extends to September.

To the extent that the location of project facilities and vessel traffic to and from the Terminal impede tribal or commercial fishing success or tourism, effects on income generated could occur. Potential impacts may include but are not limited to interactions between fishing and/or recreational vessels and marine/tug vessels, degradation in water quality, impacts on spawning fish populations, and shoreline and tidal area impacts.<sup>5</sup> These potential effects, while identified here, are also addressed in Section 5.3 – Marine Resources.

## **5.9.4 Proposed Design Features Intended to Reduce Impacts**

### **5.9.4.1 Public Services and Infrastructure**

In the short-term (first 16 months starting with construction), an influx of workers may increase demand on public service providers and infrastructure, such as schools, emergency management systems, and other county infrastructure. More information is required on both the capacity of the local labor market for the availability of construction workers and for the capacity of public service sectors to accommodate a potential influx of people to the area. With the addition of new jobs and tax revenue generated by the project, increased tax revenues would offset increased demand for these services. However, additional tax revenues typically lag behind initial increase in demand for services. A measure to reduce potential impacts could include advanced tax funding to support public services generated from new local and state tax payments generated by the project.

### **5.9.4.2 Commercial Fishing and Tourism**

Additional technical analysis will be conducted to assess potential effects on commercial and tribal fisheries. Mitigation measures considered in the 1997 EIS related to the Shoreline Development Permit included:

- Schedule construction to avoid herring spawning activities (limit construction to spring).
- Assign approach and departure corridors for commercial traffic to minimize potential conflict with commercial and tribal herring fisheries.

---

<sup>5</sup> These topics were addressed in previous studies (Gateway Pacific Terminal Final EIS 1997). Additional information should be collected to evaluate any subsequent changes to these resources since that time to accurately forecast potential project impacts.

## 5.10 ENVIRONMENTAL JUSTICE

On February 11, 1994, President Clinton issued Executive Order 12898, Federal Actions to Address Environmental Justice in Minority and Low-Income Populations. The purpose of the order is:

- to avoid the potential disproportionate placement of adverse environmental, economic, social, or health effects from federal actions and policies on minority and low-income populations, including Indian Tribes.

### 5.10.1 Affected Environment

The first step in analyzing this issue is to identify minority and low-income populations that would be affected by implementation of the proposed action. Demographic information on ethnicity, race, and economic status is examined in this section as the baseline against which potential effects can be identified and analyzed. The Study Area related to environmental justice issues includes Whatcom County and the State of Washington, including specific consideration of two Indian Tribes with reservation lands located in Whatcom County: the Lummi Nation and the Nooksack Tribe.

#### 5.10.1.1 Identification of Minority and Low Income Populations

The CEQ identifies groups of people as environmental justice populations when either (1) the minority or low-income population of the affected area exceeds 50 percent or (2) the minority or low-income population percentage in the affected area is meaningfully greater than the minority population percentage in the general population or appropriate unit of geographical analysis (Council on Environmental Quality 1997). In order to be classified as *meaningfully greater*, a formula describing the environmental justice threshold as being 10 percent above the State of Washington's rate is applied to local minority and low-income rates per the CEQ guidance. For purposes of this section, minority and low-income populations are defined as follows:

- *Minority populations* are persons of Hispanic or Latino origin of any race, Blacks or African Americans, American Indians or Alaska Natives, Asians, and Native Hawaiian and other Pacific Islanders.
- *Low-income populations* are persons living below the poverty level. The US Census estimates that the poverty-weighted average threshold for a family of four in the United States equaled \$21,954 and \$10,956 for an unrelated individual in 2009 (US Census Bureau 2010c).

#### 5.10.1.2 Minority Populations

As shown in Section 5.9.1.1 (Table 5-29), the American Indian and Alaska Native population in Whatcom County totaled 3.0 percent of total population in 2009 as compared to 1.8 percent for the State of Washington. This 1.2 percent disparity, on a countywide level, is less than the 10 percent difference requirement to establish an Environmental Justice population based on minority

populations. Regardless, the Lummi Nation requests that *Environmental Justice* analyses be conducted for any project that may have impacts within the Lummi Reservation, Usual and Accustomed Area, or ceded area (Meyer Resources 2004).

### **5.10.1.3 Low Income Populations**

As shown in Section 5.9, Table 5-31, the estimated number of persons in 2008 below the poverty level threshold in Whatcom County totaled 15.4 percent, as compared to 11.8 percent in the State of Washington. This 3.6 percent disparity, on a countywide level, is less than the 10 percent difference requirement to establish an Environmental Justice based on the low income criteria.

### **5.10.1.4 Whatcom County Tribal Populations**

Tribal populations specifically located within Whatcom County warrant further consideration given their proximity to the project area and specific cultural and economic relevance of the Cherry Point area to both tribes. Comment letters presented within the 1997 Gateway Pacific Terminal Final EIS (Whatcom County 1997) state that the project area is located within the historic site of the Lummi Nation called Xwe' Chiexen (Cherry Point), and several registered and unregistered areas of cultural significance exist within the project area. In addition, the Treaty of Point Elliott of 1855 provides the Lummi with primary fishing rights for the waters surrounding Xwe' Chiexen. The Nooksack are also signatories under this treaty and have stated that they use the project area for economic (salmon) and spiritual/cultural uses (including crabbing, and clam digging).

### **Lummi and Nooksack Populations**

While the project area excludes tribally owned lands, the Lummi Reservation is located within a few miles to the south and contains 12,500 acres of mainland and 7,000 acres of tidelands along the 5-mile Lummi Peninsula. Lummi Bay lies to the west and Bellingham Bay to the east. In 2008, approximately 4,200 tribal members were enrolled in the Lummi Nation with 2,400 living on the reservation itself (Lummi Natural Resources Department 2008). According to 2000 Census data, the population of the Lummi Reservation totaled 4,193 (Table 5-34).

The Nooksack Tribe, also located in Whatcom County, is located 17 miles east of Bellingham in Deming, Washington, with self-reported enrollment of approximately 2,000 people. According to 2000 Census figures, the population of the Nooksack Reservation and off-reservation trust lands totaled 547 (Table 5-34).

Table 5-34 summarizes a range of available socioeconomic statistics derived from the 2000 Census. In general, the Nooksack Reservation displayed substantially different demographic and economic characteristics than that of the Lummi or Whatcom County as a whole. For instance, while median

**Table 5-34 Socioeconomic Characteristics of the Lummi and Nooksack Reservations**

<b>Selected Socioeconomic Attributes</b>	<b>Lummi Reservation</b>	<b>Nooksack Reservation</b>	<b>Whatcom County</b>
Total population, 2000	4,193	547	166,814
Median age, 2000	35.2	21.9	34.0
Average household size, 2000	2.9	4.0	2.51
Median age, 2000	35.2	21.9	34.0
Per capita income, 1999	\$17,669	\$10,515	\$20,025
Median family income, 1999	\$40,319	\$28,281	\$49,325
Median household income, 1999	\$37,014	\$28,515	\$40,005
Median value of owner-occupied housing units, 2000	\$147,400	\$82,500	\$155,700
Individuals below poverty level, percent, 1999	18	29	14.2

US 2000 Census, SF1 and SF3

age within the Lummi Reservation was similar to that of Whatcom County (35.2 years and 34 years respectively); median age within the Nooksack Reservation was only 21.9 years in 2000.

Per capita income levels for both the Lummi and Nooksack Reservations are modest; median per capita income in 2000 was \$17,669 for members of the Lummi Nation and \$10,515 for members of the Nooksack Tribe. Twenty-nine percent of individuals within the Nooksack Reservation were below poverty level, versus 18 percent within the Lummi Reservation in 2000. For the period, the poverty level difference between Whatcom County and the Nooksack Reservation exceeded 10 percent, establishing the Nooksack Reservation inhabitants as an Environmental Justice population based on income criteria in 2000.<sup>6</sup>

**Tribal Use of Coastal Resources**

The Lummi, located directly south of the project area, have always been strongly associated with the ocean and have traditionally relied on seafood as a major component of their diet. The Lummi Nation is reportedly the largest fishing tribe in Puget Sound. However, declines in the regional salmon fishery have dramatically altered the tribal dependence on salmon fishing as an income generating activity since the mid 1980s. Specifically, the average Lummi fisherman, comprising approximately 30 percent of the tribal workforce at the time, earned \$22,796 from fishing in 1985. Income from commercial fishing fell to \$5,555 by 1993. The annual reported value of the Lummi Nation’s fishery totaled over \$11 million in 1985, but declined to \$5 million by 2001 (Lummi Natural Resources Council 2008).

The Lummi Natural Resources Council reported that the Lummi Indian Business Council commissioned a survey of adult tribal members in 2003. Approximately 28 percent of adult tribal members were unemployed, with up to 14 percent more underemployed at the time. This compares to

<sup>6</sup> More information (as may be available from the 2010 Census) would be required for a current evaluation of these populations on the basis of income to determine current conditions.

an average 6.8 percent unemployment rate for Whatcom County that same year (Bureau of Labor Statistics 2011). According to the Lummi Natural Resources Council, the declining fishery was specifically identified as a factor for this difference. Additional information would be required to establish the Lummi Nation as an Environmental Justice population based on income<sup>7</sup>.

### 5.10.2 Effects

Potential environmental justice effects include potential economic, environmental, and social impacts to the Lummi and Nooksack tribal members in particular, stemming directly or indirectly from construction and operation of the project.

As discussed above, the project area is located within a Lummi Nation historic site called Xwe' Chiexen and the Lummi specifically identify themselves as holding primary fishing rights in coastal waters surrounding the project under the Treaty of Point Elliott of 1855. The Nooksack are also signatories under this treaty and have stated that their economic and spiritual/cultural use of the vicinity would be impacted from a project at Cherry Point. As such, any activities that have the potential to impact fisheries and marine resources could potentially affect the Lummi and Nooksack, and potentially other Tribes with treaty fishing rights in the area, disproportionately.<sup>8</sup> These potential effects, while identified here, are also addressed in Section 5.3 – Marine Resources.

Government to government consultation, as directed by Section 106 of the NHPA, has been underway since 2009. The USACE has sent project description letters to affected Native American Tribes, including the Lummi Nation and Nooksack Tribe; however, no specific information has been made available regarding tribal responses to date. As such, previous tribal concerns as outlined in the Gateway Pacific Terminal Final EIS (1997) will be utilized as a proxy for current conditions.

Previously identified tribal concerns related to expansion of a marine terminal at Cherry Point include potential impacts due to an increase in vessel traffic and associated increase in fuel and other material handling, direct damage to fishing vessels and gear from interactions with commercial vessels, potential degradation of water quality and fishery habitat from construction and operation of a facility, potential damage to tribal tidelands by interruption of sediment transport, and direct permanent loss of fishing opportunities in and around the project area (Whatcom County 1997).

As discussed, concerns outlined above were identified in conjunction with the project considered in 1997. The proposed project being considered at this time would include throughput of up to 54 Mtpa

---

<sup>7</sup> More information (as may be available from the 2010 Census) would be required for a current evaluation of these populations on the basis of income to determine current conditions.

<sup>8</sup> These topics were addressed in previous studies (Gateway Pacific Terminal Final EIS 1997). Additional information should be collected to evaluate any subsequent changes to these resources since that time to accurately forecast potential project impacts.

as compared to throughput of approximately 8.2 Mtpa as considered then. Project concerns in 1997 were largely related to impacts due to increased marine traffic and infrastructure development. It is likely that tribal concerns would be similar under the current Proposed Action.

Additional information is needed to estimate current income levels for potentially affected populations and determine whether either the Nooksack Tribe or Lummi Nation would be currently considered Environmental Justice Populations.

Both the Lummi Nation and the Nooksack Tribe have requested more complete studies be commissioned in advance of any project approvals to understand more fully the associated risks and potential impacts to the marine environment and tribal fishing communities.

Mitigation measures in the 1997 Gateway Pacific Terminal Final EIS remain relevant in the absence of new data on the current state of the fishing industry and the Tribes dependence on it. See Section 5.9.4.2 for these mitigation measures.

Continued tribal consultation with the Lummi and Nooksack, as well as other Tribes with treaty rights near the project area (potentially the Suquamish, Swinomish, and Tulalip Tribes) should be important components of any impact-reduction strategy.

### **5.10.3 Proposed Design Features Intended to Reduce Impacts**

The current Environmental Justice status of Tribal populations based on income remains to be determined. Additional information on these populations, when available, will require review of potentially significant impacts and impact-reduction strategies with respect to qualifying populations.

## **5.11 PARKS AND RECREATIONAL FACILITIES**

This section describes the existing parks and recreational facilities of the subject and surrounding properties and potential environmental impacts thereon. Several state and county parks are identified along with an assessment of the impacts associated with the potential increase in users of those parks due to employees of the Terminal. Issues of concern for park and recreational facilities and uses are:

- Prevention of adverse impacts to park and recreation facilities and uses as a result of construction and operation of the Terminal facility.



### **5.11.1 Affected Environment**

This section describes parks and recreational facilities near the proposed Terminal and presents an assessment of potential impact of Terminal development on those resources. Parks and other recreational facilities near the proposed Terminal are shown on Figure 5-28.

#### **5.11.1.1 Department of Natural Resources School Lands**

One parcel of land adjacent to the east side of the project property is owned by WDNR. This parcel of land is held in trust by the WDNR for the purpose of earning income to fund schools in Washington State. The project does not cross or affect this property in any way and does not impede the ability of the property to earn income for the State.

#### **5.11.1.2 Lake Terrell Wildlife Area**

Lake Terrell Wildlife Area covers 1,500 acres and is managed by WDFW. The Lake Terrell Wildlife Area is located approximately 10 miles northwest of Bellingham, 5 miles west of Ferndale, and a little less than 1 mile east of the eastern boundary of the project area (Figure 5-28). The man-made Lake Terrell is 500 acres in size, stocked with fish, and known for passive recreation, including bird watching. The shallow lake drains north into Terrell Creek. Approximately 55 acres in the wildlife area are farmed to produce winter forage for migrating waterfowl and other wildlife. Canada geese, trumpeter and tundra swans, pen-raised pheasants (released for hunting), and ducks frequent the area. Boat launches, duck blinds, and other amenities are available for use at the wildlife area.

#### **5.11.1.3 Birch Bay State Park**

Birch Bay State Park covers 194 acres and is located approximately 2 miles north-northwest of the Gateway Pacific Terminal site, just north of the Cherry Point Aquatic Reserve boundary. The park has 8,255 feet of saltwater shoreline on Birch Bay and 14,923 feet of freshwater shoreline on Terrell Creek. Camping is permitted at the park and it is one of the largest recreational shellfish areas in the State (WDNR 2010).

#### **5.11.1.4 Whatcom County Parks**

Point Whitehorn Marine Reserve is located approximately 2 miles northwest of the Gateway Pacific Terminal site. The reserve was opened by Whatcom County in 2009, and includes 54 acres of forest, bluff, beach, and interpretive trails. Uses within the reserve are restricted primarily to passive activities and camping, fires, and pets are not allowed (Whatcom County 2007).

### **5.11.1.5 Public Access to the Project Area's Beach**

Public access is allowed currently along the shoreline within the project area, including the beach area adjacent to Gulf Road. Recreational uses include fishing, picnicking, and other passive activities. No public access is allowed along the beach beneath the BP pier just northwest of the project area.

Under the 1999 Settlement Agreement, Pacific International Terminals agreed to convey the saltwater marsh and adjacent lands located on the southwest corner of the property to Whatcom County for park and conservations purposes and to grant, by way of an easement or license, public access to a portion of the property to replace the lost beach access.

## **5.11.2 Potential Effects on Parks and Recreational Facilities**

### **5.11.2.1 Construction Effects**

The proposed project would have no impacts to parks and recreational facilities, because construction of the project would only contribute minor numbers of users to the facilities and would not displace any existing parklands. Use of parks and recreational facilities could increase through an influx of construction employees coming to the area. Based on the anticipated number of construction employees required for the Terminal (see Section 5.9 for more information), and the 250,000 estimated users of Whatcom County parks in 2010, construction employees would make up only a small fraction (approximately 0.7 percent) of the total users (Whatcom County Parks and Recreation Department 2008).

### **5.11.2.2 Operation Effects**

Operation of the proposed project would have no direct effects to parks and recreational facilities. The proposed project is located far enough away from parks and recreational facilities in the vicinity that it would have no impact on their continued ability to operate.

Approximately 213 people would be employed at full Terminal buildout. If all employees used the local County Parks, this would contribute approximately 0.09 percent to Whatcom County's average number of annual park users (Whatcom County Parks and Recreation Department 2008).

Access to the beach from Gulf Road south would not change with Terminal development. However, for security reasons, no access would be allowed near or under the trestle. No physical barrier would be constructed, but the beach area would be posted as private land and security cameras would monitor the area. This would effectively close beach access from the trestle north to BP's pier.

## **5.11.3 Proposed Design Features Intended to Reduce Impacts**

Under the 1999 Settlement Agreement, Pacific International Terminals agreed to convey the saltwater marsh and adjacent lands located on the southwest corner of the property to Whatcom County for

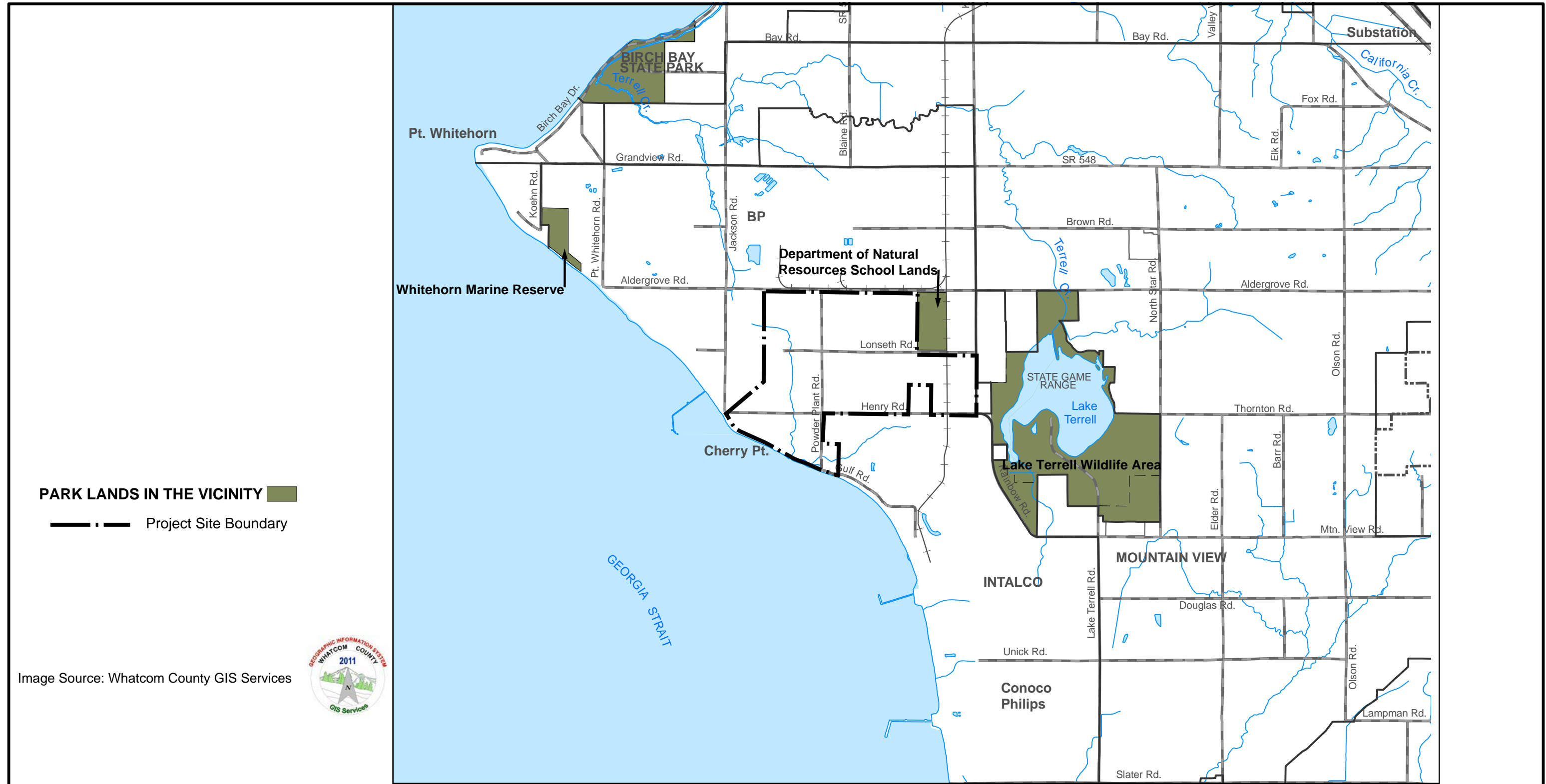

 <b>Pacific International Terminals.</b> <small>A Carrix Enterprise</small>	CLIENT: <b>PACIFIC INTERNATIONAL TERMINALS, INC.</b>	DWN BY: -- CHK'D BY: -- DATUM: PROJECTION: SCALE: <b>As Shown</b>	PROJECT: <b>GATEWAY PACIFIC TERMINAL</b>	DATE: JANUARY 2011
			TITLE: <b>MAP OF PARK LANDS IN THE VICINITY</b>	PROJECT NO.: 5-91M-15338C-18-01 REV. NO.: 1 FIGURE NO.: 5-28



park and conservations purposes, and to grant, by way of an easement or license, public access to a portion of the property to replace the lost beach access.

## **5.12 PUBLIC SERVICES**

This section describes the existing public services, including police, fire, and emergency medical services, serving the project area and vicinity. A discussion of the potential impacts to these services is also included.

Key issues regarding public services include:

- Would the proposed terminal would receive public services within established standards and response times; and,
- Would operation of the proposed Terminal result in an unacceptable impact on services to other existing public service users.

### **5.12.1 Affected Environment**

#### **5.12.1.1 Police**

The Terminal would have full-time security personnel responsible as first responders for safety and site security. Video surveillance cameras throughout the project area would support security staff.

When needed, police services would be provided to the Terminal by the Whatcom County Sheriff. The Sheriff's Office also maintains a Division of Emergency Management that handles various aspects of emergency/disaster mitigation, planning, response, and recovery for the community. This Division partners with other emergency responders, community volunteers, and other individuals and groups for training, education, plan development, and team building. It is anticipated that the Sheriff's Office Division of Emergency Management would partner with Pacific International Terminals in emergency planning and mitigation.

#### **5.12.1.2 Fire and Emergency Medical Services**

Terminal security staff would include employees fully trained in specific emergency procedures. These emergency personnel would be trained as first responders for fire and other emergency response scenarios, including medical emergencies.

Gateway Pacific Terminal is located within Fire District No. 7 based in the city of Ferndale. Five of the district's stations could respond to calls from the Terminal. These stations are located near the following intersections:

- Brown and Kickerville Roads;

- Grandview and Koene Roads;
- Northwest and Smith Roads;
- Grandview and Enterprise Roads; and
- Washington Avenue and 3rd Street in Ferndale.

Fire District No. 7 has approximately 20 full-time career responders and 40 volunteer firefighters. The first two stations that would respond to calls to the Terminal would be volunteer stations, with the next two staffed stations.

Fire District No. 7 services 75 square miles with a population of approximately 22,000 people. Fire District No. 7 does not typically provide first response services to the existing industries in the area (BP, Alcoa, ConocoPhillips), as these industries maintain their own fire teams on site (Hoffman 2011). The District does provide backup and support service to all the industries in Cherry Point, including the three major industrial sites. Service needs for these three industries are similar to what could be required for the Gateway Pacific Terminal project.

#### **5.12.1.3 Emergency Medical Services**

The nearest emergency medical services to the project area are located at St. Joseph Hospital in Bellingham. St. Joseph's is a full service hospital with emergency facilities. St. Joseph Hospital is approximately 17 miles from the project area.

#### **5.12.2 Potential Effects on Public Services**

Effects from the proposed project include a potential increase in demand on fire, police, and emergency medical services. While the Terminal would have employees fully trained in specific procedures as first responders for fire and other emergency response scenarios, including medical, the local services would provide backup.

As stated, the Terminal would have full-time security that would be supplemented by surveillance using cameras. Importantly, no access to the Terminal area would be allowed for the general public, so the public area patrolled by the County Sheriff would be reduced.

The Sheriff's Office and St. Joseph's Hospital are equipped to provide services to a large geographic area with a mix of residential, commercial, and industrial uses. The addition of the Gateway Pacific Terminal and its employees would create a slight increase in the demand for services but this is not anticipated to affect services negatively.

The Terminal would not rely solely on Fire District No. 7 to provide emergency fire services. However, it is possible that the District would not have the necessary resources to provide backup for the Terminal safely during the initial commencement of operations (Hoffman 2011).

### **5.12.3 Proposed Design Features Intended to Reduce Impacts to Public Services**

Additional tax revenue of approximately \$11 million annually generated by the Terminal would go to the state and local jurisdictions (see Section 5.9 for more information) and could be used to offset increases in demand for fire and emergency services. However, a lag time between when the tax revenues could be directed to the services and when services would be needed is anticipated. Fire District No. 7 anticipates there would be an 18 to 24 month delay due to funding cycles before fire services would be expanded (Hoffman 2011).

## **5.13 UTILITIES**

This section describes the existing utilities serving the subject and surrounding properties and potential environmental impacts thereon. Issues regarding utility services include:

- Ensuring the project would receive utility services within established standards and capacities;
- Ensuring the project would not result in an unacceptable adverse impact on utility services to other existing utility users.

### **5.13.1 Affected Environment**

#### **5.13.1.1 Electric Power**

Electrical power is anticipated to be supplied by the Whatcom County Public Utility District (PUD) Number 1. The PUD supplies water and power to the industrial facilities at Cherry Point and has two electrical substations in the project vicinity. The PUD has a power purchase agreement with Bonneville Power Administration (BPA) and currently supplies an average of 27 megawatts per year to the three major industries in Cherry Point. A BPA transmission line, as well as other electrical lines serving the BP Refinery and other industries, runs through the project area. Thus, electric supply is available within the project area and no new power lines would be needed to supply the Terminal.

Power to the Terminal would be supplied to the Terminal's main substation, which is planned to be located at the northeast portion of the project area. A single connection to the PUD supply is envisioned and power to all other portions of the Terminal would be routed from the Terminal's main substation.

### **5.13.1.2 Water**

The PUD supplies approximately 17 million gallons a day of industrial water to other industries located at Cherry Point and holds rights to 53 million gallons a day. Pacific International Terminals has contract capacity with the PUD for 5.33 million gallons a day of industrial water. Industrial water supply to the project area would be from a new 12-inch underground pipe connected at the existing industrial water main line (24-inch diameter) located at Aldergrove Road, or from the intertie pipeline (14-inch diameter) at Kickerville Road. The water supply is anticipated to be sufficient for all Terminal operations including dust suppression. It is also anticipated to be sufficient for fire suppression and safety.

Potable water would be provided from treatment of industrial water with a reverse-osmosis treatment system.

### **5.13.1.3 Sewer**

Sanitary sewage on the site would be processed in a packaged treatment plant and discharged to a septic field adjacent to the office buildings. For the washroom facility on the wharf, the sanitary sewage would be treated onsite and trucked off site.

### **5.13.1.4 Natural Gas**

The Gateway Pacific Terminal would not use natural gas.

### **5.13.1.5 Telecommunications**

Landline telephone services are provided by Qwest and Verizon in the project vicinity; cable television services are provided by Comcast; internet services are provided primarily through Comcast and Verizon; and cellular telephone services are provided through a wide range of providers.

Excluding proprietary information for some of the service providers, the availability of services is high and due to their nature, any supply shortages are easily rectified (City of Ferndale 2007).

## **5.13.2 Potential Effects on Utilities**

### **5.13.2.1 Electric Power**

Effects on electric power would be an increased demand for services. Existing capacity appears to be sufficient for the Terminal and is not anticipated to affect utility providers or their other customers negatively.



### **5.13.2.2 Water**

Effects on water would be an increased demand for services. Existing capacity appears to be sufficient for the Terminal and is not anticipated to affect utility providers or their other customers negatively.

### **5.13.2.3 Sewer**

Sanitary sewage would be treated and handled on site and would not affect utility providers in the area.

### **5.13.2.4 Telecommunications**

Effects on telecommunications would be an increased demand for services. Capacity appears to be able to be added as needed by service providers and is not anticipated to negatively affect them or their other customers.

## **5.13.3 Proposed Design Features Intended to Reduce Impacts**

No design features to reduce impacts are proposed for the use of utilities by the Gateway Pacific Terminal project.

## **5.14 RELATIONSHIP TO OTHER PLANS AND POLICIES**

This section describes the existing federal, state, and local plans and policies pertinent to the project area and surrounding properties. An overview of the plans is provided, as well as a discussion of whether the project is consistent with each of these plans.

The primary focus is to confirm that construction and operation of the Terminal supports existing federal, state, and local plans and policies. If this is not the case, then a discussion of why it is not the case is provided.

### **5.14.1 Affected Environment**

#### **5.14.1.1 Federal Policies**

##### **National Export Initiative**

In response to the recent downturn in the economy, President Obama issued the National Export Initiative on March 11, 2010, to facilitate job creation through increased exporting. Through active participation in international markets, the Administration has a goal of doubling the country's exports within the next five years (Office of the President 2010). The Gateway Pacific Terminal project would contribute to meeting the Administration's goal by exporting coal, potash, and other commodities. The Terminal would create many jobs, as described further in Section 5.9.

## **National Security Policy**

In May 2010, the Obama Administration issued the National Security Policy addressing multiple ways in which the US could renew its role as a world leader and enhance safety and security for the Nation. The National Security Policy views cultivation of strengths and influence in the global market as one of the key ways in which this leadership can be obtained. Specific strengths identified included economic competitiveness, engagement in a globally growing economy, seeking out mutual economic interests with other nations, and maintaining existing economic relationships around the world. The proposed Terminal is consistent with and supports the National Security Policy by creating economic relationships with other countries through the export of commodities.

### **5.14.1.2 State Policies**

#### **Governor's Export Policy**

Governor Christine Gregoire issued the Washington State Export Policy on June 22, 2010, to complement the National Export Initiative. Governor Gregoire committed Washington State resources to partnering with the US Department of Commerce to achieve President Obama's goal of doubling exports by the year 2015. Washington State has strong abilities as an exporter and can leverage these existing strengths to further increase exports and the number of jobs that are tied to those exports. Washington currently has the highest per capita export rate in the US and 4 percent of companies export compared with a national average of 1 percent. One out of every three jobs are tied either directly or indirectly to trade in the State. Through a combination of strengthening relationships with overseas partners and engaging with the federal government in infrastructure investments, Washington State would increase its role in exporting. Specifically, the Governor would like to see \$600 million in new exports and the number of companies exporting increase by 30 percent (Office of the Governor 2010).

The proposed Terminal is consistent with and supports the Governor's Export Policy in the same way it supports the National Export Policy, by increasing exports to other nations and increasing jobs locally.

#### **Cherry Point State Aquatic Reserve**

The WDNR finalized the Cherry Point Aquatic Reserve Management Plan in 2010. The Plan identifies natural resources existing within the boundaries of the reserve, proposed uses, potential risks, and management actions to regulate those uses and protect resources. Development of the Aquatic Reserve Management Plan began in 2007 when WDNR brought together a group of stakeholders, called the Cherry Point Workgroup, to assist with managing the area. The Workgroup gathered technical information and provided recommendations for managing the approximate 227 acres of tidelands. Cherry Point is viewed as a unique environment to balance multiple features, including

natural habitats and deep-water access for industrial use. The management goal is to balance potentially competing uses and emphasize environmental protection.

The reserve was established in 2000 by WDNR with state-owned lands and an additional 69 acres of privately owned lands. The boundary of the Reserve extends 5,000 feet beyond the marine shoreline to include all tidelands and marine area to the depth of -70-feet MLLW (Figure 5-29). The reserve faces a number of threats, including:

- shoreline modifications, such as overwater structures, loss of riparian vegetation, armoring, and derelict gear;
- pollution from groundwater contamination, stormwater runoff, point discharges, and air deposition;
- disturbance from recreation;
- artificial light and excessive intermittent sound;
- vessel traffic and oil spills;
- invasive species; and
- habitat impacts due to climate change.

WDNR identified the four existing industrial uses within the Reserve and identified the proposed use for the Gateway Pacific Terminal project. Existing uses are the industrial piers at BP, Intalco, and ConocoPhillips, and the outfall for the Birch Bay Water and Sewer District. The Aquatic Reserve Management Plan discusses specific requirements for modifications or extensions to use authorizations for these existing users. The Aquatic Reserve Management Plan gives specific reference to the new trestle and wharf for the Gateway Pacific Terminal project:

the additional new pier must meet the requirements of this Management Plan, serve the objectives of the Reserve, meet all regulatory requirements, and conform to the terms and conditions of the 1999 Settlement Agreement. (WDNR 2010, p. 51)

The 1999 Settlement Agreement provided a number of conditions for Terminal development and operations. In addition, the Aquatic Reserve Management Plan stated that the Gateway Pacific Terminal would need to meet the following conditions:

- Identify impacts to salmon and herring due to artificial light and noise and incorporate findings into an operations plan that minimizes impacts;
- Design structures to avoid disruption to herring migration patterns;

- Design the trestle and wharf to minimize wave and light shading; and
- Complete vessel traffic studies and evaluate traffic management needs.

The Aquatic Reserve Management Plan identifies five goals to promote desired future conditions of the Reserve:

1. identify, protect, restore, and enhance aquatic nearshore and subtidal ecosystems;
2. improve and protect water quality habitat;
3. protect and help recover indicator fish and wildlife species and habitats;
4. facilitate stewardship of habitats and species; and
5. identify, respect, and protect archaeological, cultural, and historical resources.

To address potential risks to the Reserve and seek to meet goals and objectives, the Aquatic Reserve Management Plan identifies specific management actions grouped in the following categories: protection and conservation; enhancement and restoration; outreach and education; monitoring, data collection, and research; allowed uses; and prohibited uses.

Pacific International Terminals will collaborate with WDNR and other agencies to help achieve specific goals that:

- Protect existing native vegetation on the bluff;
- Provide public beach access near Gulf Road;
- Develop strategies to deal with ballast water;
- Minimize new sources of nonpoint pollution;
- Reduce the discharge of (untreated) stormwater;
- Develop a management plan regarding non-native species; and
- Implement measures from the Northwest Ports Clean Air Strategy.

In addition, Pacific International Terminals will participate in monitoring, data collection, and research goals by providing relevant information.

Finally, implementation of key factors in the process of implementing the Aquatic Reserve Management Plan, as described in the Plan includes identifying coordination with community groups;

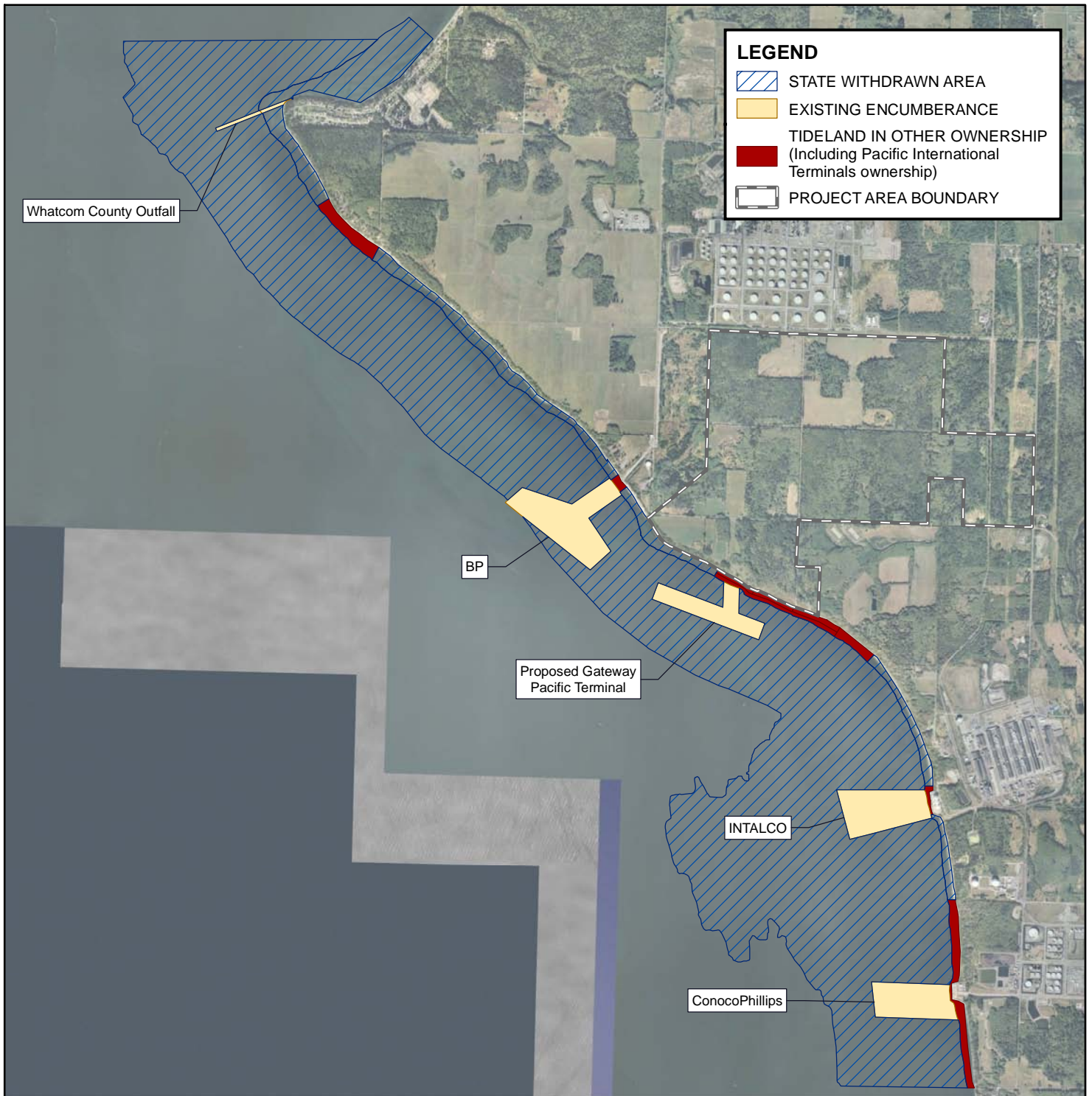

Source:  
 'State withdrawn area', 'Existing encumbrance' and 'Tideland in other ownership'  
 data obtained from Washington Department of Natural Resources on 11/03/2010:  
<http://fortress.wa.gov/dnr/app1/dataweb/dmmatrix.html>

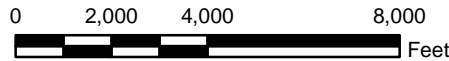

				CLIENT: <b>PACIFIC INTERNATIONAL          TERMINALS, INC.</b>	
PROJECT: <b>PROPOSED GATEWAY PACIFIC TERMINAL</b>		DWN BY: SD	DATUM: NAD83	DATE: FEBRUARY 2011	
TITLE: <b>CHERRY POINT AQUATIC RESERVE BOUNDARY</b>		CHK'D BY: KD	REV. NO.: 1	PROJECT NO.: 091515338C-18-01	
		PROJECTION: WA SP North, Ft.	SCALE: 1 inch=4,000 feet	FIGURE No.: <b>FIGURE 5-29</b>	



funding; and adaptive management. The Technical Advisory Committee (a subcommittee of the Cherry Point Workgroup) noted:

...while initially disturbing, industrial development associated with the piers appears to be compatible with aquatic reserve status and noted the opportunity to facilitate multiple-uses as an example where commercial activities and environmental resources can co-exist. (WDNR 2010, p. 8)

The proposed Terminal is consistent with and supports the Cherry Point Aquatic Reserve Management Plan by complying with and implementing the protection measures found therein.

### **Puget Sound Harbor Safety Plan**

The Puget Sound Harbor Safety Committee has established the Puget Sound Harbor Safety Plan (most recently revised in July 2009) as a guide to “good marine practices” specifically adapted for the Puget Sound region. The guide does not seek to supplant any existing regulations but instead complement and supplement federal, state, and local laws and regulations with guidelines that are non-regulatory in nature.

The Puget Sound Harbor Safety Plan supports and enhances safety and environmental stewardship in the region based on the experience of those familiar with the unique conditions of Puget Sound. The plan is targeted specifically to professional mariners transiting through navigable waters of the Puget Sound region and approaches from the sea. The US Coast Guard’s Captain of the Port, Ecology policies, and a traffic separation scheme approved by the International Maritime Organization govern these waters.

Recommendations found in the Puget Sound Harbor Safety Plan consist of using caution when relying on aids to navigation. Varying degrees of accuracy exist for aids to navigation, which preclude relying on any one aid when navigating. An *Advance Notice of Arrival* process asks for 96 hours of advance notice prior to arrival at a US port. The Coast Guard analyzes the *Advance Notice of Arrival* for safety and security purposes and may inspect the vessel if there are any concerns. This process may change in the near future as the Coast Guard is currently working on expanding the process. An Automatic Identification System is installed on certain categories of vessels and is used principally for identifying and locating vessels. Finally, the Plan directs vessels in appropriate reporting actions based on the type of emergency that has occurred.

The Puget Sound Harbor Safety Plan is applicable to the project because the *Advance Notice of Arrival* requirements apply to commercial vessels greater than 300 gross tons and all foreign vessels.

The Automatic Identification System is also applicable to the project based on the large ships that would access the Terminal.

The proposed Terminal is consistent with and supports the Puget Sound Harbor Safety Plan by complying with the policies therein.

#### **5.14.1.3 Whatcom County Countywide Planning Policies**

Countywide Planning Policies establish a countywide framework for developing and adopting county and city comprehensive plans. These comprehensive plans are the long-term policy documents used by each jurisdiction to plan for its future. They include strategies for land use, housing, capital facilities, utilities, transportation, economic development, and parks and recreation (RCW 36.70A.070). The role of the Countywide Planning Policies is to coordinate comprehensive plans of jurisdictions in the same county for regional issues or issues affecting common borders (RCW 36.70A.100).

As such, most of the policies in the Countywide Planning Policies have to do with future planning and interjurisdictional coordination. A few, however, have some bearing on the Gateway Pacific Terminal project.

- **Policy E.3:** Cherry Point shall be designated as an unincorporated industrial urban growth area in recognition of existing large-scale industrial land uses. Additional large-scale development shall be encouraged consistent with the ability to provide needed services and consistent with protecting critical areas along with other environmental protection considerations. The Cherry Point industrial area is an important and appropriate area for industry due to its access to deep-water shipping, rail, all-weather roads, its location near the Canadian border, and its contribution to the County's goal of providing family wage jobs.
- **Policy I.8:** Economic development should be encouraged that: a) does not adversely impact the environment; b) is consistent with community values stated in local comprehensive plans; c) encourages development that provides jobs to county residents d) addresses unemployment problems in the county and seeks innovative techniques to attract different industries for a more diversified economic base; e) promotes reinvestment in the local economy, and f) supports retention and expansion of existing businesses.
- **Policy I.11:** Whatcom County encourages siting of industrial uses in proximity to and to further utilization of our access to deep water and port facilities for shipping, rail, airports, roadways, utility corridors and the international border.

The proposed Terminal is consistent with and supports the Whatcom County Countywide Planning Policies, and complies with the pertinent policies therein.



### **5.14.2 Project Effects on Relationship to Plans and Policies**

The Terminal is consistent with export, job creation, and international goals found in the national and state export initiatives and effects on those plans and policies would be positive.

The proposed project is consistent with the Puget Sound Harbor Safety Plan. Since this is an advisory document, it would influence the operating procedures of the Terminal.

The Terminal is consistent with the Cherry Point Aquatic Reserve Management Plan. The project is identified specifically in the plan, and the location for the proposed Gateway Pacific Terminal wharf and trestle was not included within the Reserve footprint. Once required studies are undertaken and mitigation measures are implemented, the proposed project would comply with the management expectations stated in the Aquatic Reserve Management Plan.

The Washington State Transportation Plan identifies shortages of rail capacity as a limitation in providing the level of service necessary to meet expected growth within the state transportation network.

### **5.14.3 Proposed Design Features Intended to Reduce Impacts**

No design features to reduce impacts are proposed for impacts to plans and policies as no impacts are anticipated.

## **5.15 OTHER RESOURCE AREAS TO BE ADDRESSED AT A LATER DATE**

Several resource areas are currently undergoing further study, or a determination as to whether they will need further study, through the EIS process. These include:

- Noise,
- Energy,
- Aesthetics,
- Light and glare, and
- Commercial and recreational navigation.

These topics are discussed briefly below.

### 5.15.1 Noise

Noise has not been re-evaluated since the 1996 Draft EIS. A complete study of the affected environment, an impact analysis, and evaluation of design features to reduce impacts, if necessary, is anticipated for completion in April 2011.

An evaluation of noise effects in the Draft 1996 EIS included the following key findings:

- Construction would produce temporary increases in sound from roadway and rail line improvements. Receivers on surrounding properties may be able to hear noise from pile driving, excavation, and grading activities. Construction-related noise impacts would be unlikely at residential uses, as the nearest homes were approximately 1.5 miles from the project area. Operation-related noise impacts would occur from trucks at the Terminal, railroad traffic, ships, conveyors, and material loading and handling. These noise impacts would also be audible to surrounding industrial and agricultural users but not residences. Additional rail traffic on the rail main line would increase the frequency of train noise in the vicinity (Whatcom County 1996).
- Existing noise levels on the project site were not measured; however, a site visit identified that the site was relatively quiet with the loudest sounds from the marine waters, and no discernible noise from the adjacent industrial facilities (Whatcom County 1996).
- Construction noise could be minimized, if necessary, through the use of mufflers, engine intake silencers, engine enclosures, and turning off equipment when not in use, among other BMPs. No mitigation measures were proposed for operational noise from the project (Whatcom County 1996).
- The 1996 Draft EIS did not anticipate any significant noise impacts to occur.

### 5.15.2 Energy

Energy has not been evaluated for the proposed Terminal, nor was it addressed in the 1996 EIS. If energy is identified as an issue of concern during the upcoming EIS scoping process, then it will be addressed.

### 5.15.3 Aesthetics

Aesthetics has not been re-evaluated for the current proposed Terminal. The 1996 Draft EIS included a discussion of aesthetics, summarized as follows:

- Views from the project site include some of the San Juan Islands, Lummi Island, dock structures of Intalco, BP, and Tosco (now ConocoPhillips), and some of the associated upland development. The project area itself was visible from the surrounding industrial properties, and

possibly from the islands mentioned. Portions of the project area are also visible from the public access beach on Gulf Road, from Henry Road, and by passing watercraft. No residential users have views of the project area (Whatcom County 1996).

- The project would alter the visual character of the site from farmed land to industrial components. Storage buildings, covered conveyors, and rail access would characterize the industrial nature of the property. Marine structures, including the trestle and wharf and conveyor system, would require some portions of the bluff to be cleared and may provide some additional view of upland structures from the beach. However, existing vegetation may provide some screening of upland structures from the beach. The trestle, wharf, and ships accessing the wharf would be visible from the water to a distance of approximately 1 mile. Lighting on the trestle and wharf would make this also visible at night. Aesthetic values of the beach would be decreased due to the trestle and wharf structure dominating any views from the beach (Whatcom County 1996).

If aesthetics are identified as an issue of concern during the upcoming EIS scoping process, then this issue will be further addressed.

#### **5.15.4 Light and Glare**

Light and glare have not been re-evaluated for the current proposed Terminal. Key findings from the discussion of light and glare in the 1996 Draft EIS are summarized below:

- Existing sources of light and glare in the project area included industrial developments to the southeast and north of the project area and industrial rail traffic and road traffic. No existing sources of light or glare exist on the project site (Whatcom County 1996).
- The proposed project would generate light and glare from the trestle and wharf, upland facilities, and ships at berth. Lighting at the terminal would be most visible from the water and islands within visual range of the project area. The Terminal would operate day and night producing light at all times (Whatcom County 1996).
- Mitigation measures in the 1996 Gateway Pacific Terminal Final EIS included the use of directional shielding on lights where possible to lessen the light viewed from other locations; avoiding reflective surfaces on structures; preserving natural vegetation on the bank and immediately north of the beach to reduce impacts; and reintroducing cedar trees to provide screening (Whatcom County 1996).

If light and glare are identified as an issue of concern during the EIS scoping process, then it will be further addressed.

### **5.15.5 Commercial and Recreational Navigation**

An analysis of commercial and recreational navigation for the current proposed Terminal has not been completed yet. A complete evaluation of the existing commercial and recreational navigation environment of the subject and surrounding properties and potential environmental impacts will be addressed in the Vessel Traffic Analysis, scheduled for completion in mid-2011.

## CHAPTER 6 REFERENCES

- AMEC Earth & Environmental, Inc. (AMEC). 2008. Wetland Determination and Delineation, Gateway Pacific Terminal, Whatcom County, Washington. Prepared for Pacific International Terminals, Inc.
- . 2009. Stream and Bird Surveys Baseline Investigation, Gateway Pacific Terminal, Whatcom County, Washington. Prepared for Pacific International Terminals, Inc.
- . 2010. *Gateway Pacific Terminal Draft Archaeological Assessment Findings Report, Cherry Point Whatcom County, Washington*. AMEC Earth & Environmental, Bothell, WA. Report on file at the Department of Archaeology and Historic Preservation, Olympia, WA.
- . 2011. *Preliminary Conceptual Compensatory Mitigation Plan for the proposed Gateway Pacific Terminal, Whatcom County, Washington*. Prepared for Pacific International Terminals, Inc. February.
- . in preparation. *Draft Biological Assessment for the Gateway Pacific Terminal Project, Whatcom County, Washington*. To be Prepared for Pacific International Terminals, Inc.
- Anchor Environmental, LLC. 2001. Marine Resources of Whatcom County. Prepared for the Whatcom County Marine Resources Committee.
- Ausenco Sandwell. 2010a. Gateway Pacific Terminal Coal Study, Port Site Selection Overview. Prepared for Pacific International Terminals, Inc. April.
- Ausenco Sandwell. 2010b. Gateway Pacific Terminal Scoping Study Draft Report, Whatcom County, Washington. Prepared for Pacific International Terminals, Inc.
- Barboza, D. 2010. China Passes Japan as Second-Largest Economy. *The New York Times*, August 15 .
- Bayer, R.D. 1980. "Birds feeding on herring eggs at the Yaquina Estuary, Oregon." *Condor* 82:193-198.
- Ben C. Gerwick, Inc. 1993. *ARCO D.C. Project, Pile Driveability*, Correspondence.
- Bird, E.C.F. 1994. Chapter 2. "Physical setting and geomorphology of coastal lagoons." Pages 9-40 in B. Kjerfve, editor. *Coastal lagoon processes*. Elsevier, Amsterdam, The Netherlands.

- Blodgett, M.E. 1976. *Cherry Point: a Strait of Georgia Fishing Station*. M.A. Thesis, Department of Anthropology, Western Washington University, Bellingham, Washington.
- Buckley, R., and G. Hueckel. 1985. Biological processes and ecological development on an artificial reef in Puget Sound, Washington. *Bulletin of Marine Science* 37:50-69.
- Calambokidis, J., G.H. Steiger, D.K. Ellifrit, B.L. Troutman, and C.E. Bowlby. 2004. "Distribution and abundance of humpback whales (*Megaptera novaeangliae*) and other marine mammals off the northern Washington Coast." *Fisheries Bulletin* 102:563-580.
- Chavez F.P., J. Ryan, S.E. Lluch-Cota, C. Niquen. 2003. From anchovies to sardines and back: multidecadal change in the Pacific Ocean. *Science*, 299: 217-221.
- City of Ferndale Comprehensive Plan. 2007. 2005 Update to the 1996 Plan. Ferndale, Washington.
- Council on Environmental Quality (CEQ). 1997. Environmental Justice, Guidance Under the National Environmental Policy Act. December. <http://www.epa.gov/>.
- Cowardin et al. 1979. Classification of Wetlands and Deepwater Habitats of the United States. FWS/OBS-70/31. 131 pp. U.S. Fish and Wildlife Service, Office of Biological Services, Washington, D.C.
- Desilets, M. 1995. Lithic Reduction Strategies and the Bipolar Technique at Cherry Point (45WH1). Unpublished M.A. thesis, Western Washington University, Bellingham.
- Donald, J. 1995. A Technical and Functional Examination of the Slate Industry at the Cherry Point Site (45WH1). Unpublished M.A. thesis, Western Washington University, Bellingham.
- Dugas, A.E. 1996. Metapodial reduction: a case study from a Northwest Coast shell midden. Unpublished M.A. thesis, Western Washington University, Bellingham.
- ENSR Consulting and Engineering (ENSR). 1995. Assessment of Marbled Murrelets and Other Marine Bird Use near the ARCO Marine Terminal. Report prepared for ARCO Products Company Cherry Point Refinery.
- Environment Canada. 1998. Sustaining marine resources: Pacific herring fish stocks. State of the Environment (SOE) Bulletin No. 98-2.
- ESA Adolfson. 2007. Birch Bay Watershed Characterization And Watershed Panning Pilot Study Prepared by ESA Adolfson in association with the Washington Department of Ecology,

- Department of Fish and Wildlife, Puget Sound Partnership and Environmental Protection Agency. Prepared for Whatcom County Planning and Development Services.
- EVS (EVS Environment Consultants, Inc.). 1999. "Cherry Point screening level ecological risk assessment." Prepared for Washington State Dept. of Natural Resources Aquatic Resources Division. EVS Environment Consultants, Inc. EVS Project No. 2/868-01.1. (Available from Golder Environmental 2200 6th Ave, Seattle, WA 98121).
- Fairbanks Environmental Services, Inc. (Fairbanks). 2005. *Whatcom County Submerged Aquatic Vegetation Survey, Final Report*. Prepared for Whatcom County Public Works and Water Resources Division and Whatcom County Marine Resources Committee.
- Falcone, E., J. Calambokidis, G.H. Steiger, M. Malleson, and J. Ford. 2005. "Humpback whales in the Puget Sound/Georgia Strait Region." *Proceedings of the 2005 Puget Sound Georgia Basin Research Conference*, 4 pp.
- Federal Register. 2008. Compensatory Mitigation for Losses of Aquatic Resources; Final Rule. Vol. 73, No. 70. p. 19594, U.S. Government Printing Office, Washington, D.C.
- Ford, J.K.B., G.M. Ellis, and K.C. Balcomb. 2000. *Killer whales: the natural history and genealogy of Orcinus orca in British Columbia and Washington State*. 2nd ed. University of British Columbia Press. Vancouver, British Columbia.
- Gaeckle, J. 2009. Eelgrass (*Zostera marina* L.) Abundance and Depth Distribution at two environmental aquatic reserves. Final Report to the DNR Aquatic Reserves Program.
- Gardner, G.A. 1977. "Analysis of zooplankton population fluctuations in the Strait of Georgia, British Columbia". *J. Fish. Res. Board Can.* 34: 1196-1206.
- GeoEngineers, Inc. 1997. *Preliminary Geotechnical Characterization, Gateway Pacific Terminal Project, Cherry Point Industrial Area, Whatcom County, Washington*. June.
- GeoEngineers, Inc. 2010. *Onshore Geotechnical Program Phase I, Factual Data Report, Proposed Gateway Pacific Terminal, Whatcom County, Washington*. June.
- Grabert, G.F. and M. Hall. 1978. *An Archaeological Reconnaissance at Cherry Point, Washington*. Reports in Archaeology, No. 7. Department of Anthropology, Western Washington University, Bellingham.
- Grette, G.B. 1985. Fish monitoring during pile driving at Hiram H. Chittenden Locks, August-September 1985. Seattle District Army Corps of Engineers. Evans-Hamilton, Inc.

- Griswold, D. 2007. *The competition for world resources: China's demand for commodities*. Retrieved from Cato Institute, Washington, D.C.: [www.cato.org](http://www.cato.org).
- Gustafson R.G., J. Drake, M.J. Ford, J.M. Myers, E.E. Holmes, and R.S. Waples. 2006. Status review of Cherry Point Pacific herring (*Clupea pallasii*) and updated status review of the Georgia Basin Pacific herring distinct population segment under the Endangered Species Act. U.S. Dept. Commerce. NOAA Tech. Memo. NMFS-NWFSC-76, 182 pp.
- Haegle, C.W. 1993. Epibenthic invertebrate predation of Pacific herring, *Clupea pallasii*, spawn in British Columbia. *Can. Field Nat.* 107:83–9.
- Hallock, L.A. and McAllister, K.R. 2009. Western Terrestrial Garter Snake. Washington Herp Atlas. <http://ww1.dnr.wa.gov/nhp/refdesk/herp/>
- Hay, D. E., P.B. McCarter, and K.S. Daniel. 2001. Tagging of Pacific herring *Clupea pallasii* from 1936–1992: A review with comments on homing, geographic fidelity, and straying. *Can. J. Fish. Aquat. Sci.* 58:356–1370.
- Healey, M.C. 1998. Life History of Chinook Salmon (*Oncorhynchus tshawytscha*). In C. Groot and L. Margolis, editors. *Pacific salmon life histories*. University of British Columbia Press. Vancouver, British Columbia.
- Heck, Jr., K.L., and T.A. Thoman. 1984. The nursery role of seagrass meadows in the upper and lower reaches of Chesapeake Bay. *Estuaries* 7:70-92.
- Hoffman, Larry. January 20, 2011. Assistant Fire Chief Larry Hoffman (Fire District No. 7) personal communication with Tiffany Quarles (AMEC) regarding the fire district's capacity to accommodate the Terminal.
- Hruby, T. 2004. Washington State wetland rating system for Western Washington—Revised. #04-06-025. Olympia, Washington: Washington Department of Ecology.
- IHS Global Insight. 2009. *Evaluation of Maritime Policy in Meeting the Commercial and Security Needs of the United States*. U.S. Department of Transportation, Maritime Administration. January 7.
- Institute of Transportation Engineers (ITE), 2008, *Trip Generation*. 8<sup>th</sup> Edition.
- International Monetary Fund. 2010. *Regional economic outlook: Asia and Pacific: consolidating the recovery and building sustainable growth*. Washington, D.C.: International Monetary Fund.



- Jeffries, S. J., R. F. Brown, H. R. Huber, and R. L. DeLong. 1996. Pages 83–94 in P. S. Hill and D. P. DeMaster, editors. *Assessment of harbor seals in Washington and Oregon, 1996*. MMPA and ESA Implementation Program. AFSC Processed Report 97-10.
- Kahler, T. July 13, 2000. A summary of effects of bulkheads, piers, and other artificial structures and shorezone development on ESA-listed salmonids in lakes. City of Bellevue prepared by The Watershed Company and Washington Cooperative Fish and Wildlife Research Unit, University of Washington. Seattle, Washington.
- Kegel, B.L. 1998. Last modified November 6, 1998. Species Descriptions. The Bivalves of The Evergreen State College, Olympia, WA. Evergreen State College.  
<http://academic.evergreen.edu/t/thuesene/bivalves/Specieslist.htm>
- Kjerfve, B., editor. 1994. *Coastal lagoon processes*. Elsevier, Amsterdam, The Netherlands.
- KJS Associates, Inc., 1996, *Gateway Pacific Terminal Transportation Impact Study*.
- Kyte, M.A. 1999. Memorandum: Observations on a qualitative examination of the intertidal zone of the Cherry Point shoreline, 14 and 15 June 1999. Berger/Abam Engineers, Inc., Federal Way, WA.
- Kyte, M.A. 2000. Memorandum report: Observations on a qualitative examination of the intertidal zone of the Cherry Point shoreline. Submitted to ARCO Cherry Point Refinery, Alcoa Intalco Works, and Tosca Ferndale Refinery by Berger/Abam Engineers, Inc., Federal Way, WA.
- Kyte, M.A. 2001. Observations on a qualitative examination of the intertidal zone of the Cherry Point reach June 22–24, 2001. Prepared for BP Cherry Point Refinery, Intalco Aluminum Corporation, and Tosca Ferndale Refinery by Golder Associates Inc., Redmond, WA.
- Kyte, M.A. 2002. A qualitative examination of the intertidal zone of the Cherry Point reach June 24 and 25, 2002. Prepared for BP Cherry Point Refinery, Blaine, Washington and Phillips 66 Ferndale Refinery, Ferndale, Washington by Golder Associates Inc., Redmond, WA.
- Kyte, M.A. 2003. Report on a qualitative examination of the intertidal zone of the Cherry Point reach June 14 and 15, 2003. Prepared for Conoco Phillips Ferndale Refinery, Ferndale, Washington by Golder Associates Inc., Redmond, WA.
- Kyte, M.A. 2004. A qualitative examination of the intertidal zone of the Cherry Point reach, 2004. Entrix, Inc., Seattle, WA.

- Laufle, C.F., and Pauley, G.B. 1985. *Fish colonization and materials comparisons on a Puget Sound artificial reef*. *Bulletin of Marine Science* 37, 227-234.
- Leonard, W.P., H.A. Brown, L.L.C. Jones, K.R. McAllister, and R.M. Storm. 1993. *Amphibians of Washington and Oregon*. Seattle Audubon Society. Seattle, WA. 168pp.
- Leow, C., and R. Salamat. 2010. Commodities demand in Asia surging on infrastructure boom, London Metal Exchange Chief Says. *Bloomberg*, July 9.
- Levings C.D. 1983. Some observations of juvenile herring at the Fraser River Estuary, B.C. Proceedings of the fourth Pacific coast herring workshop, October 7-8, 1981. Canadian Manuscript Report of Fisheries and Aquatic Sciences, No. 1700: 91-102.
- Love, M.S. 2006. Potential use of offshore marine structures in rebuilding an overfished rockfish species, bocaccio (*Sebastes paucispinis*). *Fishery Bulletin of the Fish and Wildlife Service* 104(3), 383-390.
- Lummi Natural Resources Department, 2008. Lummi Nation Atlas. February.
- Lymon C. Reese and Associates. 1993. *Interim Report, Design of Pile Foundations ARCO Dock Completion Project, Cherry Point Refinery, Cherry Point, Washington*.
- Markham, V. 1993. *An Historic EuroAmerican Fishtrap Camp at Cherry Point (45WH1)*. Unpublished M.A. thesis, Western Washington University, Bellingham, Washington.
- Martin Associates. 2011. *The Projected Economic Impacts of the Development of a Dry Bulk Commodity Terminal at Cherry Point*. February 16, 2011.
- Miller, B., C. Simenstad, J. Cross, K. Fresh, and N. Steinfort, 1980. *Nearshore Fish and Macroinvertebrate Assemblages along the Strait of Juan de Fuca Including the Food Habits of the Common Nearshore Fish*. NOAA-EPA-06-E693-EN and FRI-UW-8801.
- Miss, C.J. 1996. *Preliminary Cultural Resources Assessment of the Proposed Gateway Terminal at Cherry Point, Whatcom County, Washington*. NWAA Report 96-6. Northwest Archaeological Associates, Inc., Seattle.
- Mumford, T. Jr. 2007. *Kelp and eelgrass in Puget Sound*. Puget Sound Nearshore Partnership Technical Report 2007-05. Olympia, WA.
- Meyer Resources, Inc, 2004. *A Guide for Analysis of Project Impacts on the Lummi Nation*. Final Report to the Lummi Nation.

- National Marine Fisheries Service (NMFS). 2007. Endangered Species Act Section 7 Informal Consultation and Magnuson-Stevens Fishery Conservation and Management Act Essential Fish Habitat Consultation for the Port of Seattle Terminal 30 Reactivation and Terminal 91 Cruise Ship Relocation, Elliot Bay, (King County, Washington) Puget Sound HUC 17110019 and Lower Green River HUC 171100130399, COE No.: 200601091.
- NMFS. 2006. Endangered and threatened species; designation of critical habitat for Southern Resident killer whales. Federal Register [Docket No. 060228057-6283-02, 29 November 2006] 71(229):69054-69070.
- Nightingale, B. and C. Simenstad. 2001. Overwater Structures: Marine Issues. Submitted to Washington Department of Fish and Wildlife, Washington Department of Ecology, and Washington Department of Transportation.
- Nixon, S. W. 1995. Coastal marine eutrophication: a definition, social causes, and future concerns. *Ophelia* 41:199-219.
- Nussbaum, R.A., E.D. Brodie, Jr., and R.M. Storm. 1983. Amphibians and Reptiles of the Pacific Northwest. University Press of Idaho, Moscow, Idaho. 332 pp.
- Nysewander, David R. et al. 2005. Report of marine bird and marine mammal component: Puget Sound Ambient Monitoring Program, for July 1992 to December 1999 period. Available from Wildlife Management Program, Washington Department of Fish and Wildlife, Olympia, WA. 194 pp.
- O'Clair, R.M., and C.E. O'Clair, 1998. *Southeast Alaska's Rocky Shores*. Plant Press, AK. 561 pp. Black and white illustrations. ISBN 0-9664245-0-6.
- Office of the Governor. 2010. *Governor Gregoire announces new state export initiative*. Retrieved from Office of the Governor: [www.governor.wa.gov/news/news-view.asp?pressrelease=1517&newstype=1](http://www.governor.wa.gov/news/news-view.asp?pressrelease=1517&newstype=1). June 22.
- Office of the President. 2010. *National Export Initiative*. Executive Order. Retrieved from Office of the President, <http://www.whitehouse.gov/the-press-office/executive-order-national-export-initiative>. March 11.
- Ota, Ken., 2006. Herring Biologist, California Dept. Fish and Game. Personal communication with Mark Pedersen, AMEC Earth & Environmental. November 19.
- O'Toole, Mark. 2008. Personal communication with Mark Pedersen (Margenex) regarding comments on the Gateway Pacific Terminal Herring Monitoring Program Objectives. March 12.

- O'Toole, Mark. 2010. Personal communication with Mark Pedersen (Margenex) regarding the effects of vessel traffic on herring at Cherry Point. December 20.
- Parametrix and Adolfson Associates. 2005. Whatcom County Critical Areas Ordinance: Best Available Science Review and Recommendations for Code Update. Prepared for Whatcom County Planning and Development Services.
- Park, W., D.C. Douglas, and T.C. Shirley. 2007. North to Alaska: Evidence for conveyor belt transport of Dungeness crab larvae along the west coast of the United States and Canada. *Limnology and Oceanography* 52(1):248-256
- Park, C. and F. Zhai. 2004. *Asia's Imprint on Global Commodity Markets*. ERD Working Paper No. 90. Asian Development Bank, Economics and Research Department. Retrieved from [http://www.adb.org/Documents/ERD/Working\\_Papers/WP090.pdf](http://www.adb.org/Documents/ERD/Working_Papers/WP090.pdf)
- Puget Sound Harbor Safety Committee. 2009. "Puget Sound Harbor Safety Plan". Revised July 2009.
- Ratté, L.D. and E.O. Salo. 1985. *Under-pier ecology of juvenile pacific salmon (Oncorhynchus spp.) in Commencement Bay, Washington*. Port of Tacoma. M.S. Thesis, University of Washington. Seattle, Washington.
- Resource Analysts International. 2006. Letter from Vidar Wespestad (Resource Analysts International) to Mark Pedersen (AMEC Earth and Environmental) re: data analysis for hydroacoustic surveys for herring.
- Rorabaugh, A.N. 2009. Barbed bone and antler technologies: cultural transmission and variation in the Gulf of Georgia, Northwest North America. Unpublished M.A. thesis, Western Washington University, Bellingham, Washington.
- Schweigert, J. et al. 2001. Stock assessment for British Columbia herring in 2001 and forecasts of potential catch in 2002. DFO Canadian Science Advisory Secretariat, Research Document 2001/140, Fisheries and Oceans Canada.
- Settlement Agreement. 1999. Settlement Agreement between Pacific International Terminals; Whatcom County; the State of Washington Departments of Ecology and Fish and Wildlife; and North Cascade Audubon Society, People for Puget Sound, League of Women Voters of Bellingham, Ocean Advocates, and Washington Environmental Council. July 1, 1999.
- Shannon & Wilson, Inc. 1993. *Geotechnical Data Report, ARCO Dock Completion Project, Cherry Point, Washington*. December.

- Shapiro and Associates. 1996. Gateway Pacific Terminal Draft Environmental Impact Statement. Prepared for Pacific International Terminals.
- Shaw. 1986. Species Profiles: Life histories and environmental requirements of coastal fishes and invertebrates. US Fish and Wildlife Service Biological Report 82 (11.46).
- Smith, S.E. and D.H. Shull. 2009. Survey of Whatcom County, Washington Nearshore Rockfish by Remotely Operated Vehicle and Implications for Marine Protected Areas. Prepared for the Whatcom County Marine Resources Commission and the Northwest Straits Commission. Huxley College of the Environment, Western Washington University.
- Somero, G.N. 2002. Thermal physiology and vertical zonation of intertidal animals: optima, limits, and cost of living. *Integrative and Comparative Biology* 42:780-789.
- Stick, K. and A. Lindquist. 2009. 2008 Washington State Herring Stock Status Report. Washington Department of Fish and Wildlife FPA 09-05.
- Stone, C.J. and M.L. Tasker. 2006. The effects of seismic airguns on cetaceans in UK waters. *Journal of Cetacean Research and Management*. 8(3):255-263.
- Stout, H.A., R.G. Gustafson, W.H. Lenarz, B.B. McCain, D.M. Van Doornik, T.L. Builder, and R.D. Methot. 2001. Status review of Pacific herring in Puget Sound, Washington. U.S. Dept. Commer., NOAA Tech Memo. NMFS-NWFSC-45.
- Taylor, F.H.C. 1955. The Pacific herring (*Clupea pallasii*) along the Pacific coast of Canada. *Int. N. Pac. Fish Comm. Bull.* 1:105–128.
- Thom, R.M. 1981. Composition, habitats, seasonal changes and productivity of macroalgae in Grays Harbor Estuary, Washington. *Estuaries* 7:51-60.
- Thomas, A., M. Lance, S. Jeffries, A. Acevedo-Gutierrez. 2009. Selective foraging by harbor seals: The importance of herring spawning and holding aggregations. Poster presented at the Annual Meeting for the Society of Marine Mammalogy, Quebec, Canada.
- Transportation Research Board. 2000. *Highway Capacity Manual*.
- Trumble, R.J., R.E. Thorn, and N.A. Lemberg. 1982. The Strait of Georgia herring fishery: a case history of timely management aided by hydroacoustic surveys. *Fish. Bull.* 80(2), pp. 381-388.
- U.S. Army Corps of Engineers (USACE). 2008. *Deepwater Ports & Harbors: Value to the Nation*. Retrieved from [www.spn.usace.mil/value\\_to\\_the\\_nation/deepwaterports.pdf](http://www.spn.usace.mil/value_to_the_nation/deepwaterports.pdf). Brochure

US Census Bureau. 2010a. State & County Quickfacts.

<http://www.factfinder.census.gov/home/saff/main.html? lang=en>.

———. 2010b. 2005 – 2009 American Community Survey 5-Year Estimates. Available on-line at

<http://www.factfinder.census.gov/home/saff/main.html? lang=en>.

———. 2010c. 2009 Poverty thresholds by Size of Family and Number of Children. Available on-line

at <http://www.census.gov/hhes/www/poverty/data/threshld/index.html>.

US Department of Commerce. 2010. Country-Specific Tariff and Tax Information. Available on-line at

[http://www.export.gov/logistics/eg\\_main\\_018142.asp#P664\\_28229](http://www.export.gov/logistics/eg_main_018142.asp#P664_28229)

US Environmental Protection Agency (EPA). 1995. *Compilation of Air Pollutant Emission Factors, Volume 1: Stationary Point and Area Sources*. AP 42, Fifth Edition. Office of Air Quality Planning and Standards, Office of Air and Radiation. Research Triangle Park, NC. January.

US Fish and Wildlife Service (USFWS). 2004. Draft Recovery Plan for the Coastal-Puget Sound Distinct Population Segment of Bull Trout (*Salvelinus confluentus*). Volume I (of II): Puget Sound Management Unit. Portland, Oregon. 389 + xvii pp.

US International Trade Commission, 2010. Harmonized Tariff Schedule of the United States.

Available on-line at <http://hts.usitc.gov/>

US Maritime Administration. 2009a. "America's Ports and Intermodal Transportation System."

US Maritime Administration. 2009b. *U.S. Water Transportation Statistical Snapshot*. US Department of Transportation, Maritime Administration, Office of Policy & Plans. Washington, D.C.: USDOT Maritime Administration.

U.S. Maritime Administration. 2009c. *Vessel Calls Snapshot*. U.S. Department of Transportation, Maritime Administration, August.

VanBuskirk, S. 2000. The origin of tan ashy lenses in a Puget Sound shell midden; results of sediment analysis. Unpublished M.A. thesis, Western Washington University, Bellingham, Washington.

Washington Department of Fish and Wildlife (WDFW). 2010. Washington State Ballast Water Program: Overview. <http://wdfw.wa.gov/fish/ballast/ballast.htm>. Accessed July 14, 2010.

———. 2006. Whatcom Wildlife Area Management Plan. Wildlife Management Program, Washington Department of Fish and Wildlife, Olympia. 86 pp.

———. 2005. Habitats and Species Map. Produced July 28, 2005.

Washington Department of Natural Resources (WDNR). 2010. Cherry Point Environmental Aquatic Reserve Management Plan. November.

Washington Department of Revenue. 2010. Northwest Economic Council, Whatcom County Publication, Whatcom County Tax Proceeds & Distribution.

———. 2010b. Northwest Economic Council, Whatcom County Publication, Whatcom County Tax Proceeds & Distribution.

Washington State Department of Transportation (WSDOT). 2010. Biological Assessment Preparation for Transportation Projects: Advanced Training Manual.

Washington State Employment Security Department, 2010a. Labor Market and Economic Analysis Branch. Available on-line at <http://www.workforceexplorer.com/>.

———. 2010b. Resident Labor Force and Employment in Washington State and Labor Market Areas. December. Available on-line at <http://www.workforceexplorer.com/>.

Washington State University (WSU) Beach Watchers. Last updated October 2007. Accessed February, 2011. EZ-ID Guides.  
<http://www.beachwatchers.wsu.edu/ezidweb/animals/index.php>

Westmar Consultants, Inc. (Westmar). 1996. Beach Processes at Cherry Point, Washington State. Appendix C to the Gateway Pacific Terminal Draft Environmental Impact Statement.

Whatcom County. 1996. Planning and Development Services. Gateway Pacific Terminal Draft Environmental Impact Statement.

———. 1997. Planning and Development Services. Gateway Pacific Terminal Final Environmental Impact Statement. February.

———. 2006. Shoreline Master Program Update: Shoreline Inventory and Characterization, Part 1 (Chapters 1 – 3). Prepared by Parametrix, Bellevue, WA, and Adolfson Associates, Inc., Seattle. June.

———. 2007. Point Whitehorn Marine Reserve, County Parks. Available online at <http://www.co.whatcom.wa.us/parks/pointwhitehornmarinereserve.jsp>.

- . 2010. *Comprehensive Plan*. Bellingham, WA: Whatcom County. [http://www.co.whatcom.wa.us/pds/planning/comp\\_plan/comp\\_plan.jsp](http://www.co.whatcom.wa.us/pds/planning/comp_plan/comp_plan.jsp).
- Whatcom County Marine Resources Committee (MRC). 2001. The marine resources of Whatcom County. Prepared by Anchor Environmental LLC for Whatcom County MRC. April 2001. Available online
- Whatcom County Parks and Recreation Department. 2009. 2009-2010 Final Budget. Whatcom County, Washington.
- Whatcom Transportation Authority, Route Maps, <http://www.ridewta.com>.
- Williams, G.D., R.M. Thom, M.C. Miller, D.L. Woodruff, N.R. Evans, and P.N. Best. 2003. Bainbridge Island Nearshore Assessment: Summary of Best Available Science. PNWD-3233. Prepared for the City of Bainbridge Island: Bainbridge Island, WA; by Battelle Marine Sciences Laboratory: Sequim, WA.
- Wilson, B., and L.M. Dill. 2002. Pacific herring respond to simulated odontocete echolocation sounds. *Can. J. Fish. Aquat. Sci.* 59:542–553.
- Wilson, B., R.S. Batty, and L.M. Dill. 2003. Pacific and Atlantic herring produce pulse sounds. *Biol. Letters* 271:S95–S97.